

# OSHIMA<sup>®</sup>

欢迎使用“欧西玛”迷你式粘合机

THANK YOU FOR USING "OSHIMA" MINI COMPACT PRESS MACHINE

使用前，请详阅

BEFORE YOU BEGIN, PLEASE READ CAREFULLY

OP-450GS

OP-520GS

使用说明书

OPERATING MANUAL

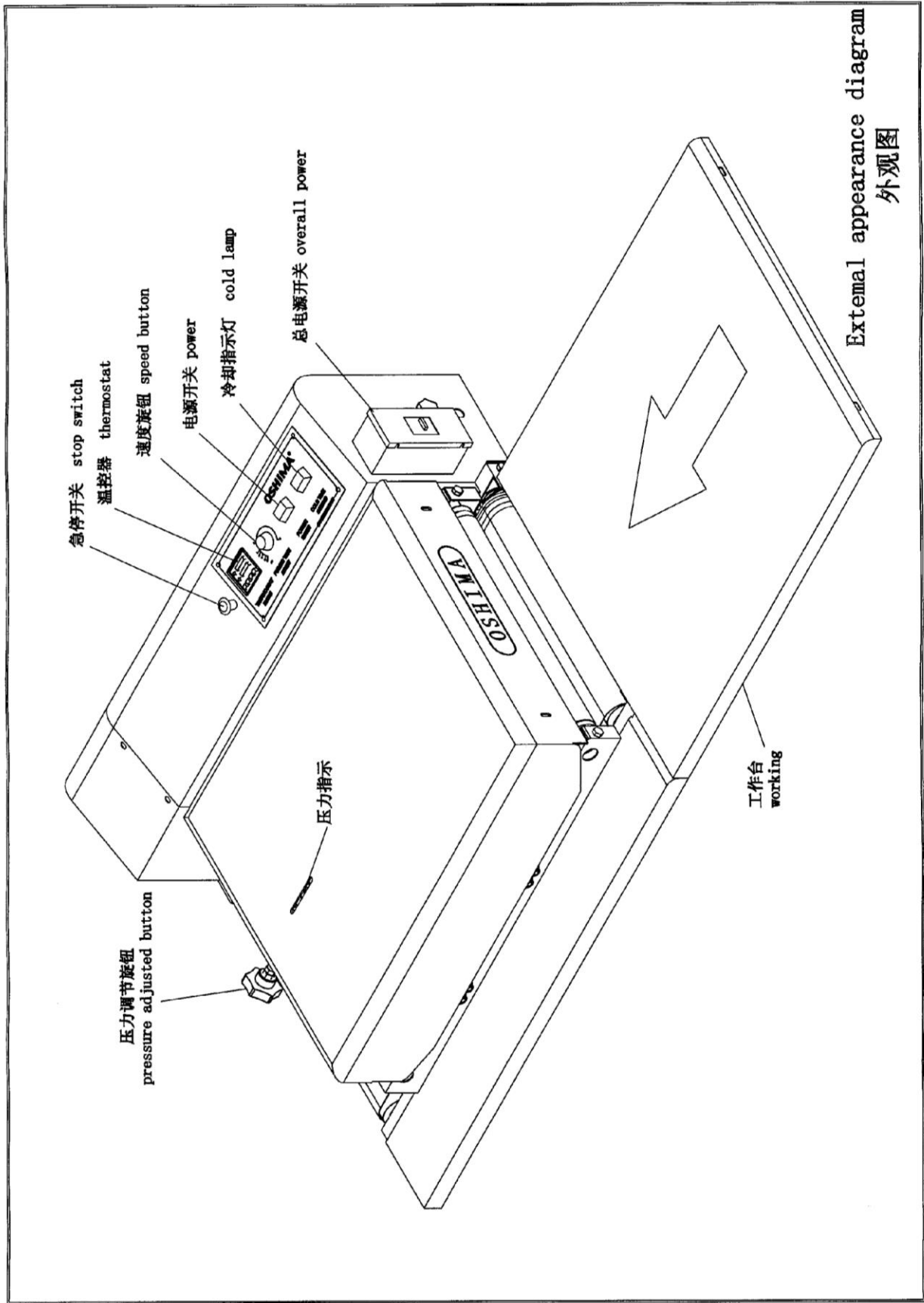

# 操作面板

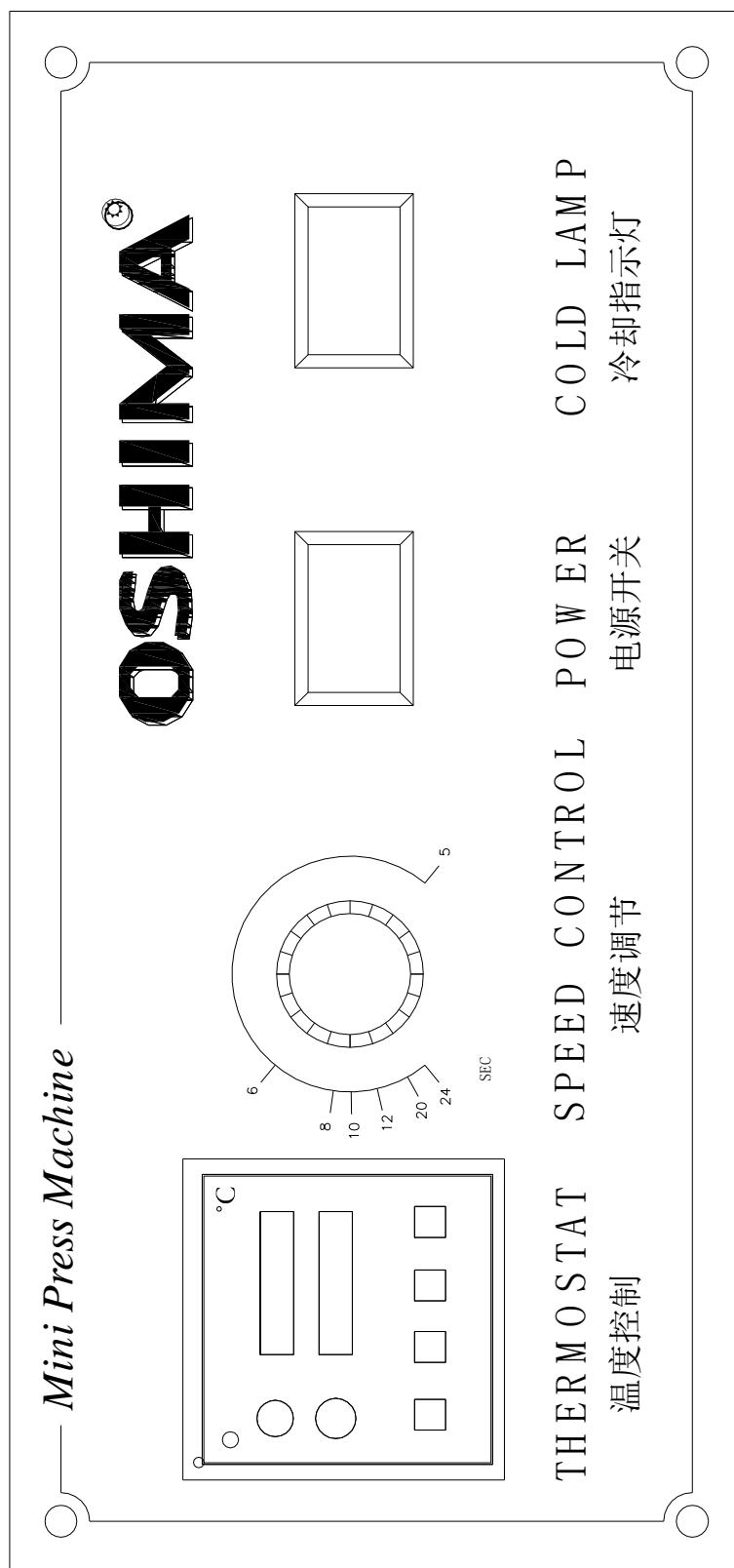

## 一、開機

- 1、 接上使用電源，(請特別注意；1P220V 電源線採用三線，即紅接火線，黑接零線，黃接地。切勿接錯。)將機器總電源開關撥向“ON”位置。
- 2、 按下電源開關。調整使用速度(壓著時間以 10-34 秒之間為正常使用)，設定溫度以及壓力(速度、溫度、壓力之調整視燙件之布的特性而定)；本機最高使用溫度 180°C。
- 3、 冷卻時按電源開關，該重定機器會自動運行，當皮帶溫度冷卻到 60°C 以下，機器自動停機。

## 二、溫度檢修部分

- A 不加溫：
- 1、 檢視電源開關有無打開；
  - 2、 檢視溫度控制器有無設定；
  - 3、 溫度控制器不動作，更換“溫度控制器”；
  - 4、 保護器跳脫或內部短路；
  - 5、 “溫度感應線”(SENER)成開路狀態；
- B 加溫過高：
- 1、 溫度控制器輸出無法斷開，造成 SSR 加熱；
  - 2、 SSR 固態繼電器觸點短路，更換 SSR。

## 三、皮帶運轉檢修部分

### A 運轉指示燈有動作：

- 1、 馬達控制器故障(包括皮帶全速運轉無法控制)；
- 2、 馬達或傳動部分卡死；
- 3、 皮帶表面有粘膠，使上下皮帶粘合，因而馬達無法轉動皮帶請先將溫度開關打開，將溫度設定在 120°C；當溫度到 120°C 時，請開啟馬達使皮帶轉動後，清潔皮帶表面；

### B 運轉指示燈無動作

- 1、 檢視電源有無輸入；
- 2、 皮帶偏離，依照“皮帶偏離調整說明”調整：

3、 檢視控制之保險絲有無斷毀。

C 皮帶調整說明

①450GB028 皮帶張力滾筒

②450GB029 下傳動滾筒

③450GA002 滾筒座

④450GB026 波浪滾筒

⑤450GB027 矽膠滾筒

注意：

- 1、 當更換皮帶時，請確認④、⑤長的一邊靠邊皮帶黃色繩邊位置。

矽膠滾筒



长

短

- 2、 在皮帶安裝好時，保證皮帶黃色在①、②靠近滾筒邊緣的位置一樣寬（約1-2MM）

黃色線

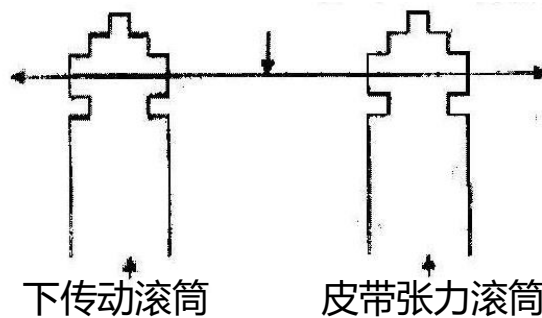

下传动滚筒

皮带张力滚筒

- 3、 如果寬度不同，請調整③左右移動然後確認黃色邊緣一樣寬。如注示（2）（上面箭頭只代表參考值）

附：如果皮帶繩邊嚴重磨損，則無法調整。

#### 四、注意事項

1. 工作臺面，請勿放置硬物（如：剪刀、筆、固定針……），以防止隨著邊件捲入機器內，而造成皮帶損壞及斷裂；
2. 出料口，上下撥片/刮片、皮帶接觸之面，若附有髒物，必須隨時清除，以保持皮帶表面之清潔；
3. 不能在皮帶的內裏作清潔，只能清潔皮帶表面；每日下班前應用壓縮空氣槍徹底清潔機台內部。
4. 如有粘膠或附著其他髒物，也須隨時以“清潔劑”清除。
5. 務必用隨機附送到水平儀將機器調整水準後再開機運行。
6. 當遇到較厚布料時，請適當減輕或放掉壓力，以防皮帶卡死。
7. 機器溫控器各內部參數，出廠前已設定好，切務隨意調節，否則會影響機器的正常運行。用戶只需設定所需的溫度即可。
8. 請不定期給面器各傳動部份加注潤滑油（高溫黃油）。  
請根據工用時間反工作量，適時更換清潔布。（清潔布請使用純棉布，一般包裹 3-4 層為宜，不可太厚。）
9. 本機器屬開邊式粘合機，最大使用寬度不得超過 450MM（OP-450）或 520MM（OP-520）或只需單邊粘合之大片襯布。
10. 如果貴公司要使用開邊式工作，請把上機架與下機架的連接固定板拆卸下來。
11. 具體操作前，請詳閱使用說明書。

## 一、Switch On

1. Connect to the power,( please notice the power specification 1P/220V or 3P/220V. Please do not connect wrongly.)
2. Switch the power switch on. Adjust the speed( time setting in the range of 10-34 seconds as the normal using), then set up temperature and top pressures;( the adjustment of the speed, temperature, pressure depend on the characteristics of fabrics. the maximum service temperature of 180°C
3. Switch the power button to Off status. The machine will be cooled down automatically. When belt temperature lower below 60°C, the machine will stop automatically.

## 二、Temperature Trouble Shooting

A、Temperature doesn't work:

- 1、Exam the power switch whether turn on.
- 2、Does the thermostat be set?
- 3、Replace the thermostat if did not work.
- 4、Protective jumps whether off or inner electric part short circuit;
- 5、The temperature probe responds the line"( SENSER) been non-working.

B、Temperature is overheated.

- 1、The temperature controller can't control, resulting in the SSR keeps heating.
2. The SSR gets short circuit, Please replace the SSR.

### 三、 Belt Transmission Trouble Shooting

A、 Working Indicator light is on:

- 1、 Motor controller was break-down, or belts keep on full speed, can not be controlled.
- 2、 Motor or transmission system was stuck.
- 3、 There are some glue adhered to the belt surface causing belts stuck. Please turn thermostat and set. the temperature at 120°C. When reach to 120°C, turn on the motor and then clean the belt surface.

B、 Indicator lamp is off:

- 1、 Does the power switch turn to “ON” position?
- 2、 Do the belts go warping? Please adjust the belts accordingly.
- 3、 Whether the fuse of controller is breakdown.

C、 ADJUSTMENT FOR BELT

- ①450GB028 Belt Tension Roller
- ②450GB029 Lower driving Roller
- ③450GA002 Roller Set
- ④450GB026 Wave Roller
- ⑤450GB027 Silicon Roller

Attention:

- 1、 When replace belt, please confirm④、 ⑤longer side close to belt yellow linear guide edge.

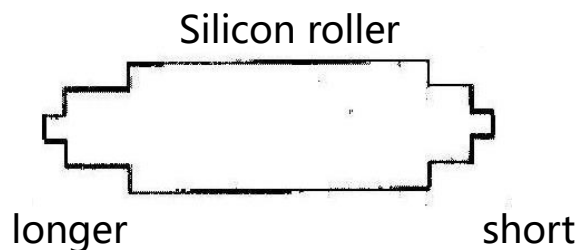



- 2、 Once belt mounted, pls confirm the width of the yellow linear guide edge is the same (about 1-2mm) between ①、 ② .

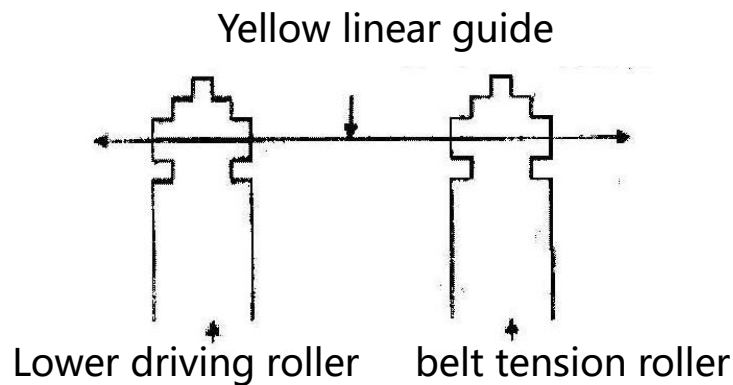

- 3、 If the width is different, please adjust ③ towards right & left to align the yellow linear guide edge with the same width as point (2) (The arrow headed on machine is for reference)

P.S. If the yellow guide linear edge is worn seriously, it could not be adjusted. Please replace a new belt.

#### **四、 Attentions**

- 1、 Do not put any hard objects (such as scissors, ball pen, needle.....) to the entrance of the belt.
- 2、 Please keep the exit, the strip off device / scraper clean, if any dirty on those parts, please clear on time.
- 3、 Please clean the belts after work.
- 4、 Please use OSHIMA cleaning solvent to remove the dirt or glue attached on the surface of the belts.
- 5、 Please use the attached horizon kit to adjust the machine in horizontal for working.
- 6、 For any heavier fabrics, please release the pressure to prevent the machine stuck.

- 7、 All the parameters of thermostat are all set. Please do not adjust the parameters.
- 8、 Please oil the machine regularly. And please replace the cleaning rod' s fabric regularly to keep the machine clean.
- 9、 The fusing piece width can not exceeds the width of machine. Please operate according to the machine size ( 45cm or either 52cm )
- 10、 If your company wants to use to open the side type works, please dismantle the machine unload with bottom mold conjunction pole.
- 11、 Please read the manual before using.

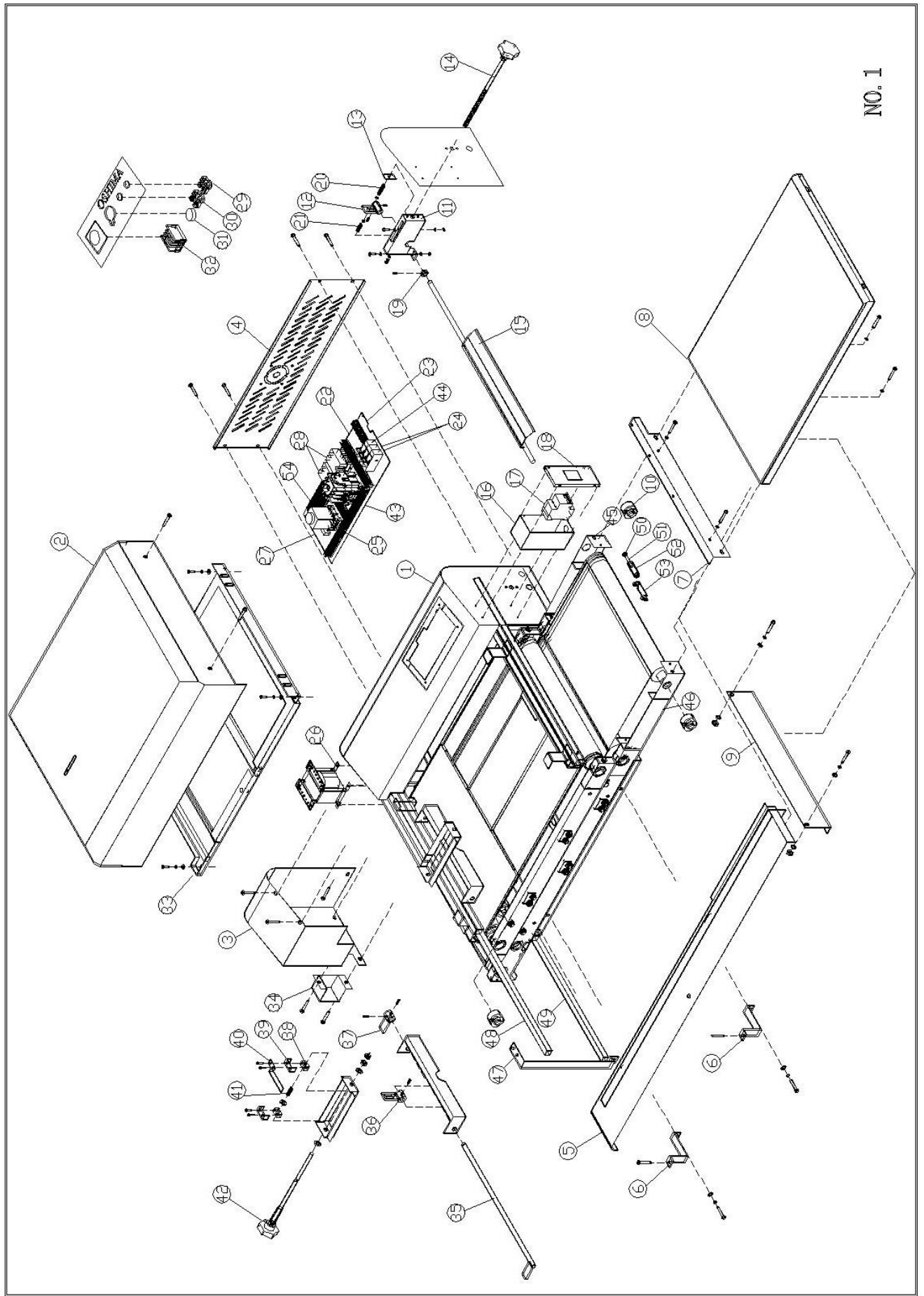

NO. 1

# 机械零件目录 Part list

NO.1

序号	部件编号	部件名称规格		数量	备注
No.	Part no.	Part description/spec.		q'ty	Remark
1	450GA001	機架主體	Main body of machine	1	450G/GS 用
	520GA001	機架主體	Main body of machine	1	520G/GS 用
2	450GA015	前護罩	front protecting	1	450G/GS 用
	520GA015	前護罩	front protecting	1	520G/GS 用
3	450GA003	右護罩	right protecting	1	
4	450GA033	後蓋板	rear cover	1	
5	450GA017	前桌板	front board	1	
	450GA044	前桌板	front board	1	450GSL
6	450GA026	前桌板支持板	underprop of the	2	
7	450GA010	托座	holding seat	1	450G/GS 用
	520GA010	托座	holding seat	1	520G/GS 用
8	520GA016	右桌板	right table board	1	520G/GS 用
	450GA016	右桌板	right table board	1	450G/GS 用
9	520GA011	支座	supporting base	1	520G/GS 用
	450GA011	支座	supporting base	1	450G/GS 用
10	450GB012	軸套	bearing jacket	4	
11	450GA034	下壓力調節座	bottom adjust	1	
12	450GA023	調壓片	adjust pressure	1	
13	450GA031	下壓力調節塊	bottom pressure	1	
14	JD8306	下壓力調節杆 M10*180	bottom pressure	1	
15	450GA012	活動壓板	Active board	1	450G/GS 用
	520GA012	活動壓板	Active board	1	520G/GS 用
16	450GA036	配電盒	electric box	1	
17	DK0401	小型斷路器 2P-C20	breaker	1	
18	450GA037	配電盒蓋	electric box cover	1	
19	JH1060	下壓力壓簧 $\varphi 2.5 * \varphi$	under pressure	1	
20	JH1045	下壓力壓簧 $\varphi 2 * \varphi 15.5 * 55L$	under pressure spring	1	
21	450GB020	活動壓板止環	active board stop	1	
22	450GA035	配電板	electric plate	1	
23	DF0101	端子台 6P 25A	terminal bedplate	1	
24	DF0309	RT14-20 20A 保險管	fused tube	2	
25	DZ0401-3	LSS-32B/220V	motor controller	1	
26	DB0201-1	變壓器 220V/210V	transformer	1	
27	DM0405	2.5UF 電容	capacitance	1	
28	DJ0217-1	SSR-25DA 固態繼電器	solid state relay	2	
29	DD0212	橙色指示燈	orange indicator	1	
30	DA0102	綠色方型(帶鎖,帶燈) 12	green square	1	

# 機械零件目錄 Part list

NO.1-1

序號	部件編號	部件名稱規格		數量	備註
No.	Part no.	Part description/spec.		q'ty	Remark
31	DZ0702	電位器 B20K (B203)	potentiometer	1	
32	DZ0235	溫度控制器	thermostat	1	
33	450GA004	上座	upper seat	1	450G/GS 用
	520GA004	上座	upper seat	1	520G/GS 用
34	450GSA002	撥片器蓋	cover of rotary	1	450GS/520GS 用
35	450GA009	調壓杆	adjust pressure rod	1	450G/GS 用
	520GA009	調壓杆	adjust pressure rod	1	520G/GS 用
36	450GA021	調壓片 (中)	Adjust pressure piece	1	
37	450GA022	調壓片 (左)	adjust pressure	1	
38	450GB018	導塊	block	2	
39	450GA024	導塊固定座	block fixed base	2	
40	450GA025	指示杆	indicator rod	1	
41	JH1067	上壓力彈簧 $\phi$	spring	1	
42	ZW0055	梅花手柄 M10	handle	1	
43	DJ0119-1	交流接觸器	contactor	1	
44	DF0304	RT14-20	fuse tube	1	
45	450GA045	加長型連接座	Lengthen	1	450GSL 專用
46	450GA046	加長型連接座	Lengthen	1	450GSL 專用
47	450GA054	支撐座	support base	1	
48	450GA007	清潔杆	clean pole	1	
49	450GA008	清潔杆	clean pole	1	
50	JB2009	培林 1000086	bearing	2	
51	450GB013	軸銷	Bearing pin	1	
52	450GB014	軸套	bearing jacket	1	
53	450GB031	滑輪固定座	The pulley fixed	1	
54	DF0102	端子台	terminal bedplate	2	

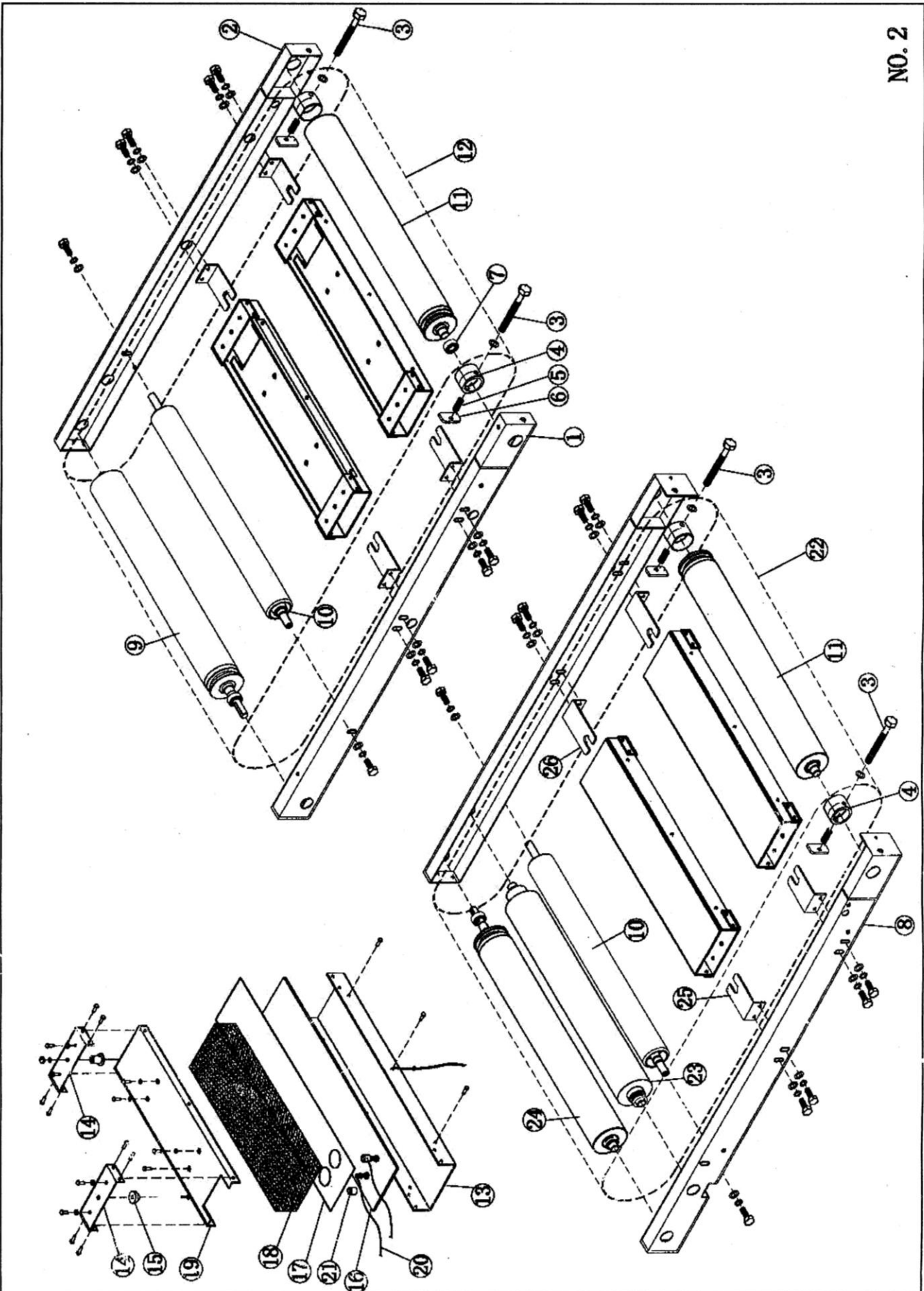

# 机械零件目录 Part list

NO.2

序號	部件編號	部件名稱規格		數量	備註
No.	Part no.	part description/spec.		q'ty	remark
1	450GA006	滾筒座 (上前)	roller seat	1	
2	450GA005	滾筒座 (上後)	roller seat	1	
3	JD1049	外六角螺釘 M8*110	hexagon screw	4	
4	450GB012	滾筒軸承座	roller bearing base	4	
5	JH1044	皮帶張力彈簧 $\phi 2 * \phi 12 * 7 * 28$	belt tension spring	4	
6	450GA030	調整塊	adjust block	4	
7	JB2073	軸承 6202ZC4	bearing 6202ZC4	14	
8	450GA002	滾筒座(下前)	roller seat	1	
9	450GB030	上傳動滾筒	upper transfer roller	1	450G/GS 用
	520GB030	上傳動滾筒	upper transfer roller	1	520G/GS 用
10	450GB026	波浪滾筒	wave roller	2	450G/GS 用
	520GB026	波浪滾筒	wave roller	2	520G/GS 用
11	450GB028	皮帶張力滾筒	belt tension roller	2	450G/GS 用
	520GB028	皮帶張力滾筒	belt tension roller	2	520G/GS 用
12	JP2022	上皮帶 460*1530	upper belt	1	450G/GS 用
	JP2032	上皮帶 520*1530	upper belt	1	520G/GS 用
13	450GB032	電熱器本體	Electro thermal machine body	4	450G/GS 用
	520GB032	電熱器本體	Electro thermal machine body	4	520G/GS 用
14	450GA027	電熱槽固定板	fixed board for electro thermal trough	8	
15	450GB022	襯套 (1)	sleeve (1)	4	
	450GS HEATER	電熱片 (0.8KW, 1.0KW) 各 2	heater	4	450G/GS 用
	520GS HEATER	電熱片 (0.7KW, 1.4KW) 各 2	heater	4	520G/GS 用
17	450GA014	壓板	pressing board	4	450G/GS 用
	520GA014	壓板	pressing board	4	520G/GS 用
18	ZA3113	保溫棉 130*90*30	heat preservation cotton	4	
19	450GA013	內槽	inner trough	4	450G/GS 用
	520GA013	內槽	inner trough	4	520G/GS 用
20	DX0303	高溫線 2.5mm <sup>2</sup> *60	high temperature lead	8	
21	DF0813	絕緣高溫矽膠套 $\phi 10 * 100$	silica gel jacket	8	
22	JP2024	下皮帶 460*1840	lower belt	1	450G/GS 用
	JP2033	下皮帶 520*1840	lower belt	1	520G/GS 用
	JP2072	下皮帶 460*2440	lower belt	1	450GSL 用
23	450GB027	矽膠滾筒	silica gel roller	1	450G/GS 用
	520GB027	矽膠滾筒	silica gel roller	1	520G/GS 用
24	450GB029	下傳動滾筒	lower transfer roller	1	450G/GS 用
	520GB029	下傳動滾筒	lower transfer roller	1	520G/GS 用

25	450GA029	皮帶支持片（短）	belt holding board (short)	4	
26	450GA028	皮帶支撐片（長）	belt holding board (long)	4	



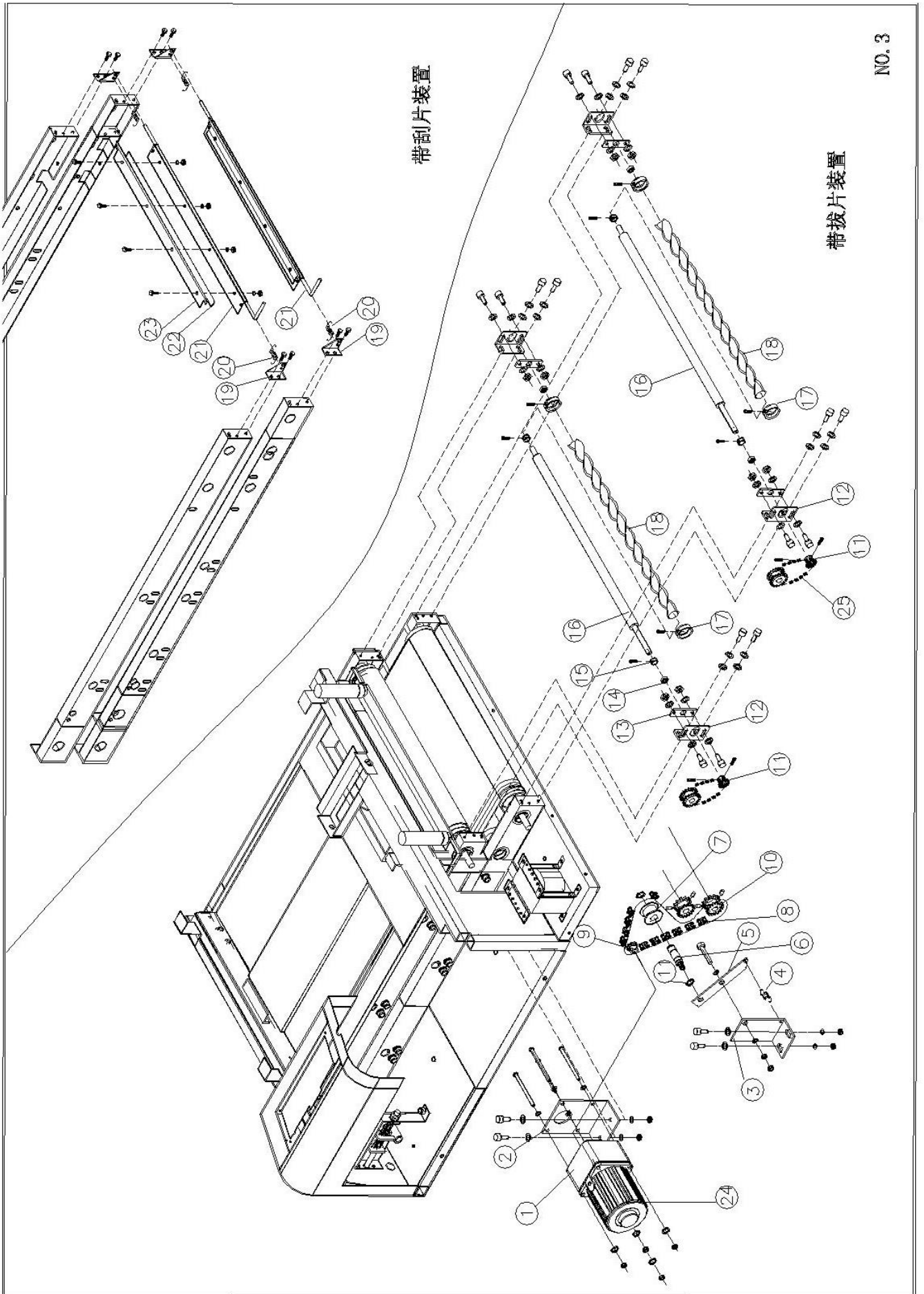

带刮片装置

带拔片装置

NO. 3

# 机械零件目录 Part list

NO.3

序号	部件编号	部件名称规格		数量	备注
No	part no.	part description/spec.		q'ty	remark
1	DM0346-3	YN90-40/90JB50G12	MOTOR + GEAR	1	1 +24 = one set
2	450GA019	馬達座	motor base	1	
3	450GA018	支座	holding seat	1	
4	JH2029	鏈條張力彈簧	chain tensioning spring	1	
5	450GA020	臂	arm	1	
6	450GB011	輪軸	axle	1	
7	450GB010	惰輪	idler wheel	1	
8	JL1001	鏈條	chain	1	
9	450GB017	馬達齒輪	motor gear	1	
10	450GSB005	雙排齒輪	double gear	1	450GS/520GS 用
11	450GSB001	撥片杆齒輪	gear of rotary strip-off rod	2	450GS/520GS 用
12	450GSA004	撥片器固定座	fixed seat of rotary strip-off	4	450GS/520GS 用
13	450GSA003	撥片器固定片	fixed patch of rotary strip-off	4	450GS/520GS 用
14	JB2028	自潤軸承	bearing	4	450GS/520GS 用
15	450GSB002	撥片杆上環	rotary strip-off rod upper ring	4	450GS/520GS 用
16	450GSB004	撥片器杆	rotary strip-off device rod	2	450GS 用
	520GSB034	撥片器杆	rotary strip-off device rod	2	520GS 用
17	450GSB003	撥片杆止環	rotary strip-off rod ring	4	450GS/520GS 用
18	ZA3208	撥片 490mm	rotary strip-off patch	2	450GS 用
	ZA3208-1	撥片 530mm	rotary strip-off patch	2	520GS 用
19	450GA043	刮片固定座	scraper fixed seat	2	450G/520G 用
20	JH3010	刮片座彈簧	pulling spring	4	450G/520G 用
21	450GA048	刮片座	scraper seat	2	450G 用
	520GA043	刮片座	scraper seat	2	520G 用
22	ZA3203	刮片 440*30MM	scraper	2	450G 用
	ZA3206	刮片 498*3*3MM	scraper	2	520G 用
23	450GA047	刮片座蓋	lid for scraper seat	2	450G/520G 用
24	DM0346-3	YN90-40/90JB50G12	MOTOR + GEAR	1	450GS/520GS
25	JL1002	鏈條 25x31 目 (含接目)	chain	2	450GS 用



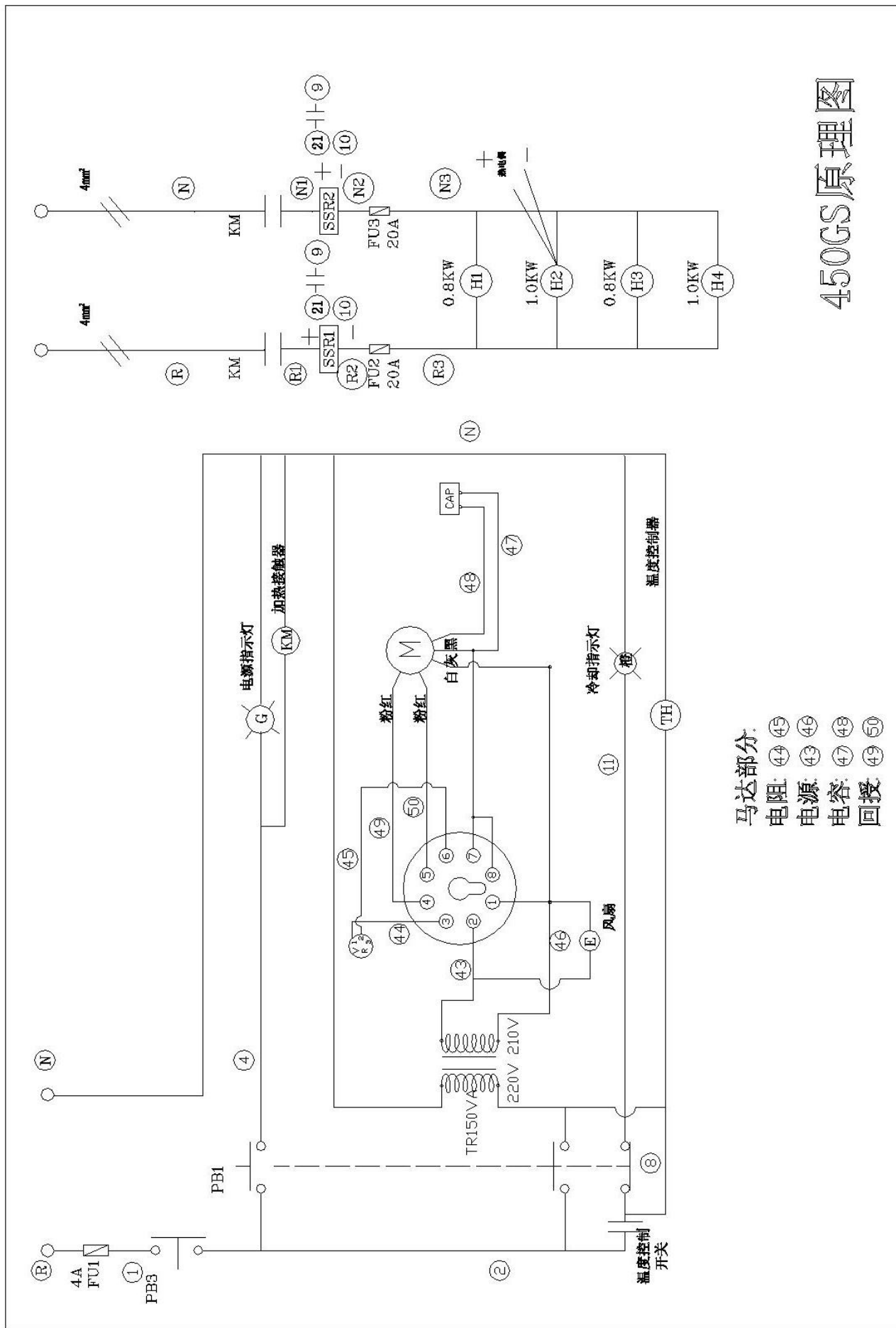

马达部分:  
 电阻: ④⑤ ④⑥  
 电源: ④③ ④④  
 电容: ④⑦ ④⑧  
 回授: ④⑨ ④⑩

450GS原理图

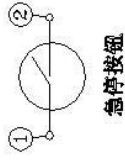
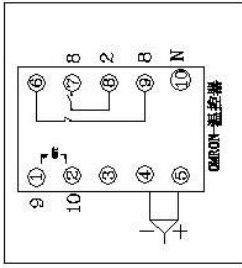
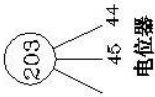
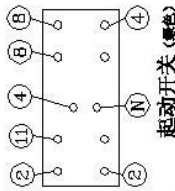
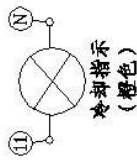

### 450GS 面板电器位置图

12位端子排 (1、4、8、9、10、44、45、N)

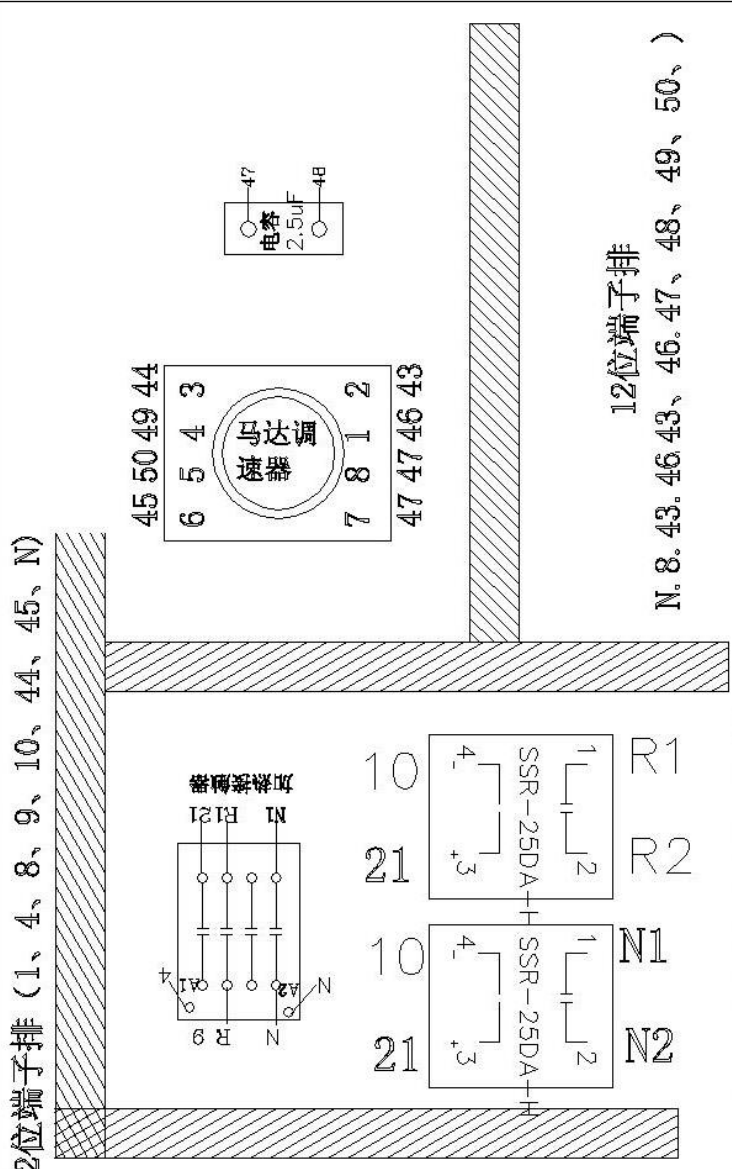
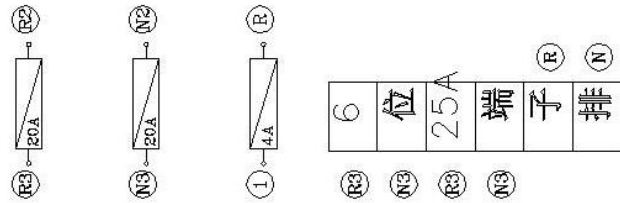

12位端子排  
N. 8. 43. 46. 43、46. 47、48、49、50、)

### 450GS 底板电器位置图

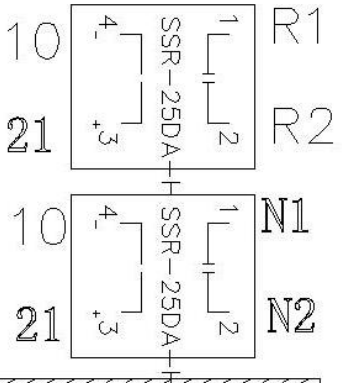
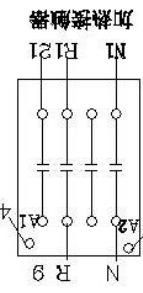
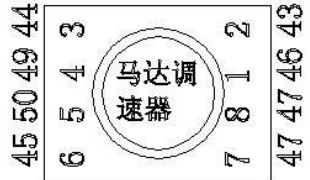
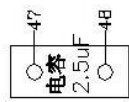
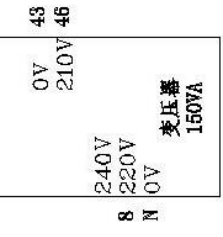

# 随机工具及附件一览表

## Attachment and accessories list

機型及名稱 Model and description		迷你粘合機 Mini fusing machine			
序號	部件編碼	部件名稱規格		數量	備註
No.	part no.	part description/spec.		q'ty	remark
1	ZW0315	工具袋	tool bag	1	
2	JG1063	內六角板手 M2	spanner	1	
3	JG1064	內六角板手 M2.5	spanner	1	
4	JG1065	內六角板手 M3	spanner	1	
5	JG1066	內六角板手 M4	spanner	1	
6	JG1067	內六角板手 M5	spanner	1	
7	JG1089	5#T 型內六角扳手	5# TUBE spanner	1	
8	JG1016	開口板手 8×10	spanner	1	
9	JG1018	開口板手 12×14	spanner	1	
10	DF0309	保險管 20A	fused tube	2	450G/GS 用
11	DF0311-1	保險管 25A	fused tube	2	520G/GS 用
12	DF0304	保險管 4A	fused tube	1	
13	JG6058	螺絲刀(兩用)150mm	screwdriver	1	
14	ZA1015	說明書	manual	1	

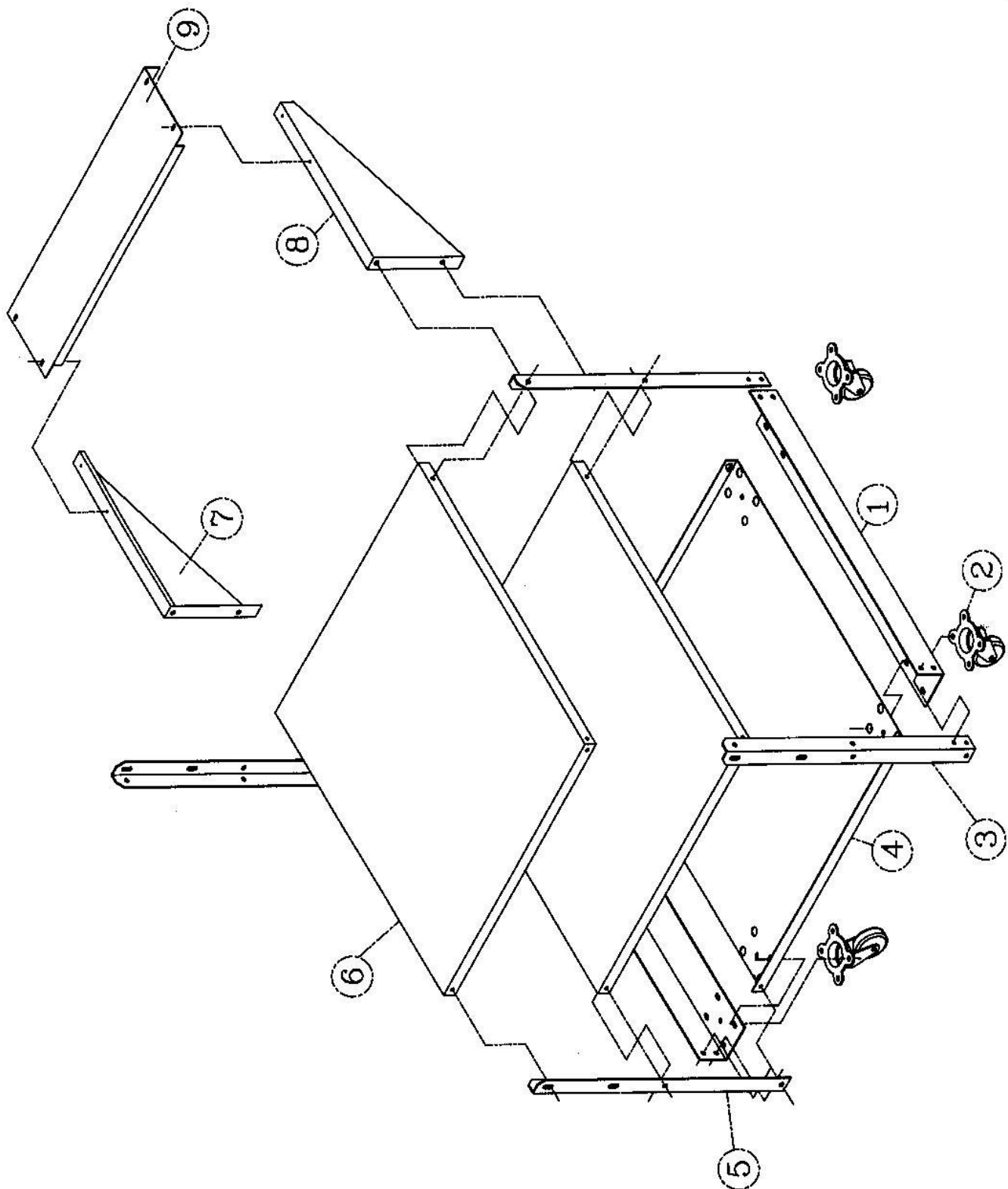

OP-450T

## 机械零件目录 Part list

OP-450T

序號 Ref No	部件編號 Parts No	部件名稱規格 Description	數量 Customer	備註 Remark
1	450T-A005	底梁 Bottom beam	2	
2	ZA0128	肥仔輪 3" Wheel	4	
3	450T-A003	左邊柱 Side pillar	2	
4	450T-A002	底框 Bottom frame	1	
5	450T-A004	右邊柱 The right side pillar	2	
6	450T-A001	下框架 Bottom frame	2	
7	450T-A007	桌板右支撐板 Prop up the plank	1	
8	450T-A006	桌板左支撐板 Prop up the plank	1	
9	450T-A008	桌板 A plank	1	