

**For the professional user**

# Operating Instructions

*Für den professionellen Anwender*

## *Betriebsanleitung*

**Class: 443-1    Ausf. 1**

**Klasse: 443-2    Ausf. 1**

**Dated:**

**Stand:**

## The sign of quality



**Y**ou find the Strobel trademark on every Strobel machine leaving our works. And with good reason. This symbol is a guarantee of the high quality of our products. Quality which creates trust – trust in our technology, our service and, not least of all, in our good name.

## *Im Zeichen der Qualität*

**S**ie finden die Strobel-Schutzmarke auf jeder Strobel-Maschine, die unser Werk verlässt. Und das aus gutem Grund. Denn dieses Zeichen garantiert Ihnen die hohe Qualität unserer Produkte. Qualität, die Vertrauen schafft – in unsere Technik, unseren Service und nicht zuletzt in unseren guten Namen.

**S**trobel clients know that they can expect a particularly high standard of performance from our company and our machines. Now you have settled for one of our products. For us this is a source of encouragement and of obligation to Justify your trust.

If you wish to profit from the performance and efficiency of your Strobel machine as long as possible, exact handling and thorough care is necessary. For this reason we kindly request that you read the operating instructions closely.

It provides all the information you need for trouble free operation.

And if you do happen to need a spare part the enclosed spare parts list gives a complete overview. It is clearly classified according to components so that you can find the required part quickly and easily. In order to avoid errors we request you to quote machine class, machine number and part number completely on your spare part order.

We wish you lots of success in your work with your new Strobel machine.

# Garantiekarte/Warranty Sheet

**STROBEL**

Boschstraße 16  
D-82178 Puchheim  
Tel.: 089/80096-0  
Fax: 089/80096-190  
[info@strobel.biz](mailto:info@strobel.biz)

Maschinenklasse/Machine class: \_\_\_\_\_

Serien-Nr./Serial No: \_\_\_\_\_

Auftrags-Nr./Order Confirmation No: \_\_\_\_\_

Lieferdatum/Delivery Date: \_\_\_\_\_

Rechnungs-Nr./Invoice No: \_\_\_\_\_

Rechnungsdatum/Invoice Date: \_\_\_\_\_

Beanstandung/Complaint: \_\_\_\_\_

\_\_\_\_\_  
\_\_\_\_\_  
\_\_\_\_\_  
\_\_\_\_\_

\_\_\_\_\_  
Datum/Date

\_\_\_\_\_  
Unterschrift/Signature:

*Bitte nicht vom Kunden ausfüllen/To be filled out by Strobel:*

	Datum	Bemerkung
EXA:		
ETA:		
PROD:		
EXA:		
BH:		

## Unterseite / underside

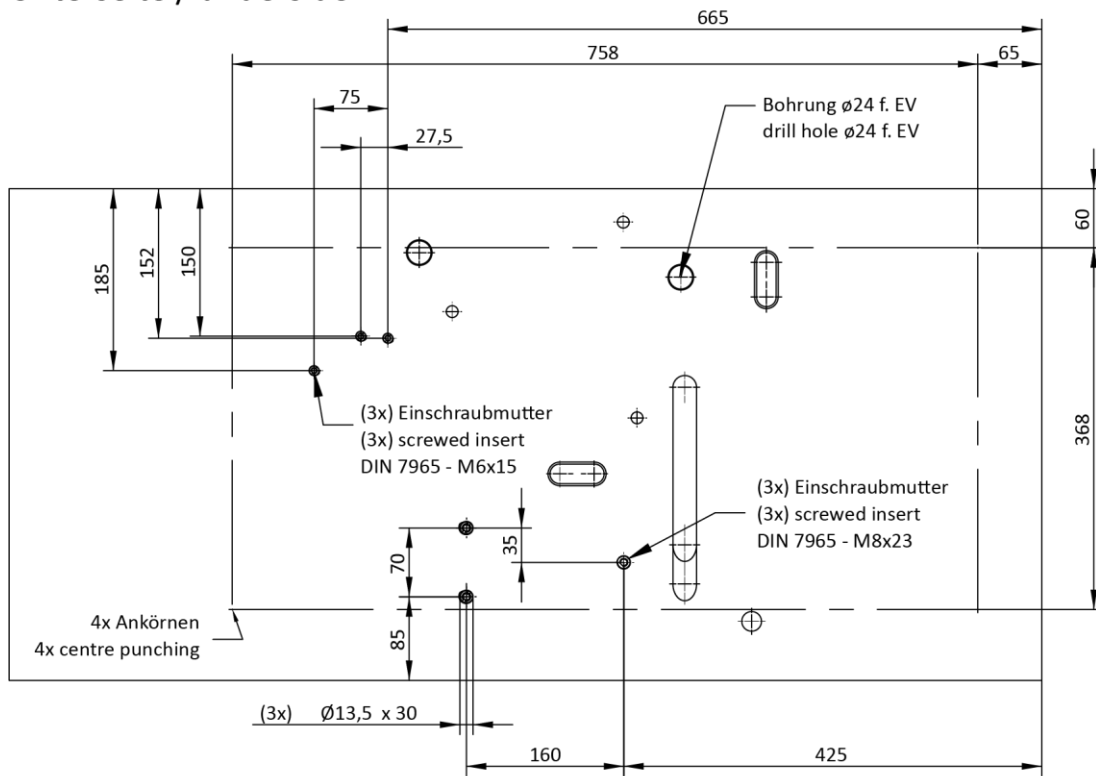

## Oberseite / upperside

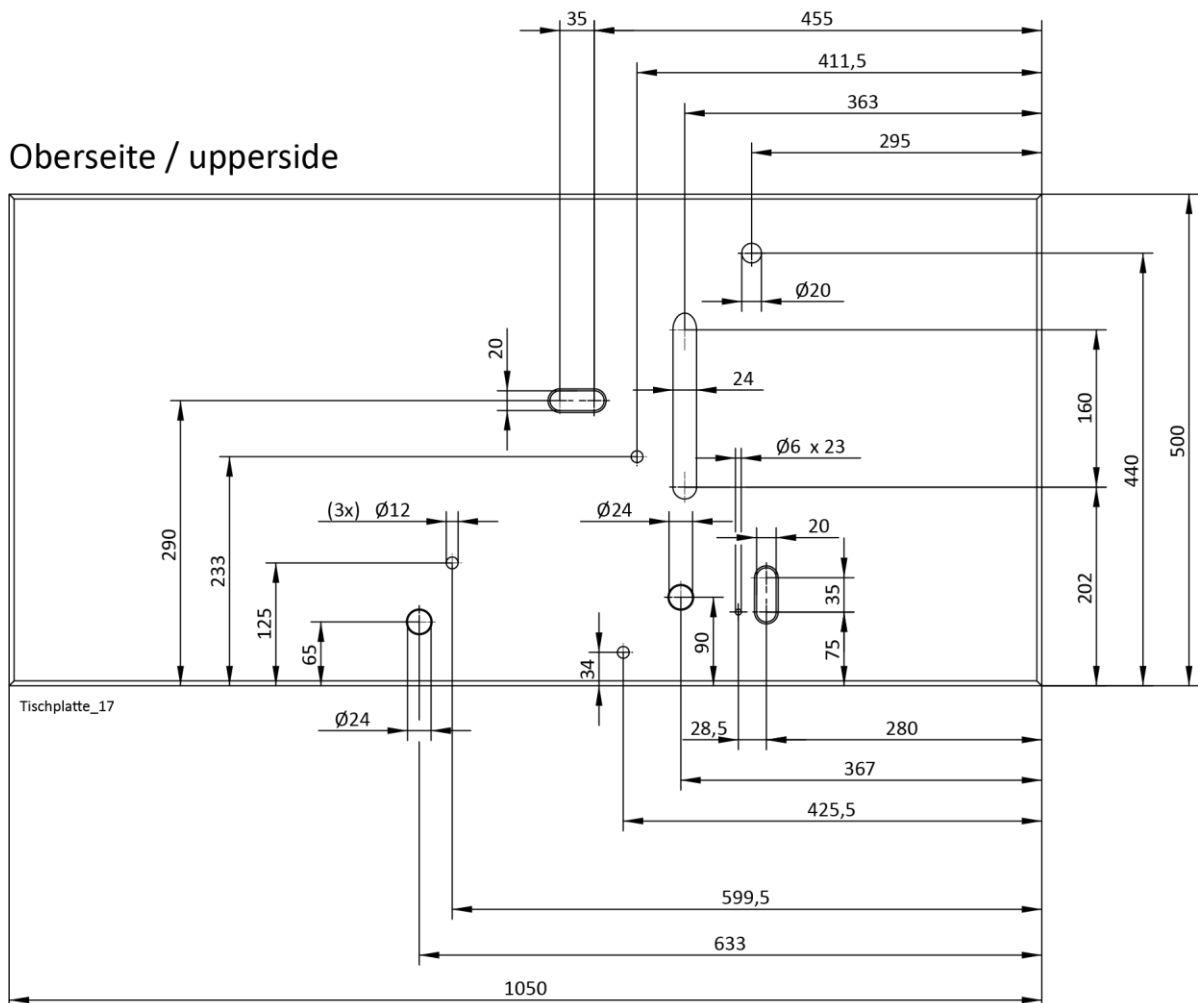



## **Operating Instructions STROBEL Class 443-1 and 443-2**

### **Contents**

1	General notes on safety .....	5
2	General notes .....	7
2.1	Operating instructions .....	7
2.2	Class description, serial number and initial basis for description .....	7
2.3	Range of application and intended use .....	7
2.4	Technical data .....	8
2.4.1	Class 443-1 .....	8
2.4.2	Class 443-2 .....	9
3	Setup and commissioning .....	10
3.1	Unpacking the machine .....	10
3.2	Setting up the machine .....	10
3.3	Direction of rotation on machine (Fig. 2) .....	11
3.4	Motor drive using V-belt or toothed belt (443-2) .....	11
3.4.1	Tension of the toothed belt (Fig. 1) .....	11
3.4.2	Machine positions .....	12
4	Notes on usage .....	15
4.1	Needles and threads .....	15
4.1.1.1	Processing with gathering device .....	16
4.2	Pneumatic gathering device (P-EV) (optional) .....	18
4.2.1	Swivelling down the pneumatic gathering device (P-EV) .....	18
4.2.2	Gathering with class 443-2 .....	18
4.3	Inserting the needle (Fig. 9) .....	20
4.4	Threading and thread routing .....	21
4.5	Thread tension (Fig. 10) .....	21
4.6	Setting the stitch length (Fig. 11) .....	22
4.7	Sewing drive .....	22
5	Maintenance of the machine .....	23
6	Variable sewing tools .....	24

7	Optional features.....	28
7.1	Thread trimmer.....	28
7.2	Pneumatic gathering device (only cl. 443-2) .....	28
8	Switchable Functions.....	29
8.1	DC1200-AB611A Cl. 443-1 .....	29
8.2	DC1500-AB425S Cl. 443-2 .....	30
9	Parameter list .....	31
9.1	DC1200-AB611A Cl. 443-1 .....	31
9.2	DC1500-AB425S Cl. 443-2 .....	34

Subject to change without prior notice



## **1 General notes on safety**

Manuals and additional information can be found on the STROBEL website at:

**<http://www.strobel.biz>**

Every person in charge of setting up, operating, servicing and repairing the machine must first read and understand the operating instructions and particularly the safety instructions before starting up the machine.

**Failure to comply with the following safety instructions can lead to physical injuries or damage to the machine.**

1. The machine must only be operated by persons familiar with the relevant operating instructions and who have been instructed accordingly.
2. Before commissioning also read the notes on safety and the operating instructions of the sewing drive manufacturer.
3. Only use the machine in the intended manner and never without the provided guards. Always observe the pertinent safety regulations.
4. Switch off the main switch or pull the power plug for threading, changing the bobbin, exchanging sewing tools such as needle, hook, stitch plate, transport devices, trimming knife and cutting block, for cleaning and when leaving the workplace as well as for maintenance.
5. General maintenance tasks may be carried out only by properly trained persons in accordance with the operating instructions.
6. Repair work, retrofitting and maintenance may be carried out only by technicians or specially trained personnel.
7. When servicing or repairing pneumatic equipment, the machine must be disconnected from the pneumatic supply. Exceptions are only allowed for adjustment work and tests of functionality performed by specially trained technicians.
8. Only specially qualified technicians may work on the electrical equipment.
9. It is forbidden to work on electrically live components! Exemptions are covered by the EN50110 (DIN VDE0105) regulations.
10. Any retrofitting or alterations to the machine may only be performed under strict compliance with all pertinent safety regulations.
11. Only use our approved spare parts when servicing and/or repairing the machine.
12. It is forbidden to operate the sewing head until it is determined that the entire sewing unit complies with EU provisions.

13. It is essential that you observe and follow these instructions as well as the generally valid safety regulations.
14. Warning instructions given in the operating instructions that pertain to especially dangerous parts of the machine must be indicated at these positions using a safety symbol.



Warning instructions given in the operating instructions that pertain to special injury hazards for operating personnel or technicians must be indicated at these positions using a safety symbol.



## **2 General notes**

### **2.1 Operating instructions**

Every person in charge of setting up, operating, servicing and repairing the machine must first read and understand the operating instructions and particularly the safety instructions before starting up the machine.

### **2.2 Class description, serial number and initial basis for description**

For side-referenced descriptions, the operating side of the machine is the starting base.

The class descriptions (type), the serial and model number (after the hyphen) can be found on the rating plate on the back of the machine.

### **2.3 Range of application and intended use**

#### **Class 443-1**







Single Thread Overseaming Machine with gathering device for attaching soles to shoes made of heavy textile material and leather up to a total thickness of 7 mm.

#### **Class 443-2**

Single Thread Overseaming Machine for attaching soles to shoes made of heavy textile material and leather up to a total thickness of 7 mm, with differential drive.











## 2.4 Technical data

### 2.4.1 Class 443-1

	Empfohlene Nennstichzahl / Recommended rated speed	1800 min-1
	Stichlänge / stitch length	3,0 - 7,0 mm Auslieferungszustand / delivery condition 4,5 mm
	Nadelsystem / needle system Nadelstärke / needle size	GROZ-BECKERT 134 140/22 LR
	Nadelhöhenverstellung / Adjustable needle height	
	Fadenabschneider pneumatisch / thread trimmer pneumatic	Optional
	Fadenspannung / thread tension Faden / thread	Auslieferungszustand / delivery condition 150 cN Polyester, endlos gezwirnt 40/ polyester continuous filament 40
	Freiraum / free space	60 mm
	Einhaltevorrichtung manuell / Gathering device manually	

<b>Technischer Auslieferungszustand / delivery condition:</b>	
Riemenscheibendurchmesser Maschine/ machine pulley diameter	dw 80 mm
Keilriemen-Profil / V-belt profile	10 x 6 mm
Stichart / stitch type	Einfaden-Überwendlichstich Typ 501 / single-thread overcast stitch type 501
Anschluss pneumatisch / pneumatic connection	6 bar
Luftverbrauch, Mittelwert / average air consumption	abhängig von der Ausstattung / depending on the equipment
Stellfläche / Foot print	0,5 m x 1,1 m
Arbeitsgeräusch / operating noise at 1800 min-1 nach DIN 45635-48-1 KL3	LpAm 71 dB(A)

## 2.4.2 Class 443-2

	Empfohlene Nennstichzahl / Recommended rated speed	1800 min-1
	Stichlänge / stitch length	3,0 - 7,0 mm Auslieferungszustand / delivery condition 4,5 mm
	Programmierbar / programable	
	Differential-Tellertransport / differential cup feed	REDUZIERBAR bis / REDUCIBLE until 50%
	Nadelsystem / needle system Nadelstärke / needle size	GROZ-BECKERT 134 140/22 LR
	Nadelhöhenverstellung / Adjustable needle height	
	Fadenabschneider pneumatisch / thread trimmer pneumatic	optional
	Fadenspannung / thread tension Faden / thread	Auslieferungszustand / delivery condition 150 cN Polyester, endlos gewirnt 40/ polyester continuous filament 40
	Freiraum / free space	60 mm
	Einhaltvorrichtung pneumatisch / Gathering device pneumatic	optional

<b>Technischer Auslieferungszustand / delivery condition:</b>	
Motor-Leistung min. / min. motor power	550 W
Zahnriemenscheibe Maschine / toothed belt pulley/machine	Z = 38
Zahnriemenprofil / toothed belt profile	HTD 5M-9
Stichart / stitch type	Einfaden-Überwendlichstich Typ 501 / single-thread overcast stitch type 501
Anschluss pneumatisch / pneumatic connection	6 bar
Luftverbrauch, Mittelwert / average air consumption	abhängig von der Ausstattung / depending on the equipment
Stellfläche / Foot print	0,5 m x 1,1 m
Arbeitsgeräusch / operating noise at 1800 min-1 nach DIN 45635-48-1 KL3	LpAm 76,1 dB(A)

## 3 Setup and commissioning

### 3.1 Unpacking the machine

Strobel machines are supplied either complete as upper part only.

The cotton stand and another machine accessories are located in the packaging.

Prior to disposing of the packing material it must be carefully checked whether all accessories parts have been unpacked.

### 3.2 Setting up the machine



#### **CAUTION ! Danger of injury!**

Due to pulling in of parts of clothing or hair as well as **danger** of crushing of fingers!

The machine must not be operated without a guard for the belt for the upper part and for the motor.

If the stand is not also supplied by us, but the machine is placed on a different stand, then the tabletop needs to be prepared as shown in the tabletop drawing and the lifting gear rods and the actuation gear rods for the motor need to be mounted.

#### **Class 443-1**

Screw on the motor. The electrical connection must be made according to the circuit diagram in the online manuals.

If the upper part is delivered with attached compact motor, the control box and the set-point adjuster has to be mounted underneath the tabletop. Additionally the actuation gear rods need to be mounted between set-point adjuster and pedal.

Check that all screws on the stand are firmly installed and retighten if necessary.

Install the position generator and set according to point "3.4.2 Machine positions".



#### **A T T E N T I O N !**

Before starting the machine, check that the electrical specifications given on the type plate of the motor, in particular the network voltage and frequency, are appropriate for your electric system and that all other connection values, e.g. for air, comply with the values specified on the machine and in the operating instructions.

### 3.3 Direction of rotation on machine (Fig. 2)

When facing the handwheel, turn it in a clockwise direction.

### 3.4 Motor drive using V-belt or toothed belt (443-2)

#### 3.4.1 Tension of the toothed belt (Fig. 1)



#### **CAUTION ! Danger of injury!**

To check the tension of the toothed belt, switch off the machine electrically and depress the motor switch pedal to make sure that the machine is truly switched off.

Never operate the machine without the belt cover for the motor.

The toothed belt must not be tensioned too much. You should be able to depress it easily with your thumb by about 5 mm.

Too little or too great tooth-belt tension can be bad for the machine's positioning and thus impair the function sequence.

Tension the tooth-belt (Fig. 1):

- Loosen the upper and lower fastening screws (1), (2) on the machine upper part.
- Pull motor out a little and slightly tighten the lower fastening screw (2).
- Tension the toothed belt by swivelling the motor.
- Retighten top and bottom fastening screw (1), (2).

**Fig. 1**

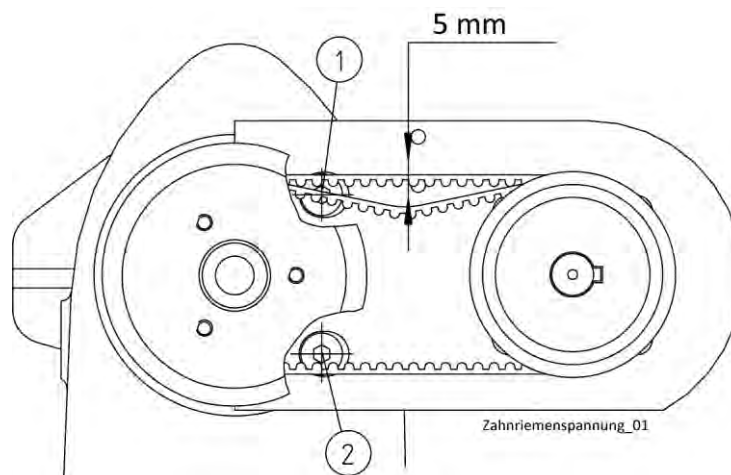

## 3.4.2 Machine positions



### **CAUTION ! Danger of injury!**

When setting the position generator and testing the position while the machine is on, keep fingers and hands away from all moving parts, otherwise there is **danger** of fingers getting crushed, bodily injuries, needle punctures and entanglement of clothing.

(See also instructions of the motor manufacturer)

#### **General:**

The stop motors require a position generator that detects the mechanical position of the machine at the main shaft and sends it to the motor's control. (Fig. 2)

The proper position of the position generator to the flange is marked on complete machines with a spot of paint.

To adjust or remove, loosen the two clamping screws (1) Fig. 2. Retighten them well before restarting.

**Fig. 2**

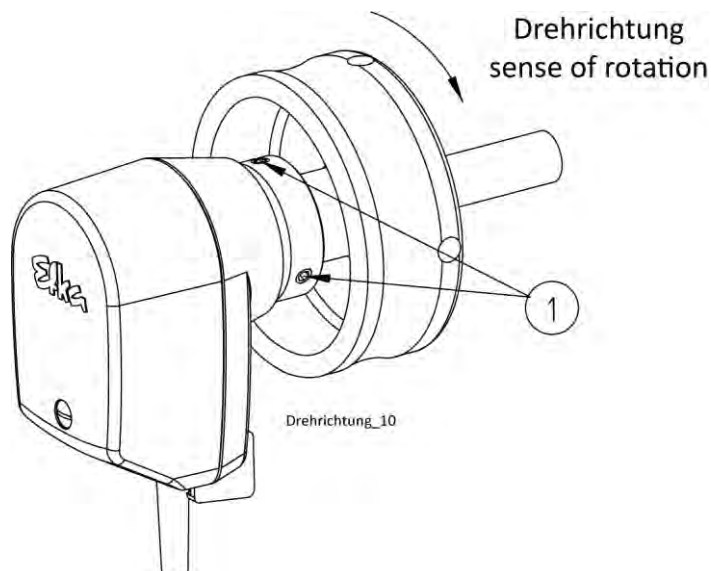



## Machines with or without gathering device:

The machine requires two needle positions and, depending on sewing drive, possibly also a reference position.

Reference position (Fig. 3):

The reference position needs to be set so that the point of the needle concludes with the outer plate edge in the direction of the piercing.

**Fig. 3**

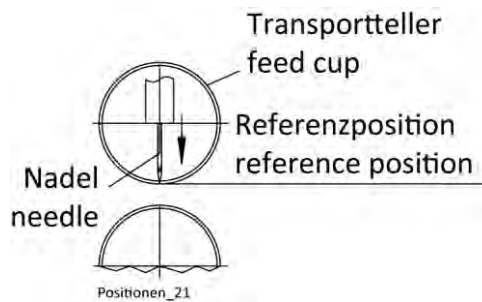

Needle position (when stop inside the stitch with pedal position "0" (Fig. 4)):

The needle position needs to be set so that the distance between the outer plate edge in the direction of the piercing and the point of the needle is about 10 mm.

The needle position is position 2 at the sewing drive.

**Fig. 4**

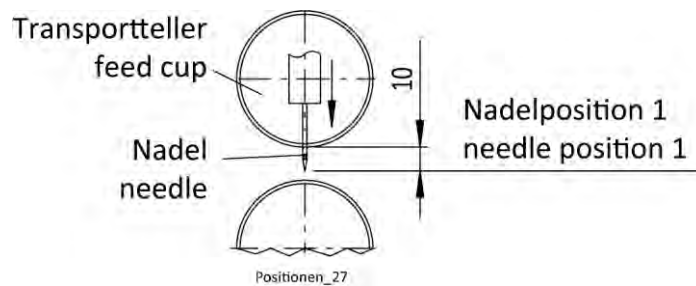

Needle position (when stop outside the stitch with pedal position “-2” (Fig. 5)):

The needle position needs to be set so that the distance between the point of the needle in the direction of the piercing and outer plate edge is about 4 mm.

The needle position is position 2 at the sewing drive.

**Fig. 5**

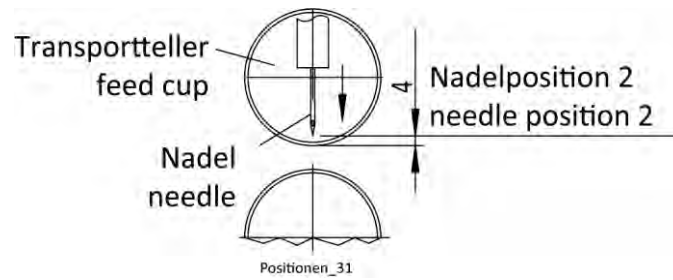

## 4 Notes on usage

### 4.1 Needles and threads

The sewing quality can be improved by using the most favourable needles and threads for the respective sewing material to be produced.

Only use approved GROZ-BECKERT needle system 134.

The machine is delivered with needles of size 140/22.

**Note:** An intact needle is very important for ensuring good quality stitches. Bent needle points, which may only be visible under a magnifying glass, will lead to poorer sewing results.

Replace your needles in time!

We recommend using continuously twined polyester threads of thickness 40. Due to their high strength and good sliding behaviour at a small thread size, they are preferable to spun thread.

**Note:** When assembling fixed parts, note that occasionally there is a gumming up of the eye of the needle that can cause interfere with the loop formation.



#### **G u a r a n t e e   n o t e !**

This machine has been configured and broken in using **original GROZ-BECKERT needles**.

No guarantees can be given when the machine is readjusted for the use of different needles.

## 4.1.1.1 Processing with gathering device

With class 443-1, the insole is sewed to the shoe vamp. A gathering device facilitates the maintaining of the extended sizes of the vamp tips on vulcanized as well as light leather shoes. It reliably affects a completely cordless stitch and the complete covering during subsequent vulcanization in the press.

The gathering device (EV) (1) is actuated by the left pedal so that when the pedal is pressed forward, the lever with the material guide (2) (Fig. 6) of the gathering device (1) is swivelled between the Feed cups (5) by the rods (3) and pivot arm (4). When the pedal is pressed back, the EV (1) is swivelled upwards. To swivel the EV (1) up or down, the Front cup needs lifted first by the knee lever (6).

The extended sizes occurring on various types of shoes can be processed uniformly by the EV. The sewer swivels the EV down at a marking previously specified at the vamp and sole. (Fig. 7).

To make handling and gripping times significantly easier and shorter, it is recommended to equip the machines with the gathering device – if this has not been carried out already – with a stop motor with two needle positions:

1st position	=	Needle position front,
2nd position	=	Needle position rear.

The 1st needle position is important during the swivelling down of the material guide (2) so that the shoe can be held in the same stitch position as the Feed cups are lifted; the 1st position also belongs to the threading.

The 2nd needle position belongs to the inserting and removal of the material.

Operation of the machine is done as follows (see also Fig. 6):

- Right pedal : Motor
- Left pedal : Gathering device
- Knee lever, right : Lifting the machine off

The knurled screw (7) is used to set how far the material guide (2) should swivel down into the material. Once the desired swivel width has been set, counter it with the knurled nut (8). (Fig. 6)

**Fig. 6**

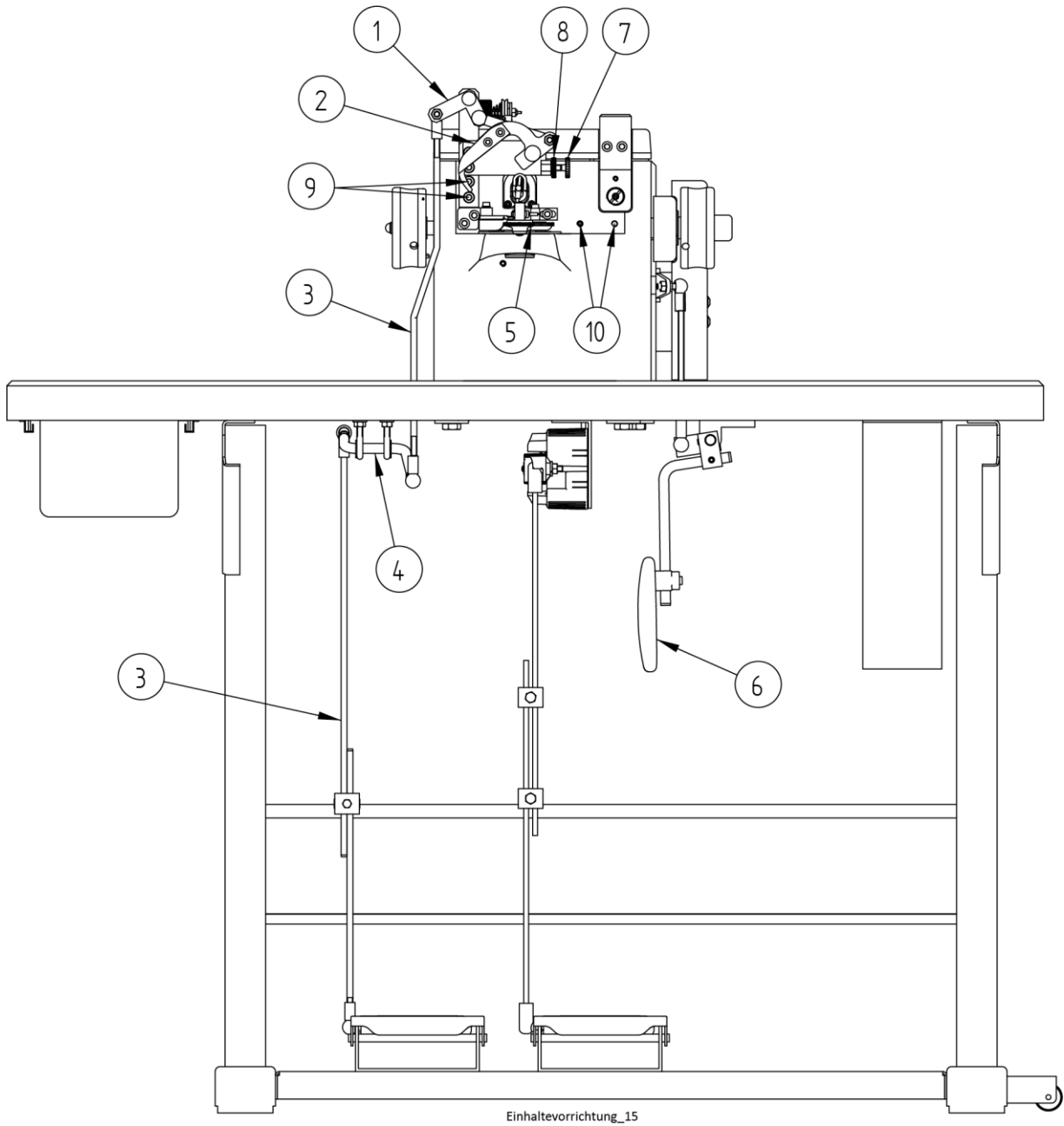

**Fig. 7**

In diesem Bereich  
EV einschwenken

swivel down the  
gathering device  
in this range

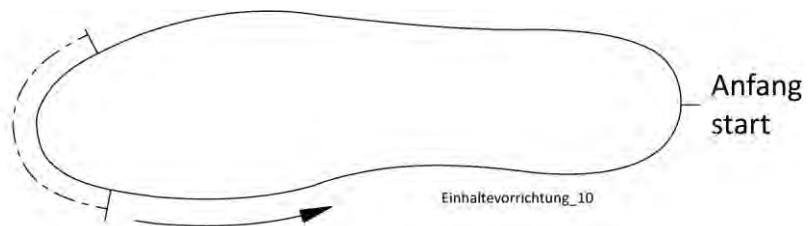

Nährichtung  
sewing direction

## **4.2 Pneumatic gathering device (P-EV) (optional)**

### **4.2.1 Swivelling down the pneumatic gathering device (P-EV)**

Before swivelling the P-EV in, the knee lever (1) must be moved with the right knee so that the disk arm is released, only then can the left pedal (2) and the separating plate (3) is swung in. The swiveling-in of the Separator plate (3) can be adjusted via a throttle (4). The swivel out occur in reverse order and unthrottled. (Fig. 8)

With the knurled screw (7) you can adjust how far the material guide (2) can be the material should be swivelled in. If the desired swinging distance is adjusted, this is countered with the knurled nut (8). (Fig. 6)

### **4.2.2 Gathering with class 443-2**

This machine is equipped with a differential drive, which runs synchronously and can be continuously reduced up to 50 % by means of the left foot pedal (step forward) will be.

With the optional additional equipment 398.0663 knee switch and control panel (plus software release) the shirring can also be controlled by a program.

If shirring via the differential transport is not sufficient, the optionally available pneumatic gathering device can be used additionally.

#### **IMPORTANT:**

The following must be observed to ensure that the pneumatic hold-down device can be correctly inserted:

- For manual differential transport, the left foot pedal must be depressed, i.e. maximum value of differential transport (when the control unit is attached, the value 9 appears)
- If a sewing program is used, the value 9 (maximum differential feed) must be programmed when using the pneumatic gathering device.

If this is not the case, the functionality of the pneumatic gathering device will be impaired. If the differential feed is not set to maximum, the differential feed and the pneumatic hold-open device work against each other.

Fig. 8

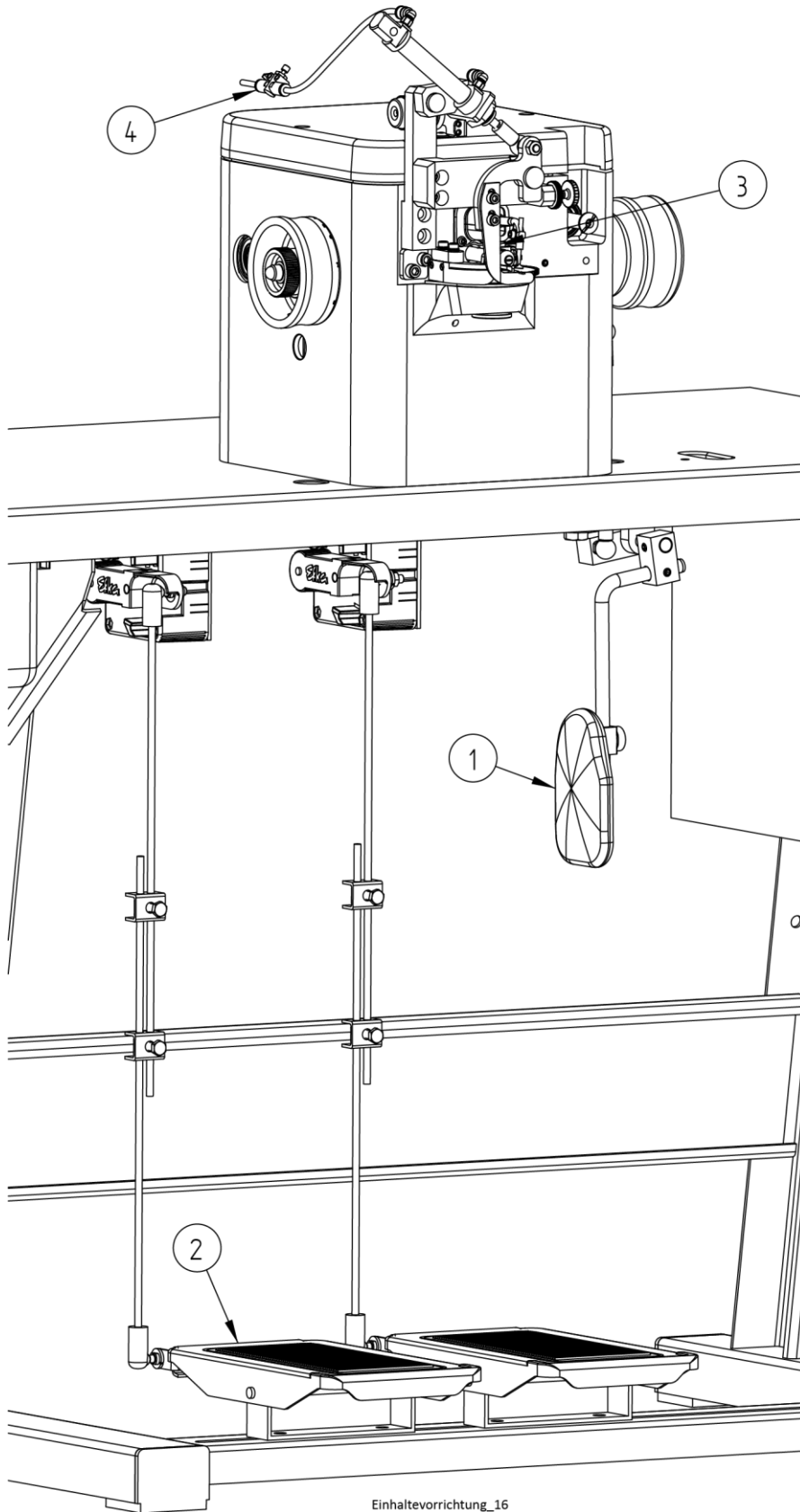

Einhaltevorrichtung\_16

## 4.3 Inserting the needle (Fig. 9)



### **CAUTION ! Danger of injury!**

Before replacing the needle, switch off the machine electrically, and depress the motor switch pedal to make sure that the machine is truly switched off.

Otherwise there is a **danger of injury** from crushing and needle punctures.

The needle is fed in downwards with the long groove and pushed back until it contacts the stud (1). Then the needle is clamped tight with the screw (5).

**Fig. 9**

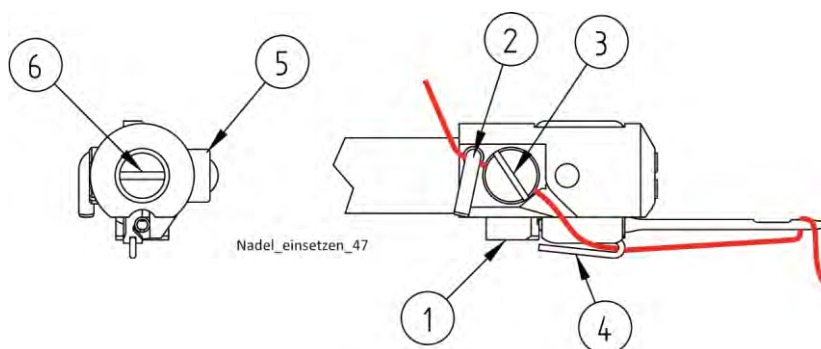



## 4.4 Threading and thread routing



### **CAUTION! Danger of injury!**

Before threading, switch off the machine electrically and depress the motor switch pedal to make sure that the machine is truly switched off.

Otherwise there is a **danger of injury** from crushing and needle punctures.

Fig. 9 and Fig. 10 show the correct threading.

**Fig. 10**

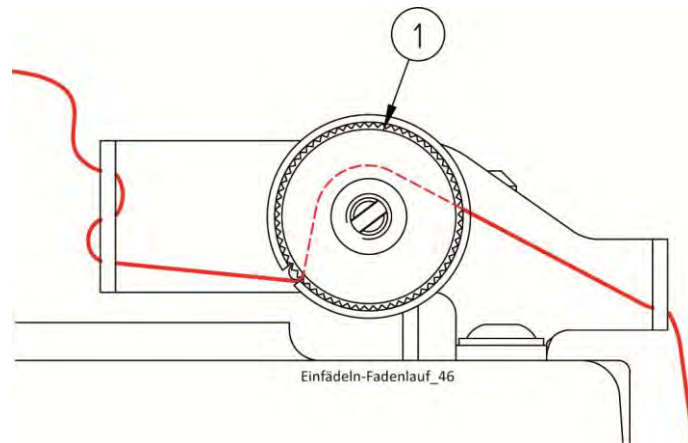

## 4.5 Thread tension (Fig. 10)

Depending on the quality, properties and thickness of the thread, the thread tension is adjusted using the thread tension nut (1). Thick, firm thread requires a firm thread tension.

## 4.6 Setting the stitch length (Fig. 11)



### **CAUTION! Danger of injury!**

Before setting the stitch length, switch off the machine electrically and depress the motor switch pedal to make sure that the machine is truly switched off.

Otherwise there is a **danger of injury** from crushing and needle punctures.

The infinitely adjustable stitch length adjustment is done, as Fig. 11 shows, by the control knob (1) located inside the left handwheel which features a pointer (2) that reaches through a groove "S" of the control knob.

The handwheel features scale markings with numerals to which the end of the pointer (2) is set.

The numerals on the left handwheel represent the stitch length approximately.

**Fig. 11**

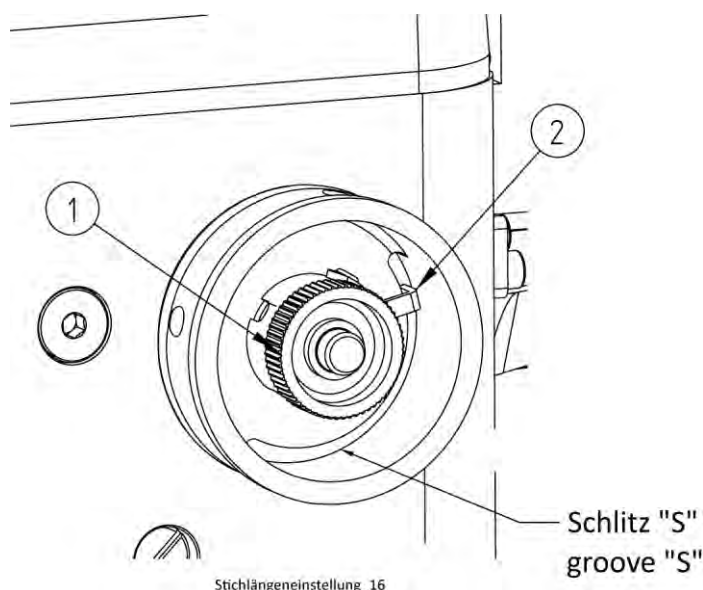

## 4.7 Sewing drive

The standard versions of the machines of class 443-2 are delivered with DC sewing drives AB425.

It needs to be noted that with these sewing drives, the stitch numbers, direction of rotation, switch times can for instance be adjusted only by programming.

The machine stitch number can be influenced by changing. The detailed procedure using programming can be found in the mechanic instructions.

## 5 Maintenance of the machine

Check the cam (1) and the sliding block (2) every 3 months and relubricate if necessary. (Fig. 12)

Recommended and enclosed lubricant: Molykote G-RAPID plus

**Fig. 12**

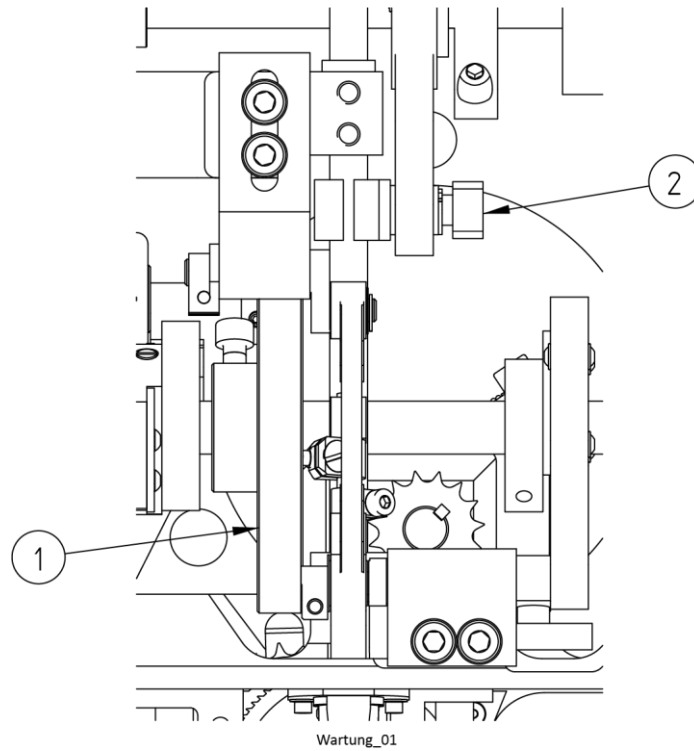

Check the chain play of the chain (1) every 3 months and retighten if necessary. (Fig. 13)

**Fig. 13**

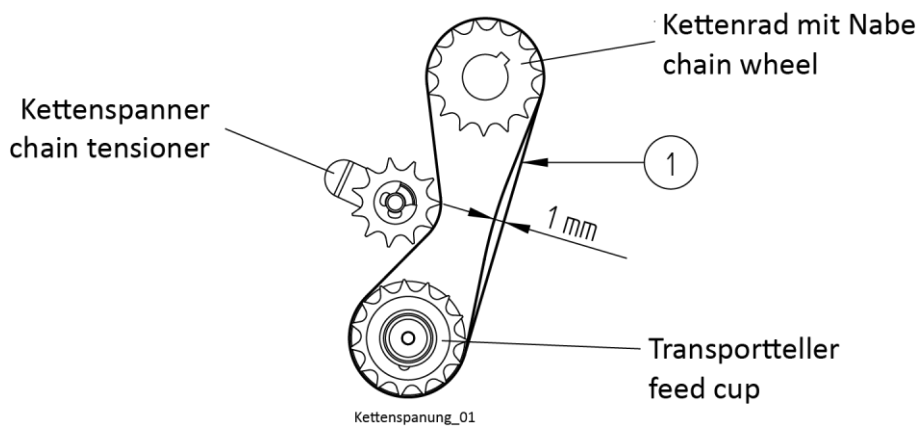

## 6 Variable sewing tools



### **CAUTION ! Danger of injury!**

Before threading, switch off the machine electrically and depress the motor switch pedal to make sure that the machine is truly switched off.

Otherwise there is a **danger of injury** from crushing and needle punctures.

The following table lists the available sewing tools.

## Feed cups

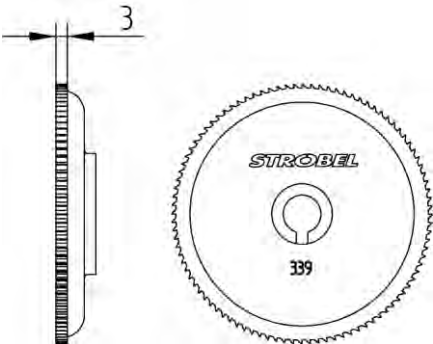
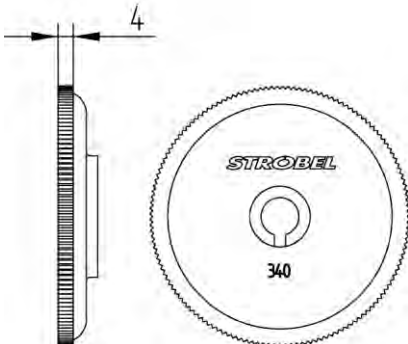
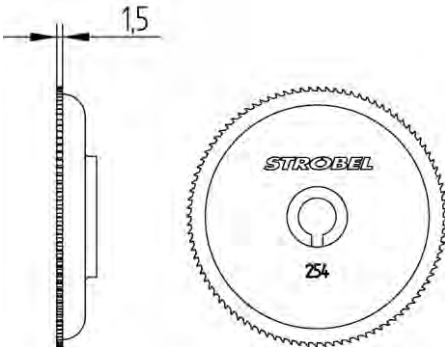
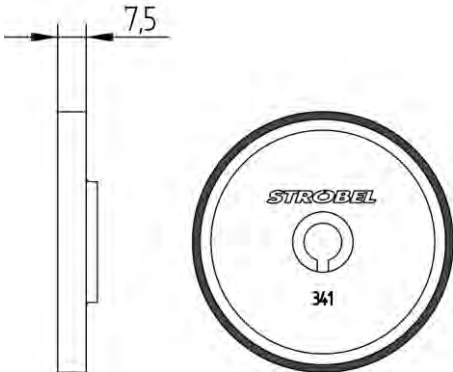
<p style="text-align: center;"><b>Standard</b> Cl. 443-1, -2</p>  <p><b>182.0339</b> Feed cup sawtooth Ø68.75 mm, Pitch 2,25 mm</p>	<p style="text-align: center;"><b>Optional</b> Cl. 443-1, -2</p>  <p><b>182.0340</b> Feed cup Ø68.75 mm, Knurl pitch 1,5 mm</p>
<p style="text-align: center;"><b>Optional</b> Cl. 443-1, -2</p>  <p><b>182.0254</b> Feed cup sawtooth Ø68.75 mm, Pitch 2,25 mm</p>	<p style="text-align: center;"><b>Optional</b> Cl. 443-1, -2 for sewing material, sensitive to markings</p>  <p><b>182.0341</b> Feed cup Ø69 mm, coated with natural rubber</p>

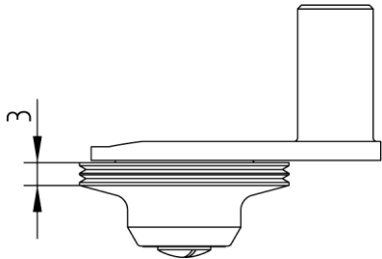
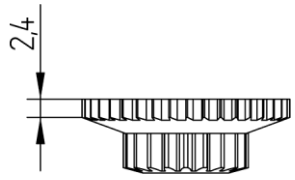
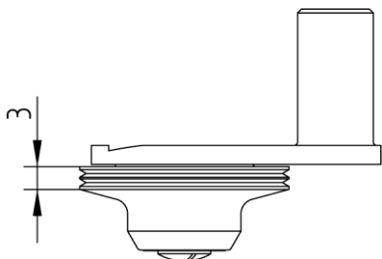
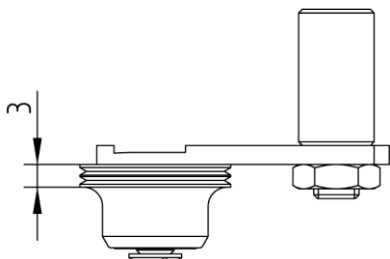
Front cup	
<p style="text-align: center;"><b>Standard</b> Cl. 443-1</p>  <p>382.0227 Front cup <math>\varnothing 27.7</math> mm – fluted</p>	<p style="text-align: center;"><b>Standard</b> Cl. 443-2</p>  <p>282.0338 Front cup <math>\varnothing 27.5</math> mm – sawtooth</p>
<p style="text-align: center;"><b>Optional</b> Cl. 443-1</p>  <p>482.0227 Front cup <math>\varnothing 27.7</math> mm – fluted with material support</p>	<p style="text-align: center;"><b>Optional</b> Cl. 443-1</p>  <p>482.0229 Front cup <math>\varnothing 20</math> mm – fluted with material support</p>

## Material guides

**Standard**  
Cl. 443-1,-2

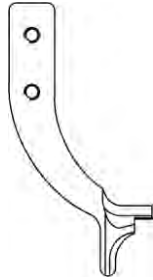

186.0459  
Material guide - 3,5 mm high

**Optional**  
Cl. 443-1, -2

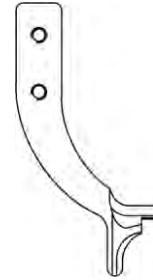

186.0458  
Material guide - 4,5 mm high

## **7 Optional features**

The following equipment is additionally available for the machine and can be ordered from the factory together with the machine or as an attachment kit:

### **7.1 Thread trimmer**

398.0718      Thread trimmer pneumatic  
Prerequisite here is the use of the  
EFKA DC 1200/AB611A with connection line (Cl. 443-1)  
EFKA DC 1500/AB425S with connection line (Cl. 443-2)

### **7.2 Pneumatic gathering device (only cl. 443-2)**

314.1016      Pneumatic gathering device



## 8 Switchable Functions

### 8.1 DC1200-AB611A Cl. 443-1

		Machine class			
		Setting range	Preset at mode 56	443-1	443-1F
Explanation: 0 = Off 1 = On					
F-290	Mode	00 56	56	56	56
"Control"	Button "E" Seg1 Softstart ON/OFF	0 1	0	0	0
	Button "E" Seg2 Not assigned	0 1	0	0	0
	Button "+" Seg3 Thread trimmer ON/OFF	0 1	0	0	0
	Button "+" Seg4 Output M3 ON/OFF	0 1	0	0	0
	Button ">>" Seg5 Basic position "Needle position 1"	0 1	0	1	1
	Button ">>" Seg6 Basic position "Needle position 2"	0 1	1	0	0
	Button "-" Seg7 Automatic lifting in the seam	0 1	0	0	0
	Button "-" Seg8 Automatic lifting at the seam end	0 1	1	1	1
Stand: 11.01.2021 - PT_AB611A_443-1_210111					

## 8.2 DC1500-AB425S Cl. 443-2

		Machine class			
		Setting range	Preset at mode 56	443-2	443-2F
Explanation: 0 = Off 1 = On					
F-290	Mode	00 56	56	56	56
"Control"	Button "E" Seg1 Softstart ON/OFF	0 1	0	0	0
	Button "E" Seg2 Not assigned	0 1	0	0	0
	Button "+" Seg3 Thread trimmer ON/OFF	0 1	0	0	0
	Button "+" Seg4 Output M3 ON/OFF	0 1	0	0	0
	Button ">>" Seg5 Basic position "Needle position 1"	0 1	1	1	1
	Button ">>" Seg6 Basic position "Needle position 2"	0 1	0	0	0
	Button "-" Seg7 Automatic lifting in the seam	0 1	0	0	0
	Button "-" Seg8 Automatic lifting at the seam end	0 1	1	1	1
Stand: 11.01.2021 - PT_AB425S_443-2_210111					

## 9 Parameter list

### 9.1 DC1200-AB611A Cl. 443-1

		Machine class				
		Setting range	Unit	Preset at mode 56	443-1	443-1F
F-467	Motor selection	1 10		3	3	3
F-290	Mode	00 56		56	5	5
F-365	Machine classes selction	0 2		0	0	0
F-013	Thread trimmer OFF/ON	0 1		0	0	1
F-014	Output 3 OFF/ON	0 1		0	1	1
F-019	Lifting with pedal position "-1"	0 4		3	3	3
F-026	Characteristic of the pedal EB401	0 4		4	4	4
F-100	Stitch number softstart	000 254		002	002	002
F-110	Positioning speed n1	070 390	min-1	200	200	200
F-111	Maximum speed n2- (setting range)	n2_ 9900	min-1	2200	1800	1800
F-115	Softstart speed n6	0070 1500	min-1	0500	0500	0500
F-121	Lower limit of the n-max setting range	0200 n2-	min-1	0200	0200	0200
F-134	Softstart OFF/ON	0 1		0	0	0
F-153	Holding force during machine standstill	00 50		05	05	05

		Machine class				
		Setting range	Unit	Preset at mode 56	443-1	443-1F
F-161	Direction of rotation of the motor	0 1		0	0	0
F-180	Number of turn-back steps	000 359	Degree	040	175	175
F-181	Switch delay for turn back	000 990	ms	200	010	010
F-182	Turn back OFF/ON	0 1		0	0	0
F-207	Braking effect when changing the set-point <= 4 steps (indicated valus only with transmission ratio 1:1)	00 55		15	15	15
F-208	Braking effect when changing the set-point >= 5 steps (indicated valus only with transmission ratio 1:1)	00 55		20	20	20
F-219	Positioning force when stopping the drive	00 55		04	04	04
F-220	Accelerating power of the drive (indicated valus only with transmission ratio 1:1)	00 55		20	20	20
F-234	Restarting after activated run inhibition	0 1		1	0	1
F-240	Selecting the input function In.1	00 47		00	00	00
F-270	Selection o9f the position sensors	0 6		0	6	6
F-272	Transmission motor shaft to machine shaft	0150 9999		1000	1000	1000
F-280	Delay time Thread trimmer (M1)	0000 5000	ms	0100	0000	0000
F-281	On-time Thread trimmer (M1)	0000 5000	ms	0180	0100	0100

		Machine class				
		Setting range	Unit	Preset at mode 56	443-1	443-1F
F-284	Delay time Output M3	0000 5000	ms	0000	0200	0200
F-285	On-time Output M3	0000 5000	ms	0300	0100	0100
F-288	Delay time till lifting On	0000 5000	ms	0200	0380	0380
Stand: 11.01.2021 - PT_AB611A_443-1_210111						

## 9.2 DC1500-AB425S Cl. 443-2

		Machine class				
		Setting range	Unit	Preset at mode 56	443-2	443-2F
F-467	Motor selection	1 10		3	1	3
F-290	Mode	00 56		56	5	5
F-365	Machine classes selction	0 2		0	1	0
F-013	Thread trimmer OFF/ON	0 1		0	1	1
F-014	Output 3 OFF/ON	0 1		0	1	1
F-019	Lifting with pedal position "-1"	0 4		3	3	3
F-026	Characteristic of the pedal EB401	0 4		4	4	4
F-100	Stitch number softstart	000 254		002	002	002
F-110	Positioning speed n1	070 390	min-1	200	200	200
F-111	Maximum speed n2- (setting range)	n2_ 9900	min-1	2200	1800	1800
F-115	Softstart speed n6	0070 1500	min-1	0500	0500	0500
F-121	Lower limit of the n-max setting range	0200 n2-	min-1	0200	0200	0200
F-134	Softstart OFF/ON	0 1		0	0	0
F-153	Holding force during machine standstill	00 50		05	05	05

		Machine class				
		Setting range	Unit	Preset at mode 56	443-2	443-2F
F-161	Direction of rotation of the motor	0 1		0	0	0
F-180	Number of turn-back steps	000 359	Degree	040	040	040
F-181	Switch delay for turn back	000 990	ms	200	200	200
F-182	Turn back OFF/ON	0 1		0	0	0
F-207	Braking effect when changing the set-point <= 4 steps (indicated valus only with transmission ratio 1:1)	00 55		15	15	15
F-208	Braking effect when changing the set-point >= 5 steps (indicated valus only with transmission ratio 1:1)	00 55		20	20	20
F-219	Positioning force when stopping the drive	00 55		04	04	04
F-220	Accelerating power of the drive (indicated valus only with transmission ratio 1:1)	00 55		20	35	35
F-234	Restarting after activated run inhibition	0 1		1	0	1
F-240	Selecting the input function In.1	00 47		00	00	00
F-270	Selection o9f the position sensors	0 6		0	0	0
F-272	Transmission motor shaft to machine shaft	0150 9999		1000	1000	1000
F-280	Delay time Thread trimmer (M1)	0000 5000	ms	0100	0000	1000
F-281	On-time Thread trimmer (M1)	0000 5000	ms	0180	0180	0180

		Machine class				
		Setting range	Unit	Preset at mode 56	443-2	443-2F
F-284	Delay time Output M3	0000 5000	ms	0000	0200	0200
F-285	On-time Output M3	0000 5000	ms	0300	0300	0300
F-288	Delay time till lifting On	0000 5000	ms	0200	0200	0200
Stand: 11.01.2021 - PT_AB425S_443-2_210111						



# Und wir können noch mehr für Sie tun!

Unser Lieferprogramm bietet für jede Branche und jegliche Anforderung genau die richtige Problemlösung.

## *And we can do a lot more for you!*

*Our range offers the correct problem solution for every branch and for all requirements.*

### ■ Für die Bekleidungsindustrie:

Ein- und Zweifaden-Hochleistungs-Saummaschinen

Doppelblindstich-Saummaschinen

Zweifaden-Blindstich-Staffiermaschinen

Roll- und Flachpikiermaschinen

Pikier-Automat

und

weitere Spezial-Nähmaschinen

### ■ *For the clothing industry:*

*Single and two thread high performance hemming machines*

*Bluff edge hemming machines*

*Two thread blind stitch felling machines*

*Roll and flat padding machines*

*Automatic lapel padding machine*

*and other special sewing machines*

### ■ Für die Schuhverarbeitung:

Einfaden-Überwendlichmaschinen mit und ohne Differentialtransport

### ■ *For the shoe industry:*

*Single-thread overseaming machines with and without differential feed*

### ■ Für Kürschnereien und Pelzkonfektion:

Pelzschnellnäher

### ■ *For the fur industry:*

*High-speed fur sewing machines*

### ■ Für Heimtextilien:

Ein- und Zweifaden-Blindstichmaschinen

### ■ *For the home textiles industry:*

*Single and two thread blind stitch machines*

### ■ Für die Polsterverarbeitung:

Ein- und Zweifaden-Überwendlichmaschinen

Ein- und Zweifaden-Blindstichmaschinen

### ■ *For the upholstery industry:*

*Single and two thread overseaming machines*

*Single and two thread blind stitch machines*

### ■ Für die Konfektion technischer Textilien:

Ein- und Zweifaden-Überwendlichmaschinen

### ■ *For the processing of technical textiles:*

*Single and two thread overseaming machines*

## Noch Fragen?

Dann rufen Sie uns an, schreiben Sie uns oder kommen Sie einfach bei uns vorbei.

Sie können jederzeit weitere Informationen über unsere Produkte anfordern oder die Strobel-Nähmaschinen in unserem Ausstellungsraum live erleben. Wir freuen uns auf Sie!

## *Any further questions?*

*Then phone, write or simply come and see us. You can have further information about our products at any time, or experience the Strobel machines live in our show room. We're looking forward to meeting you!*

***STROBEL***

**Spezialmaschinen GmbH**

Postfach 1242  
82168 Puchheim  
Boschstraße 16  
82178 Puchheim  
DEUTSCHLAND

[www.strobel.biz](http://www.strobel.biz)  
Telefon: +49 89 80096-0  
Telefax: +49 89 80096-190