

Teileliste und Naehinrichtungen
Parts List and Sewing Equipment

869

DÜRKOPP ADLER AG

Postfach 17 03 51, D-33703 Bielefeld • Potsdamer Str. 190, D-33719 Bielefeld
Telefon +49 (0) 5 21/ 9 25-00 • Telefax +49 (0) 5 21/ 9 25 24 35 • www.duerkopp-adler.com

Ausgabe / Edition: 10/2013	Aenderungsindex Rev. index: 05.0	Printed in Czech Republic	Teile-Nr./Part.-No.: 0791 869801
--------------------------------------	--	---------------------------	--

Alle Rechte vorbehalten.

Eigentum der Dürkopp Adler AG und urheberrechtlich geschützt. Jede, auch auszugsweise Wiederverwendung dieser Inhalte ist ohne vorheriges schriftliches Einverständnis der Dürkopp Adler AG verboten.

All rights reserved.

Property of Dürkopp Adler AG and copyrighted. Reproduction or publication of the content in any manner, even in extracts, without prior written permission of Dürkopp Adler AG, is prohibited.

Copyright © Dürkopp Adler AG - 2013

Inhaltsverzeichnis	Tafel / Table	Contents
Armwelle	1	Upper shaft
Antrieb Arm- und Unterwelle, Rastkupplung	2	Upper and bottom shaft drive, Safety clutch
Fadenhebel	3	Thread lever
Nadeltransport	4	Needle feed
Alternierender Obertransport mech., Fussfuehrung	5	Alternating foot top feed mech., Foot guide
Antrieb Untertransport	6, 7	Bottom feed drive
Fusslueftung Handhebel	8	Presser foot lift hand lever
Fusslueftung Kniehebel	9	Presser foot lift knee lever
Fusslueftung pneu.	10	Presser foot lift pneu.
Hubverstellung	11	Skipping foot lift pneumatic
Greifer mit Spule	12	Hook with bobbin
Greiferlager rechts, links	13	Hook case right, left
Fadenabschneider rechts, links	14	Thread trimmer right, left
Spuler	15	Winder
Spannungsplatte Einnadel mech.	16	Tension plate 1 needle mech.
Spannungsplatte Einnadel pneu.	17	Tension plate 1 needle pneu.
Spannungsplatte Zweinadel mech.	18	Tension plate 2 needles mech.
Spannungsplatte Zweinadel pneu.	19	Tension plate 2 needles pneu.
Stichverstellung 1 Stichlaenge, Stichverstellung 2 Stichlaengen	20	Stitch adjustment 1 stitch length, Stitch adjustment 2 stitch lengths
Verriegelung mech., pneu.	21	Backtacking mech., pneu.
Magnetventileinheit	22	Solenoid valve unit
Magnetventileinheit, Taster	23	Solenoid valve unit, Push-buttons
Zentralschmierung, Oelstandanzeige	24	Central lubrication, Maintenance indicator
Arm, Fadenfuehrung, Integr. Diodennaehleuchte	25	Arm, Thread guide, Sewing light LEDs
Armdeckel ECO	26	Arm cover ECO
Armdeckel BASIS	27	Arm cover BASIS
Socle	28	Socket
Unterarm Einnadel	29	Bottom arm 1 needle
Unterarm Zweinadel	30	Bottom arm 2 needles
Naehleuchte Halogen, Teilesatz	31	Sewing lamp halogen, Part set
Teilesatz fuer DAC ECO	32	Part set for DAC ECO
Teilesatz fuer DAC Classic	33	Part set for DAC Classic
Naehantrieb EFKA DC1550/DA321G, Teilesatz DC1550/DA321G,	34	Ministop EFKA DC1550/321G, Part set DC1550/DA321G,
Bedienfeld, USB Memory Stick		Control panel, USB memory key
Gestell	35 - 37	Stand
Wartungseinheit	38	Maintenance unit

Inhaltsverzeichnis	Tafel / Table	Contents
Beipack	39, 40	Accessories
Elektropneum. Nadelkuehlung,	41	Electropneum. needle cooling,
Rollenanschlag		Roller stop
Diodennaehleuchte	42	Sewing lamp LEDs
Netzteil		Power supply
Werkzeug M-Type		Tool kits M-Type
Fusslueftung Pedal	43	Foot lift pedal
Fusslueftung pneu.		Foot lift pneu.
Fusslueftung el. pneu.		Foot lift el. pneu.
Verriegelung mech.		Backtacking mech.
Index		Index
Naeheinrichtungen		Sewing equipment
Bauschaltplan		Wiring diagram
Pneu. Geraeteplan		Pneumatic circuit plan

869



Einnadel-Maschine
single needle machine



Zweinadel-Maschine
two needle machine

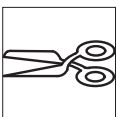

mit Fadenabschneider
with thread trimmer



ohne Fadenabschneider
without thread trimmer



kleben/stick

N

nicht einzeln lieferbar/not available as separate part

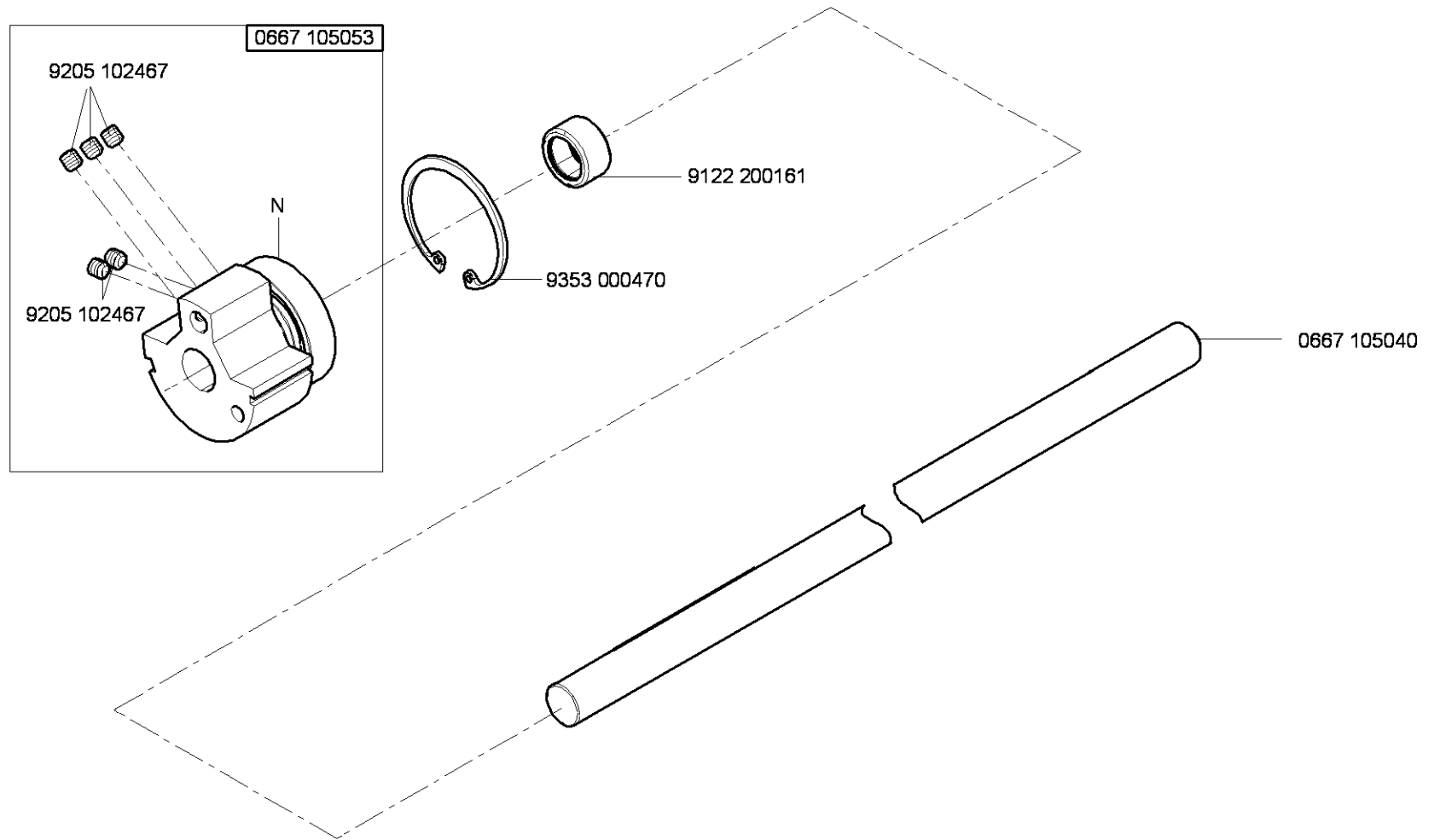

N - nicht als Einzelteil lieferbar
not available as separate part

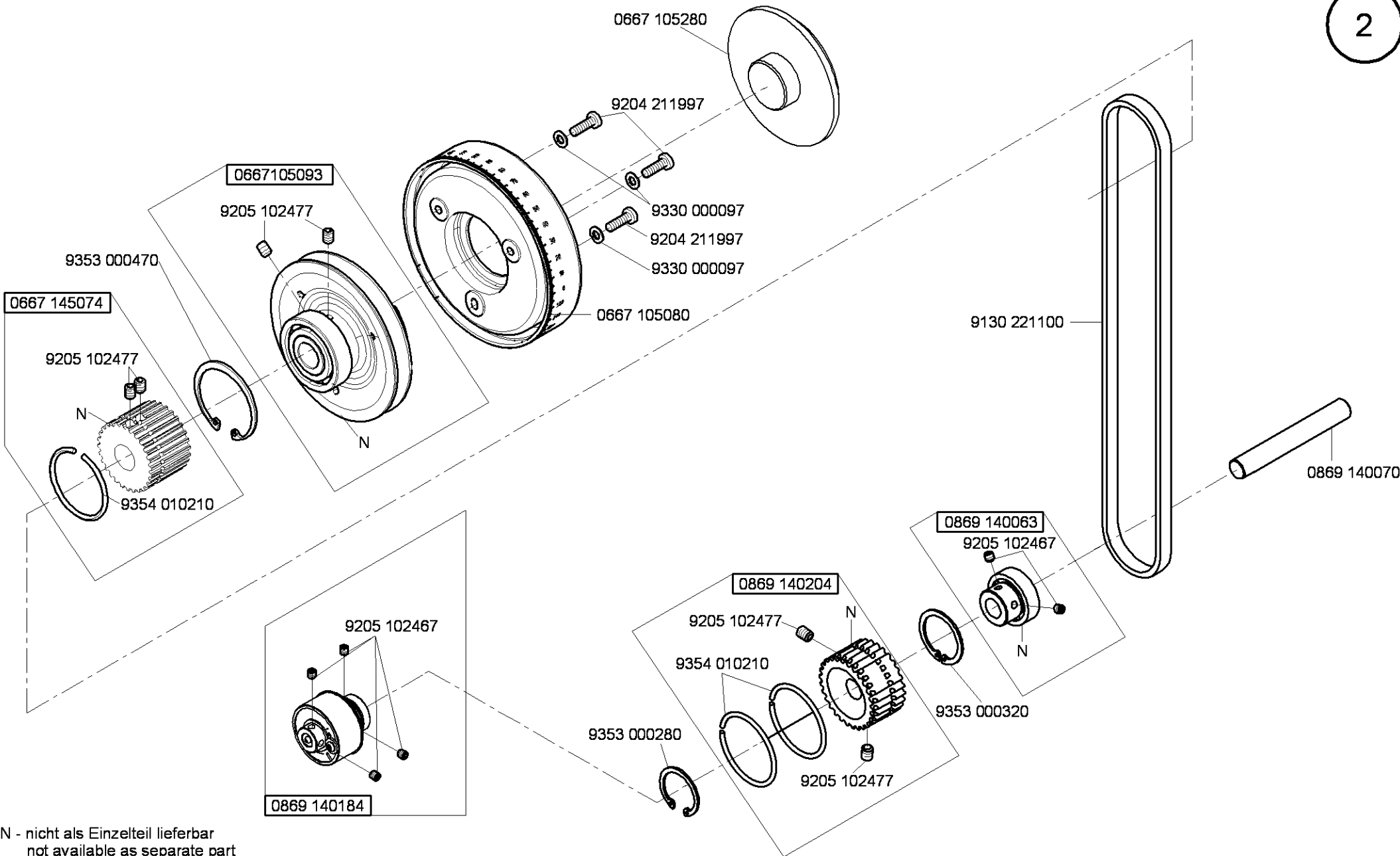

N - nicht als Einzelteil lieferbar
not available as separate part

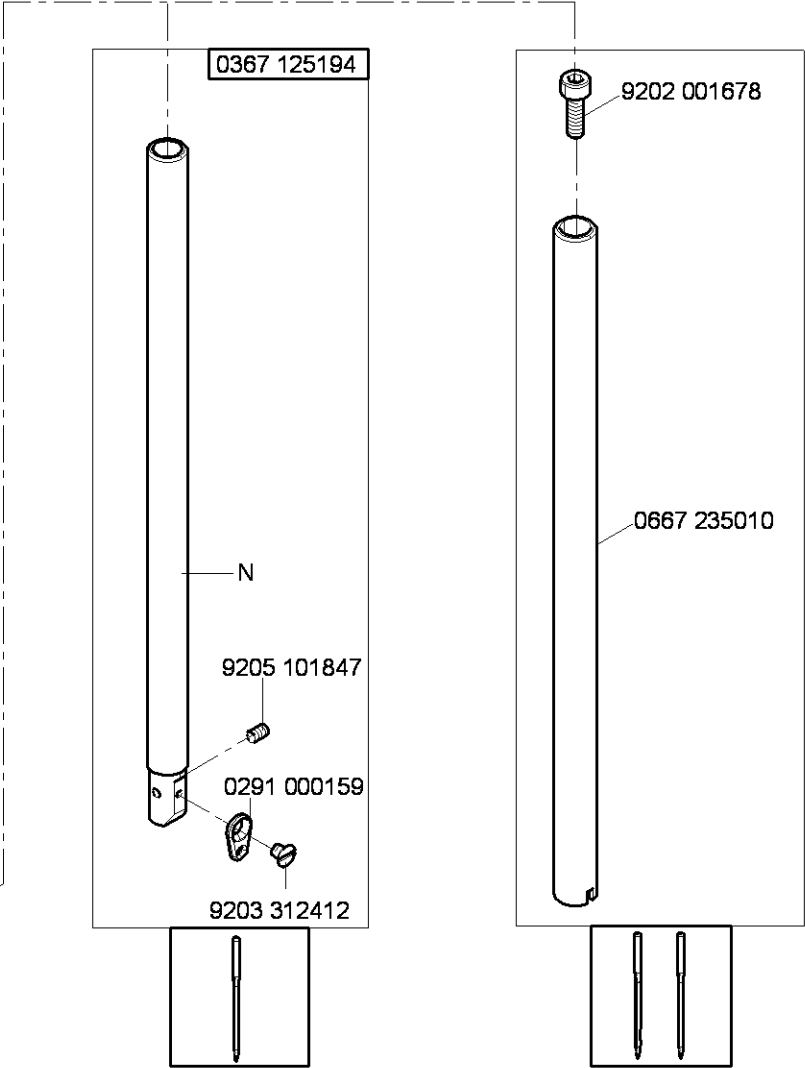
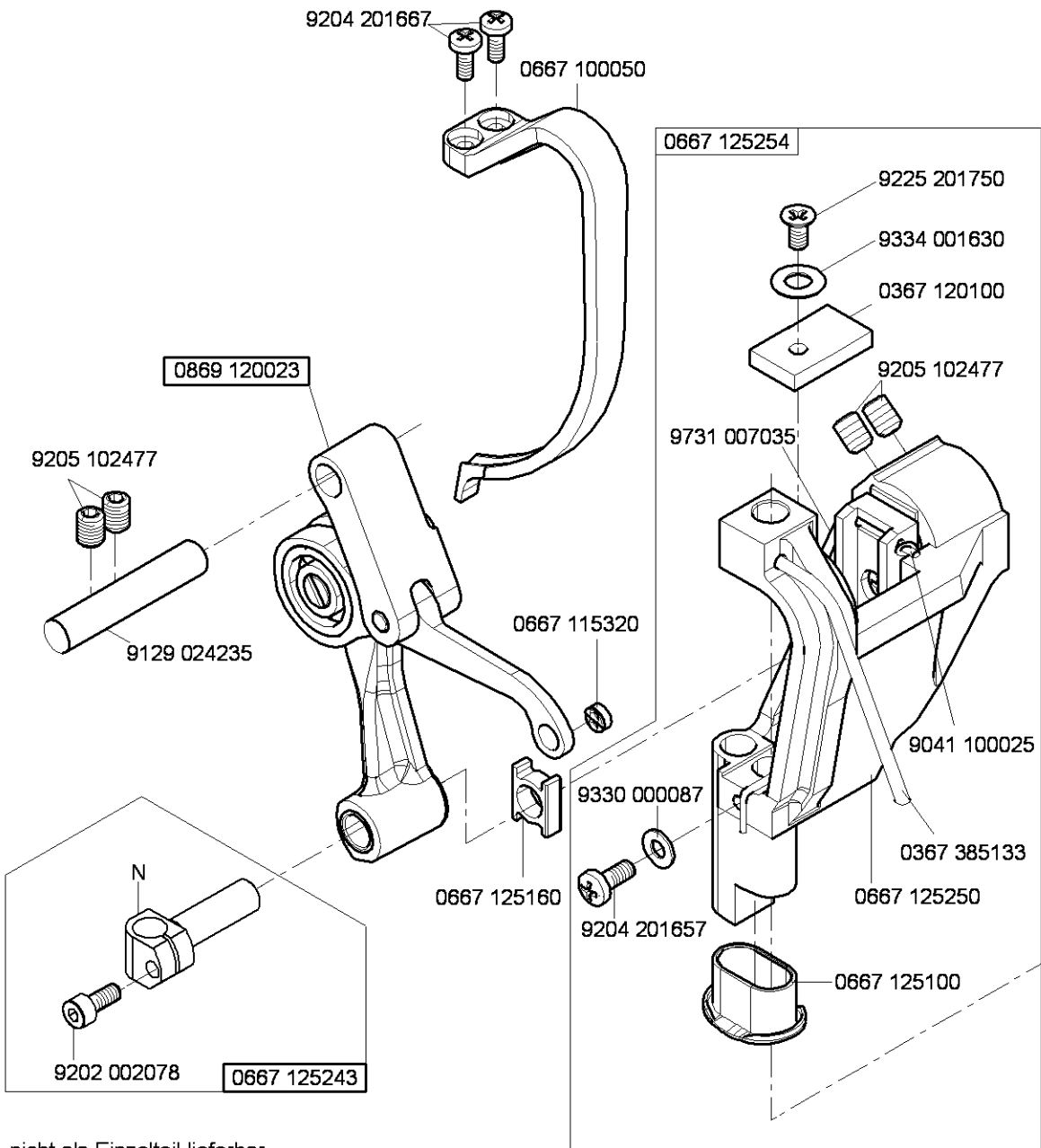

N - nicht als Einzelteil lieferbar
not available as separate part

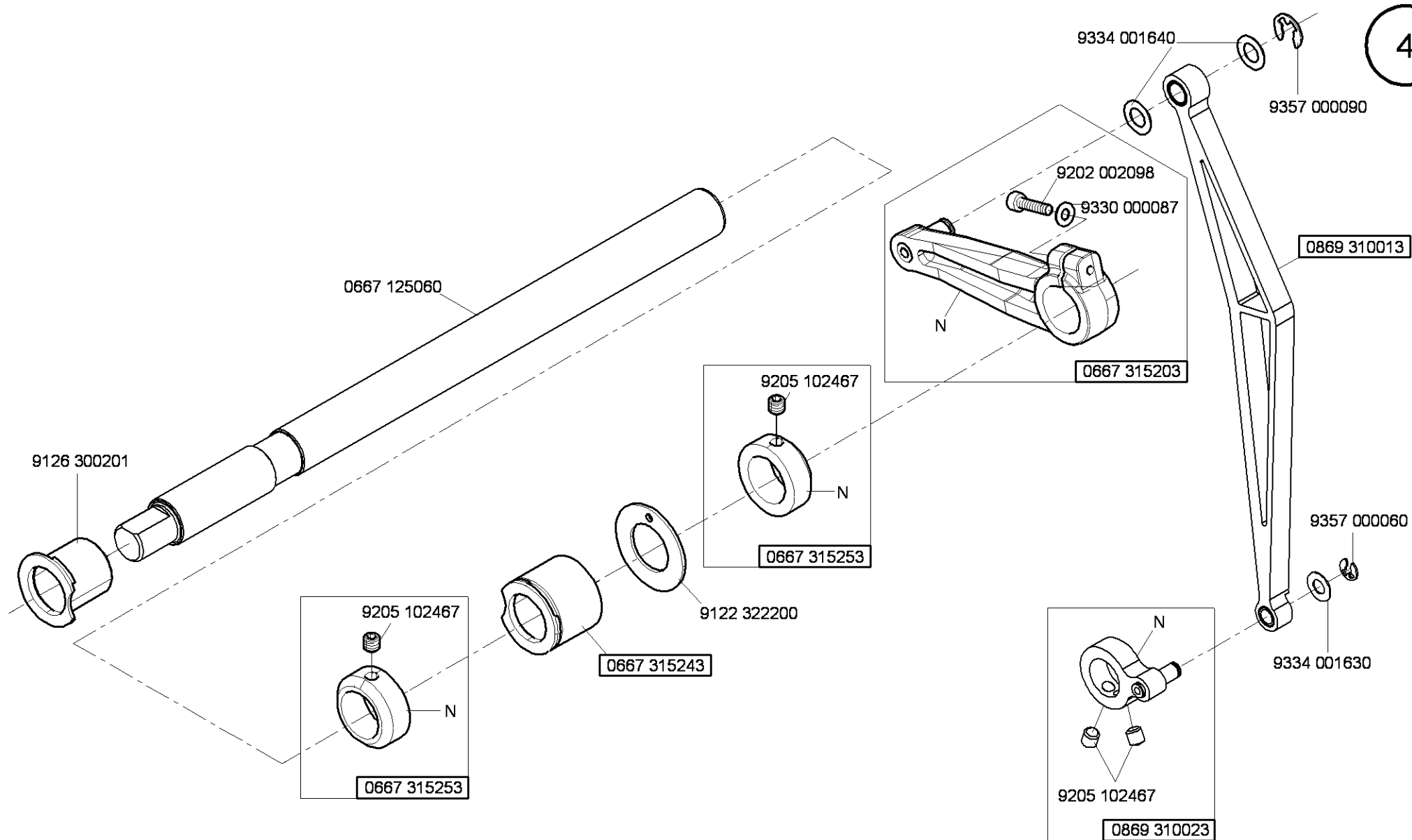

N - nicht als Einzelteil lieferbar
not available as separate part

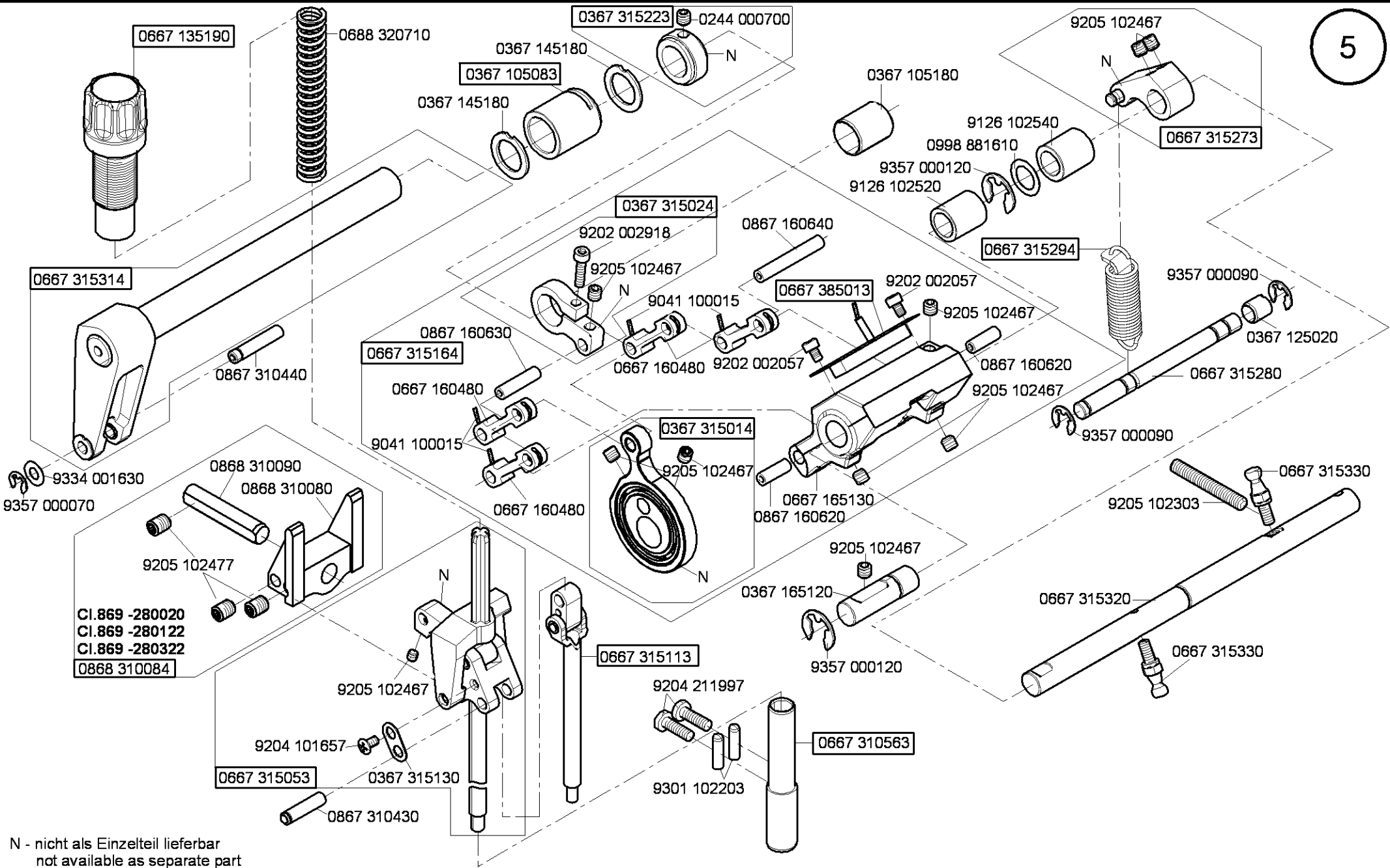

N - nicht als Einzelteil lieferbar
 not available as separate part

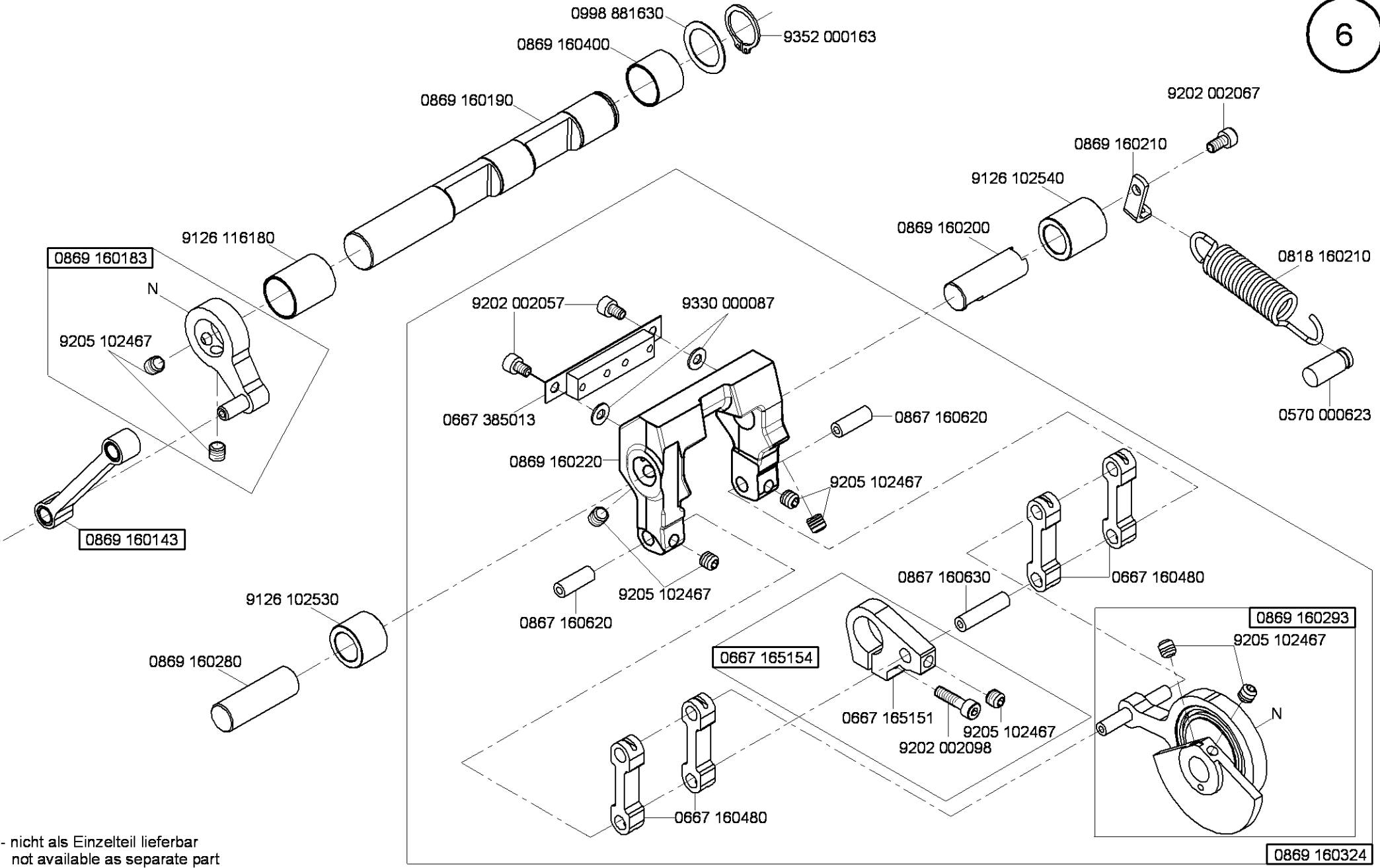

N - nicht als Einzelteil lieferbar
not available as separate part

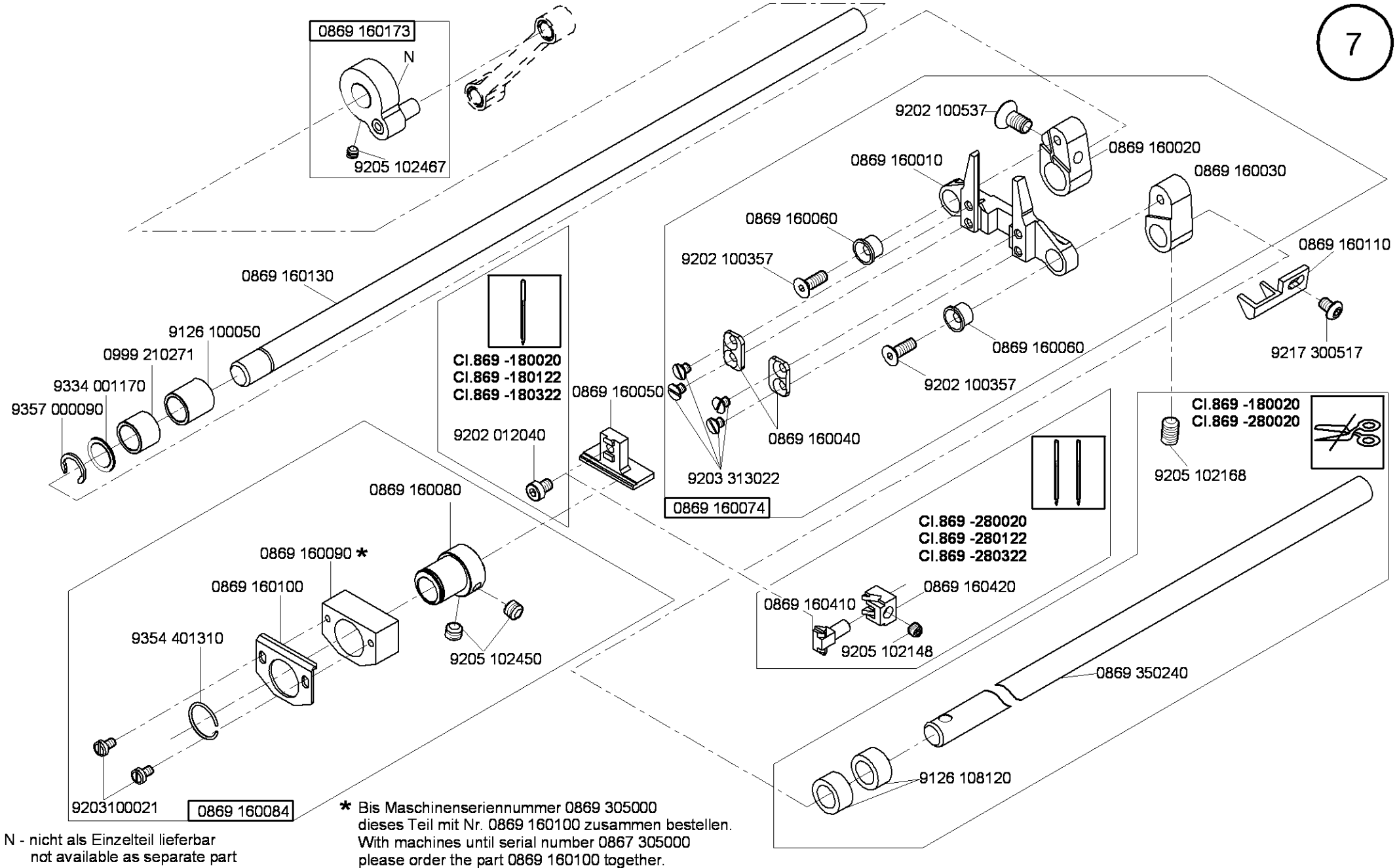

N - nicht als Einzelteil lieferbar
not available as separate part

* Bis Maschinenseriennummer 0869 305000
dieses Teil mit Nr. 0869 160100 zusammen bestellen.
With machines until serial number 0867 305000
please order the part 0869 160100 together.

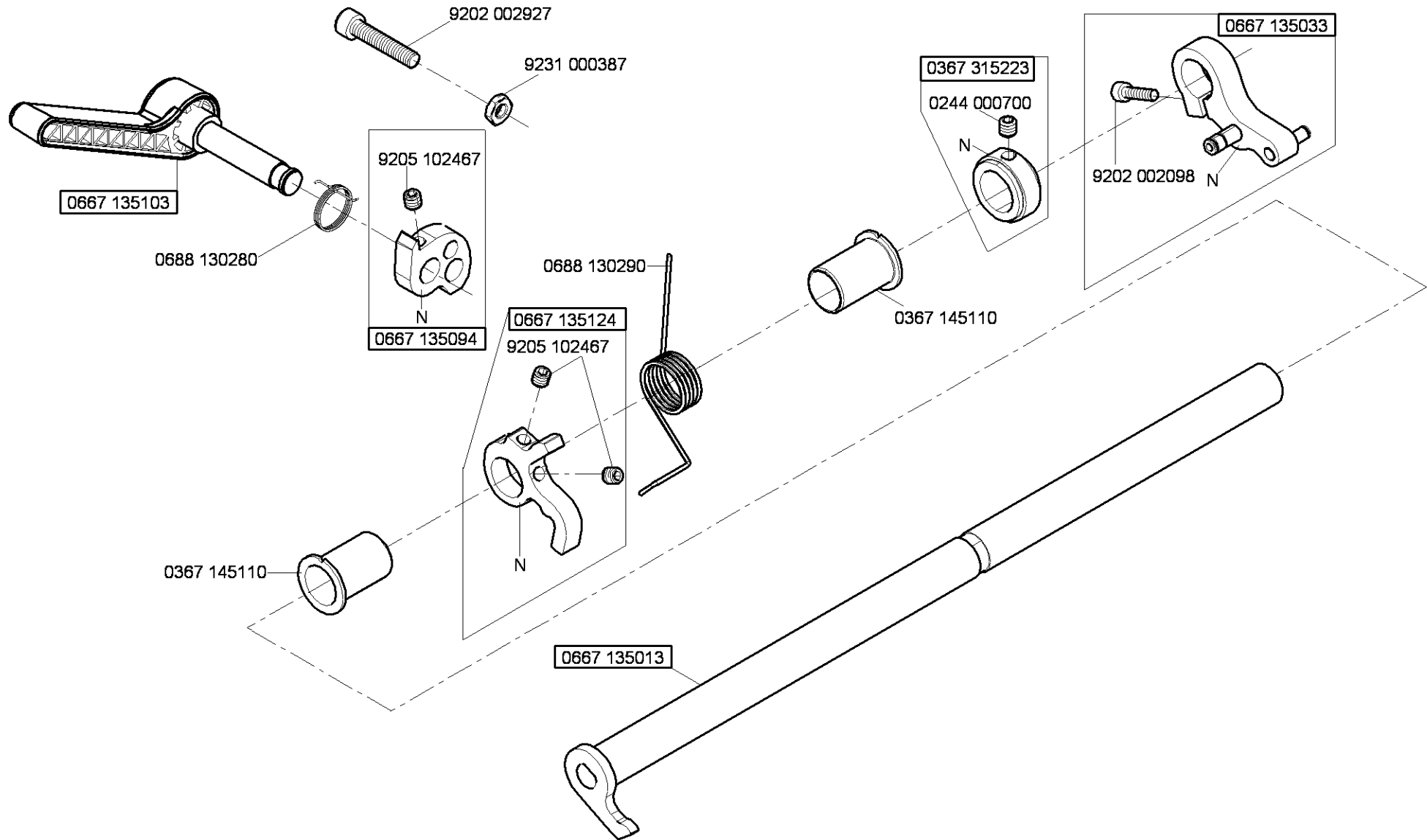

N - nicht als Einzelteil lieferbar
not available as separate part

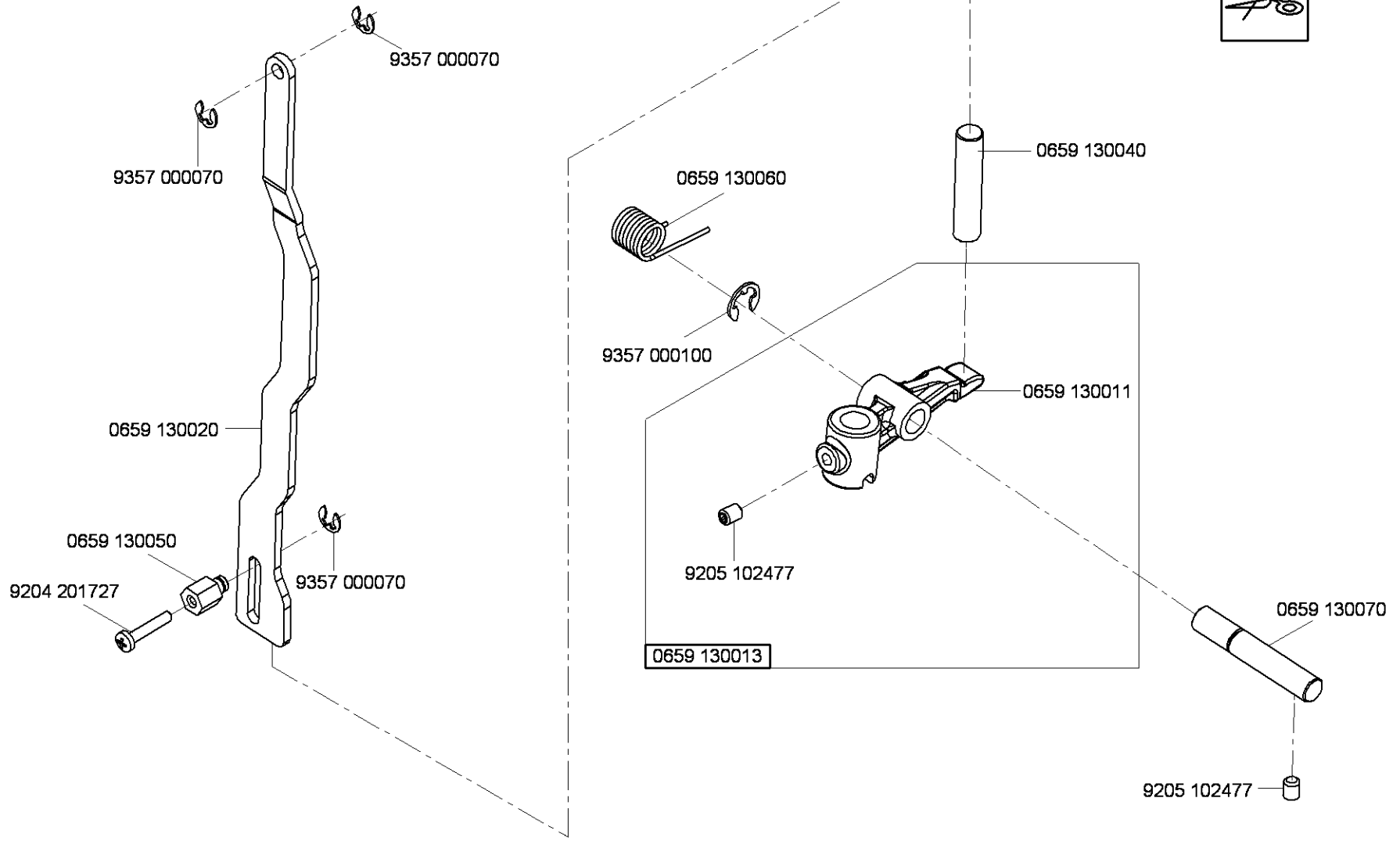
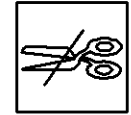

N - nicht als Einzelteil lieferbar
not available as separate part

CI.869 -180122
CI.869 -180132
CI.869 -280122
CI.869 -280322

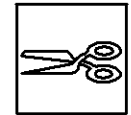

9357 000070

9700 100103

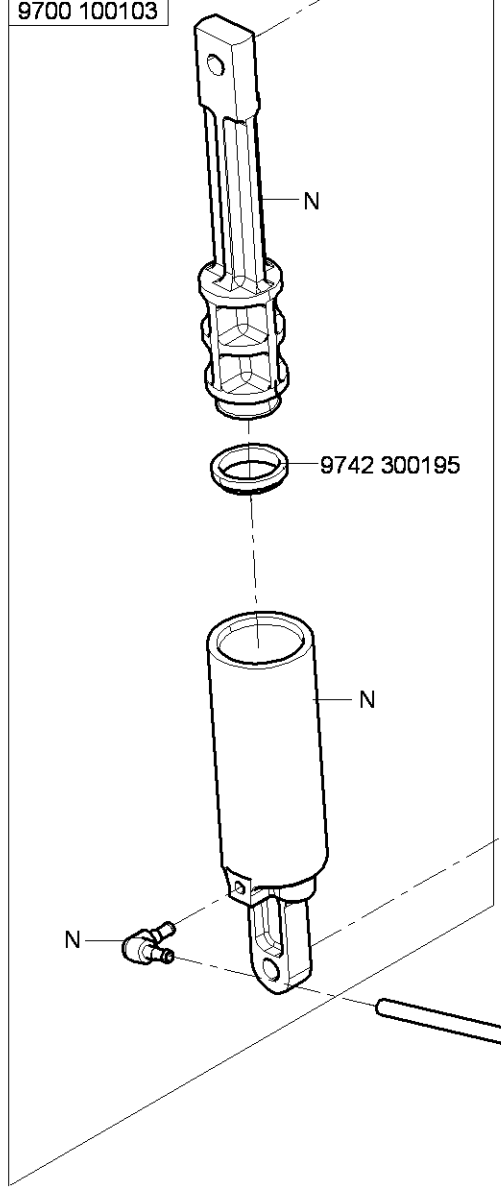

N

9742 300195

N

0367 135200

N

9731 005004

0667 135204

N - nicht als Einzelteil lieferbar
not available as separate part

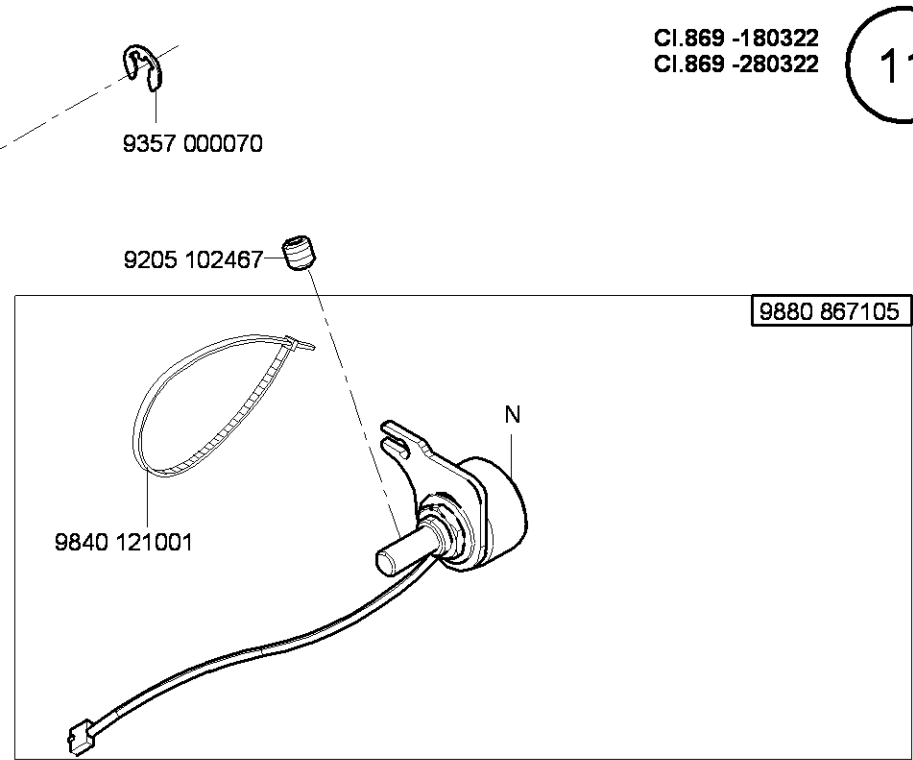
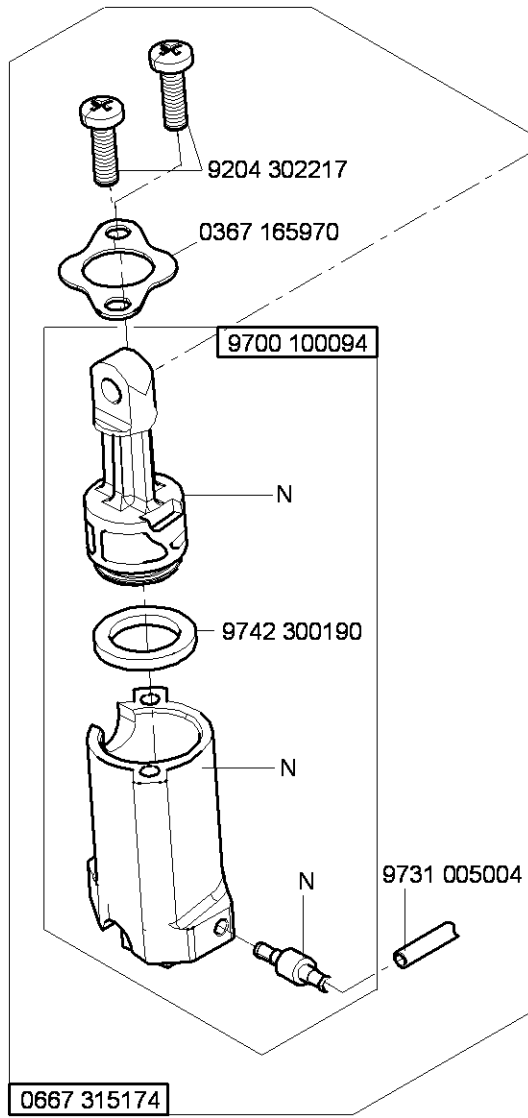
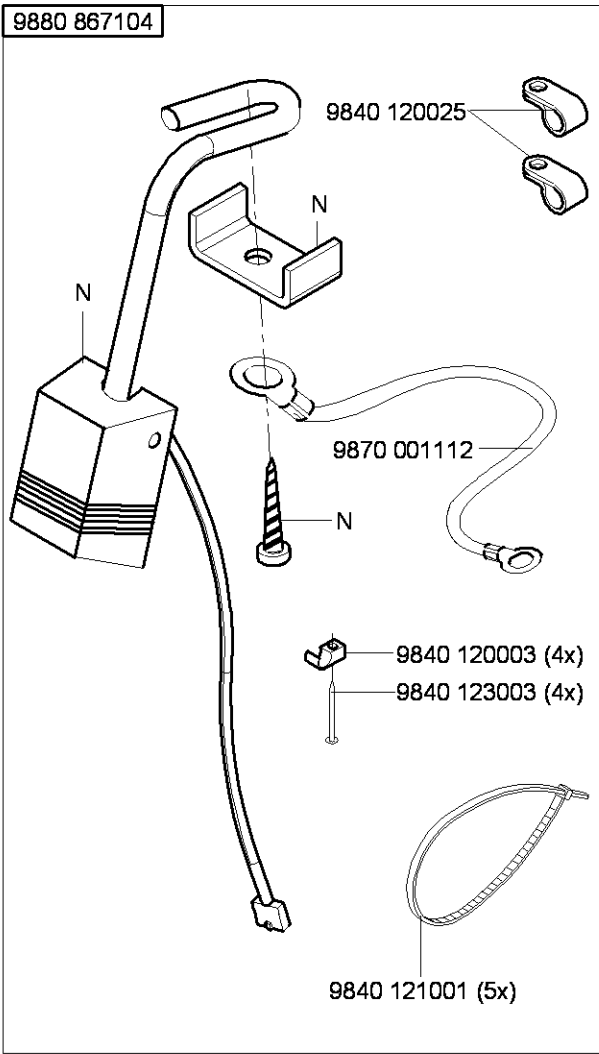

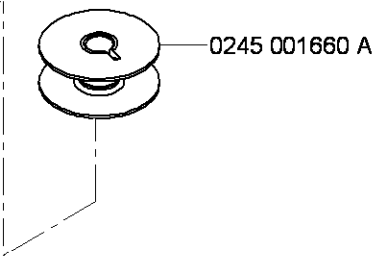
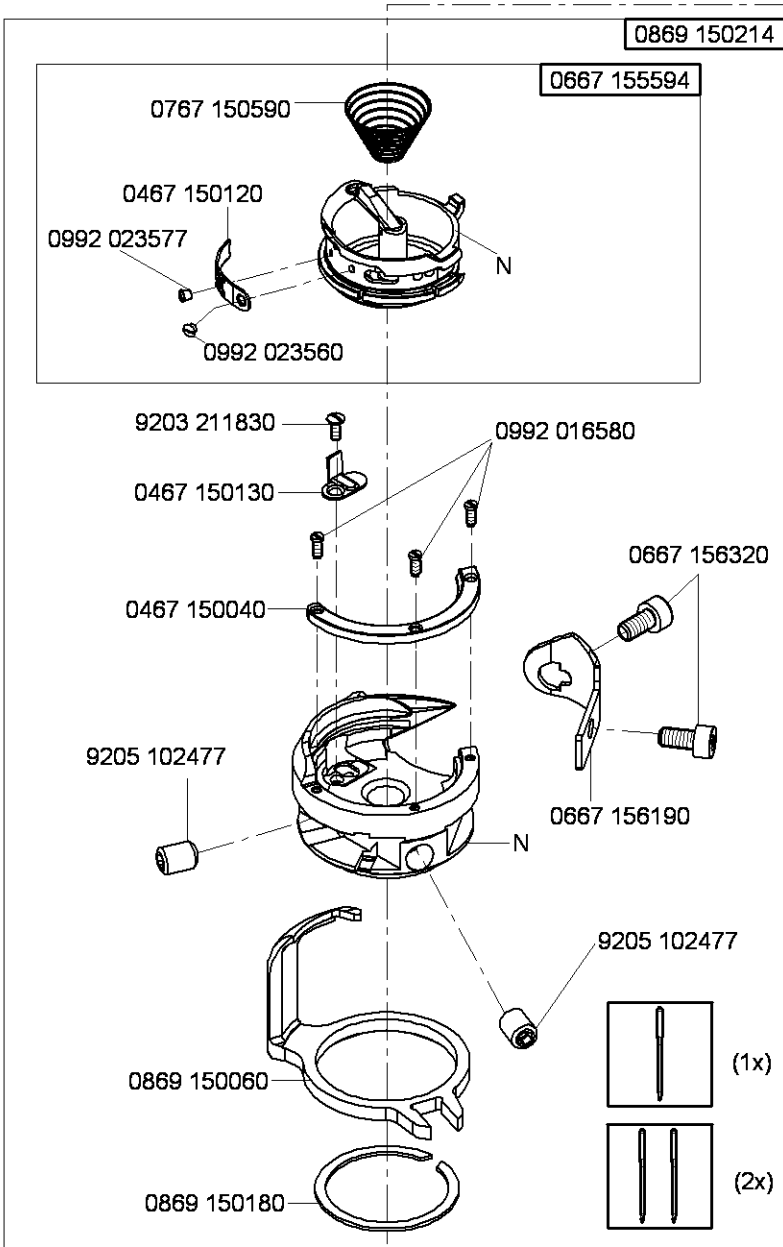

N - nicht als Einzelteil lieferbar
not available as separate part

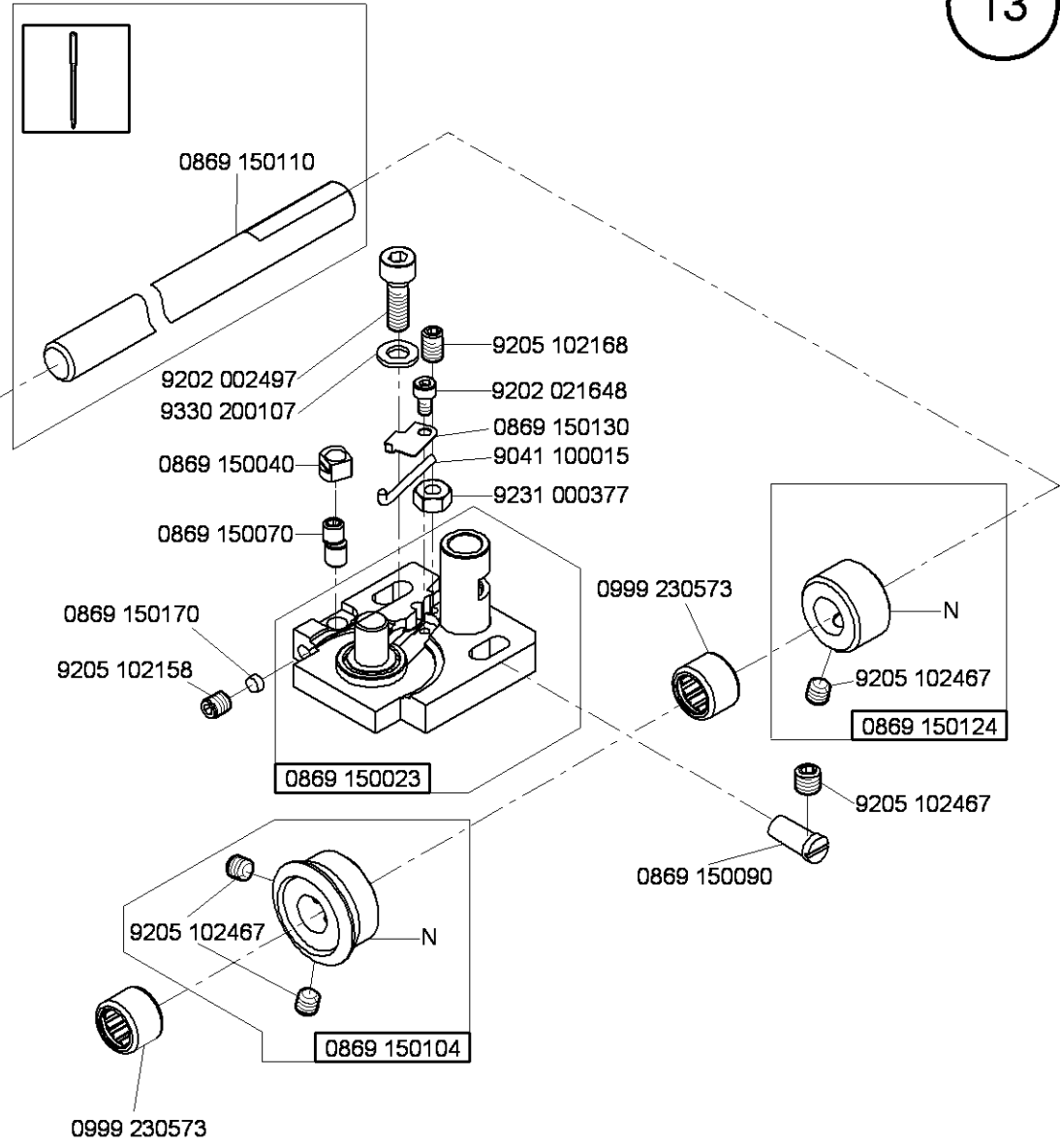
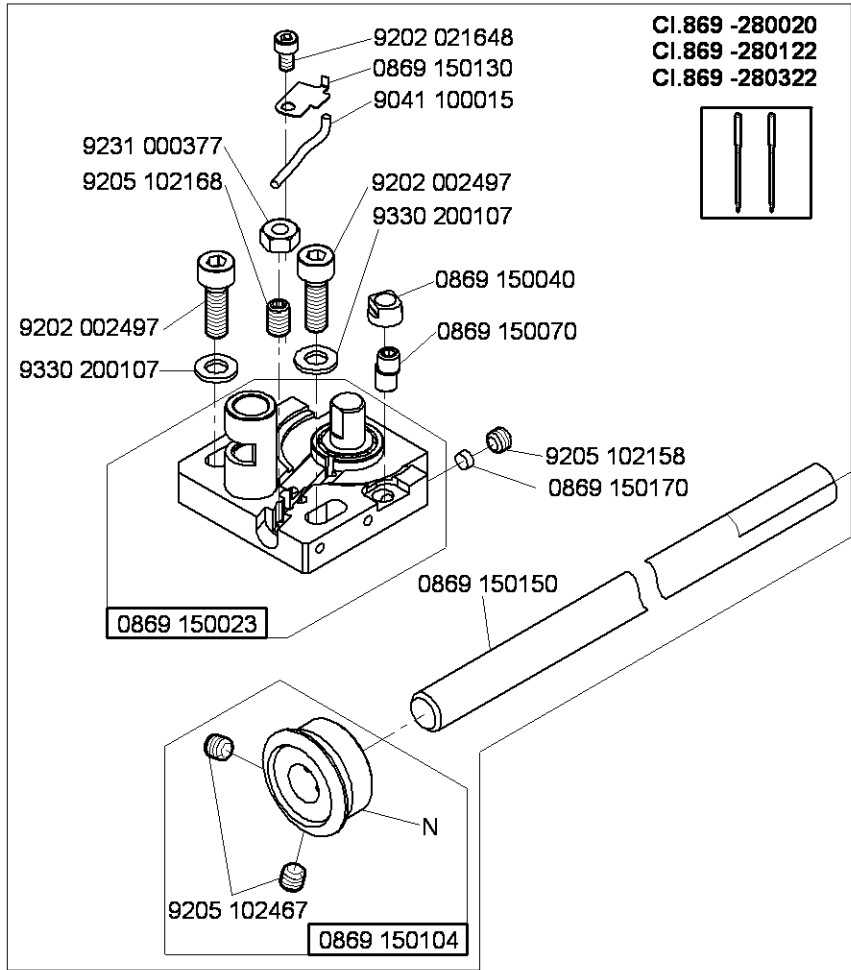

N - nicht als Einzelteil lieferbar
not available as separate part

CI.869 -180122
CI.869 -180322
CI.869 -280122
CI.869 -280322

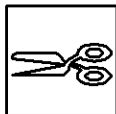

0869 350313 **Ab 02.10**

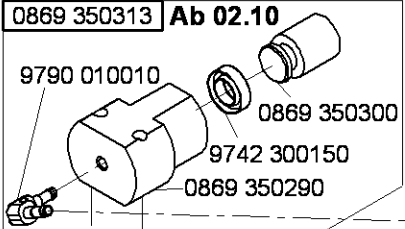

0869 350033 **Bis 01.10**

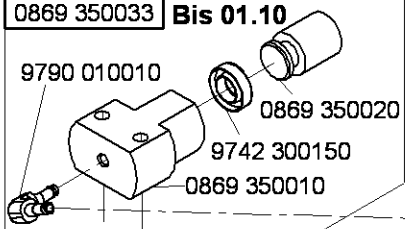

9205 101868

9225 201240

0869 350134

0869 350143

0869 350230

0688 350160

0869 350220

9203 361828

0869 350110

0688 320630

9202 022078

0869 350150

0869 350250

9201 111257

9330 000067

9205 102158

9334 001150

0869 350123

0869 350100

9126 108120

9205 102158

0869 350214

9126 108120

9205 102148

0869 350090

9205 102158

9205 102158

9731 005004

0869 350280

9202 150317

0869 350080

9202 002117

9330 200097

9202 002057

9731 005004

0869 350060

0869 350044

0869 350050

0869 350040

9205 102467

9202 022078

0869 350150



0869 350134

0869 350220

0869 350143

9203 361828

0869 350230

0688 350160

0869 350160

0869 350250

9330 000067

9201 111257

0688 320630

0869 350110

0869 350123

0869 350180

9205 101868

9225 201240

9205 102148

CI.869 -280122
CI.869 -280322

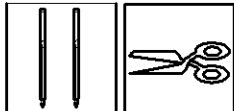

CI.869 -180122
CI.869 -180322



0869 350070

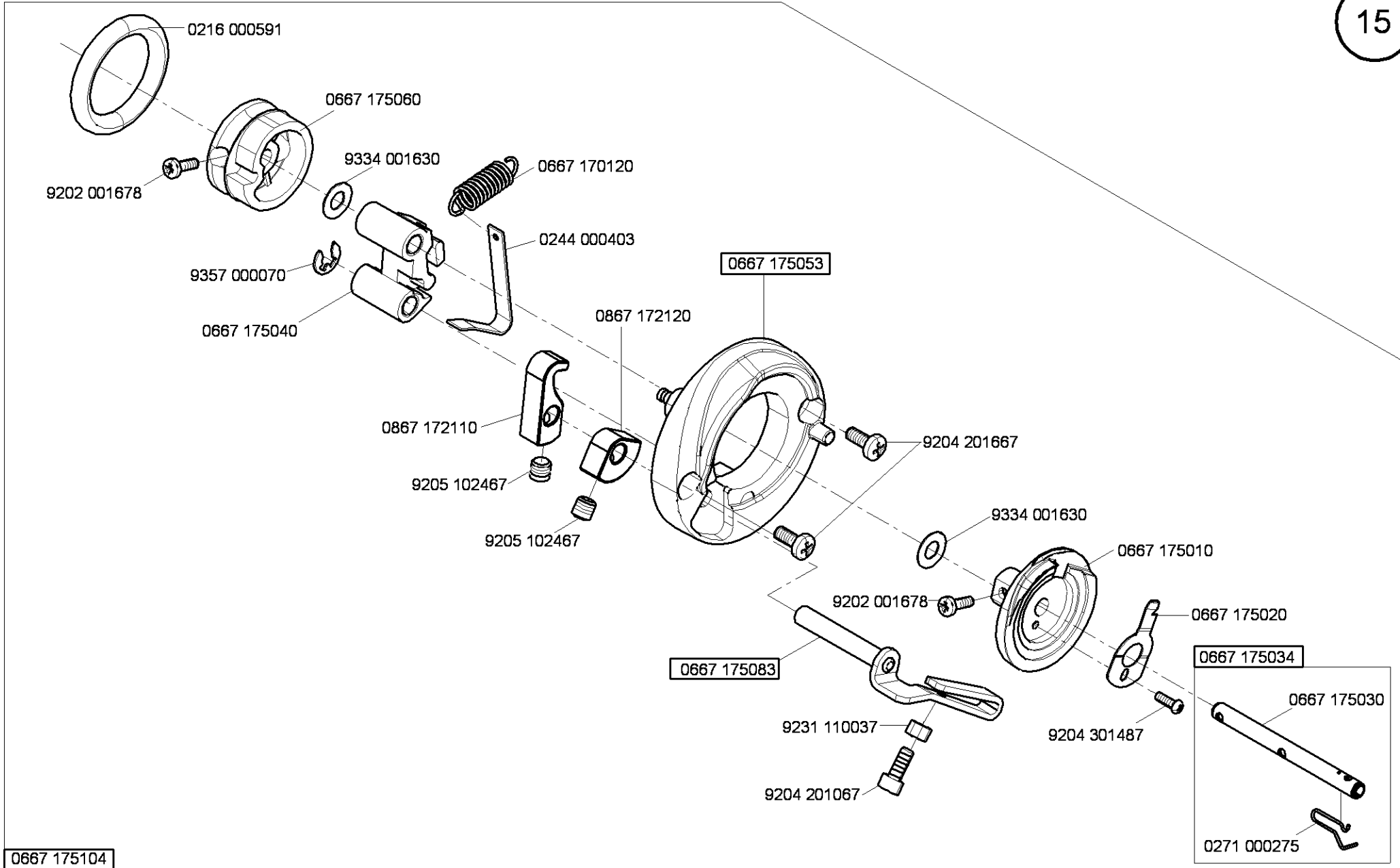

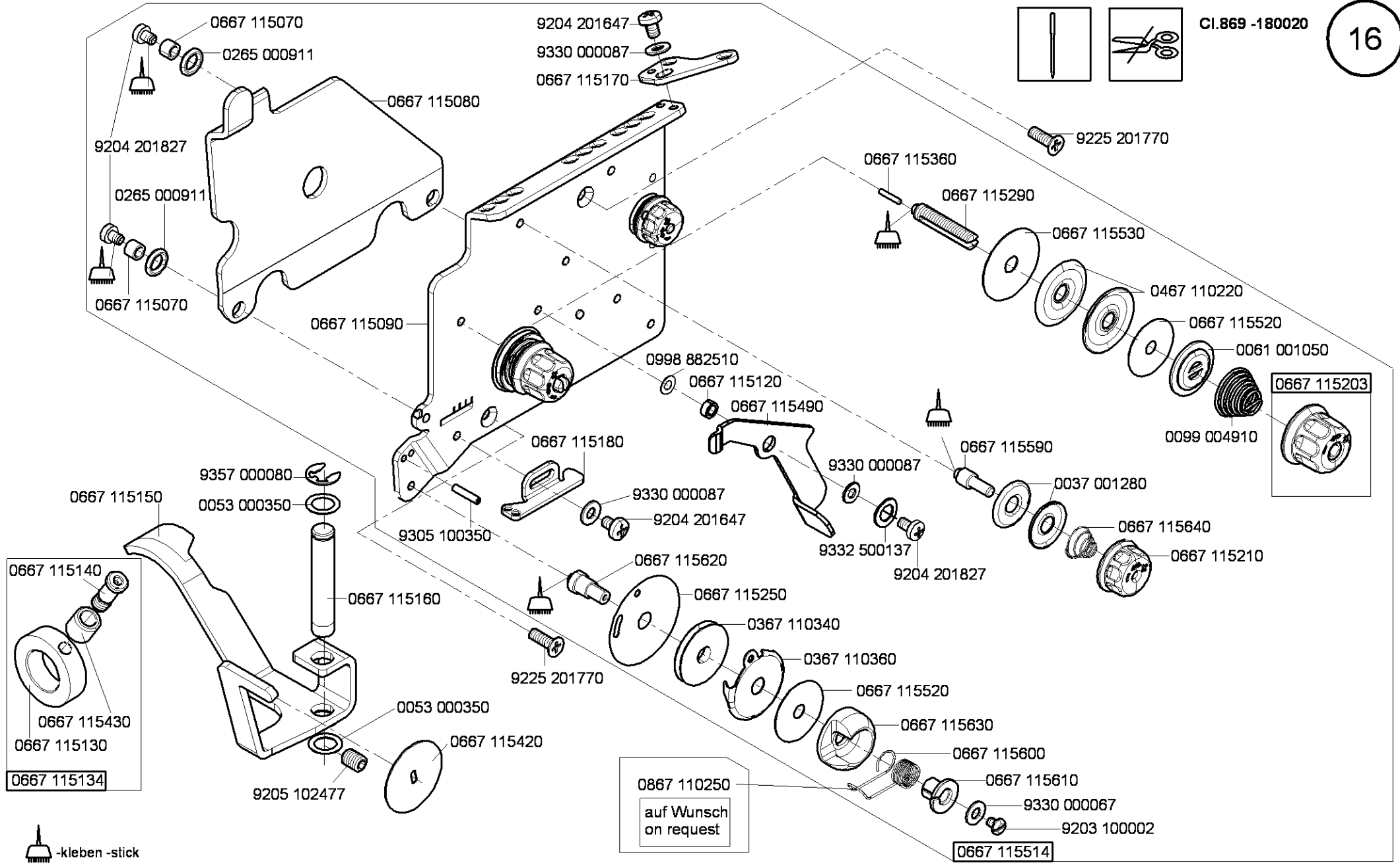

-kleben -stick

0867 110250
auf Wunsch
on request

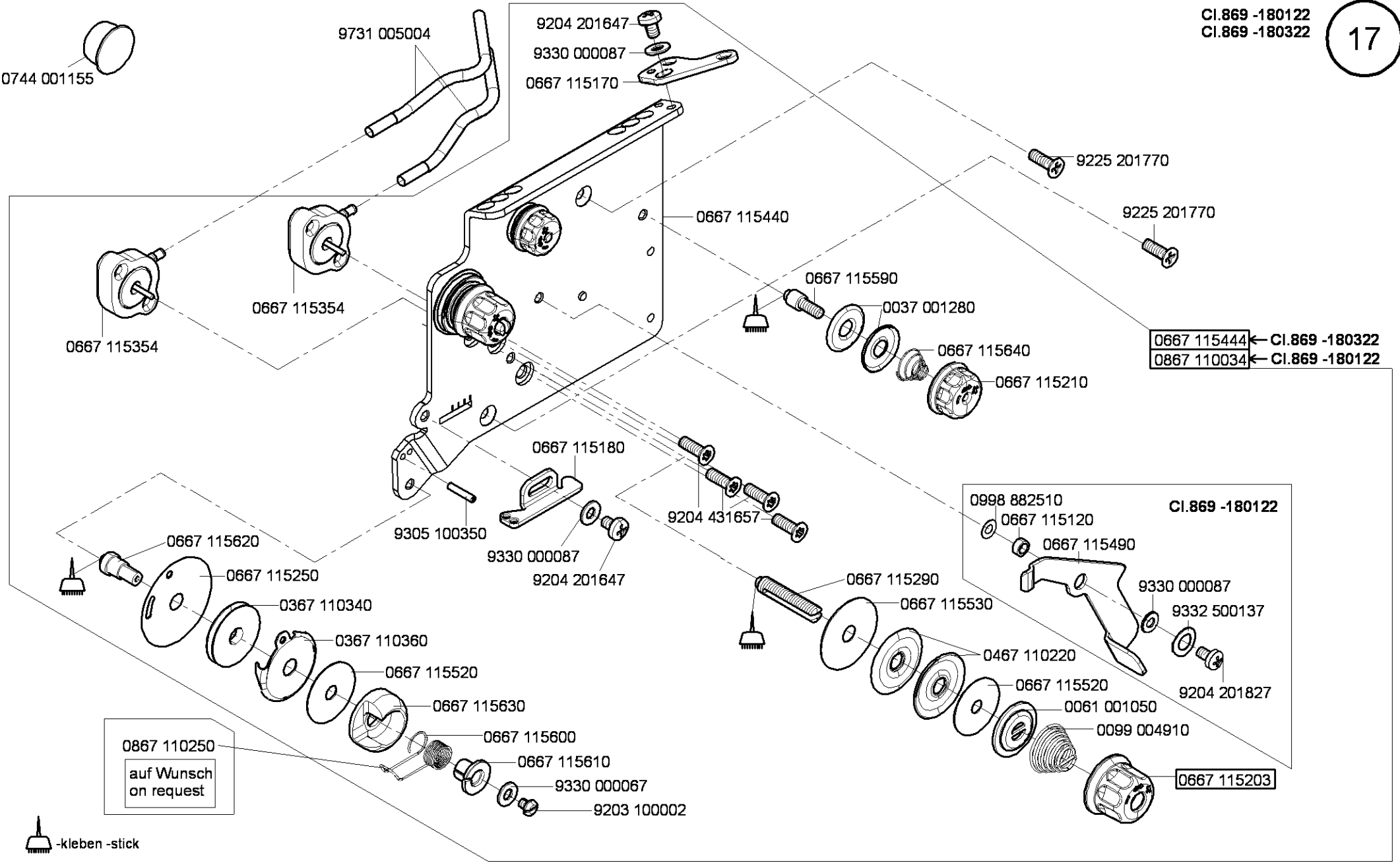

 -kleben -stick

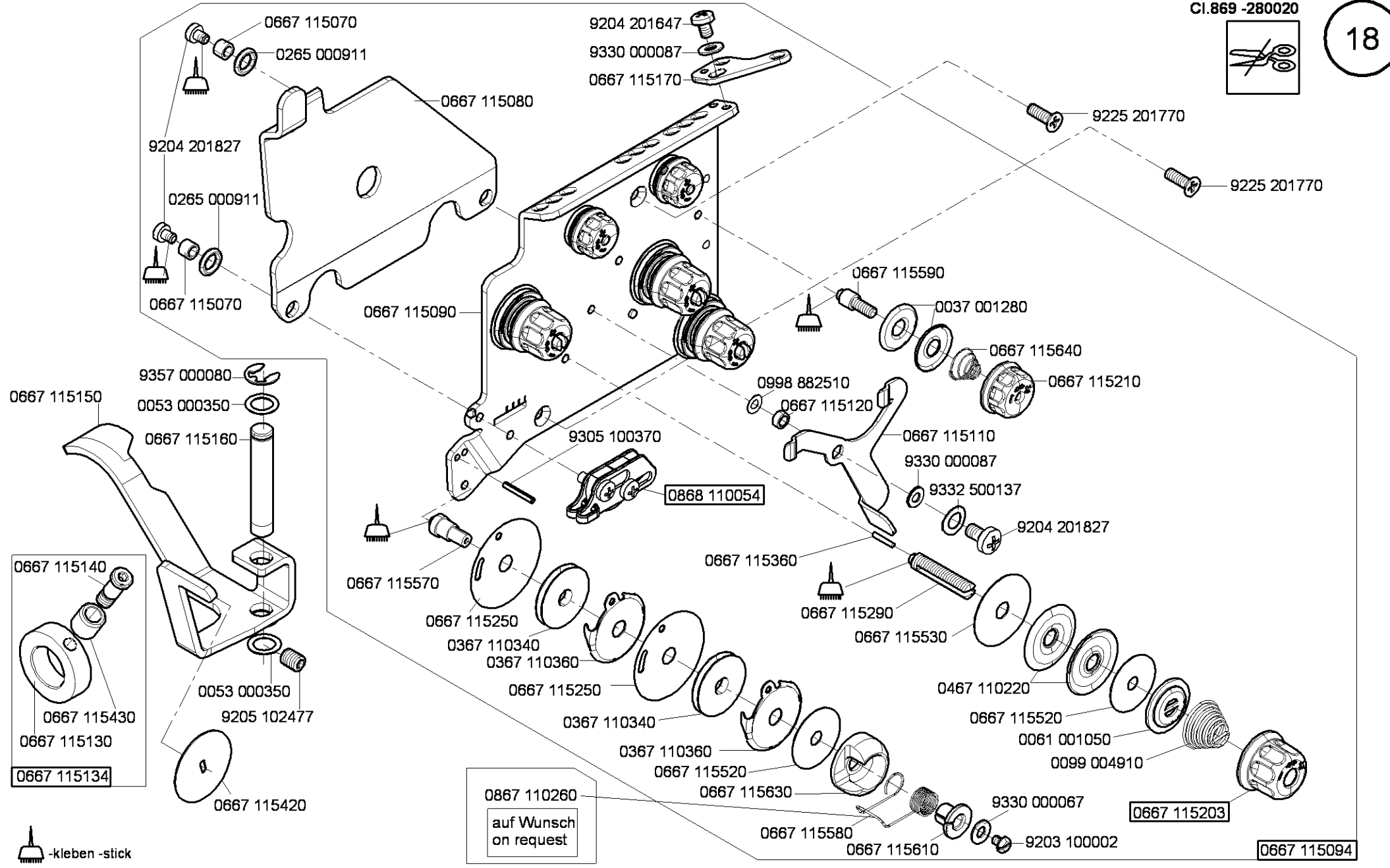
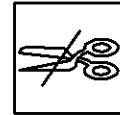

0867 110260
auf Wunsch
on request

-kleben -stick

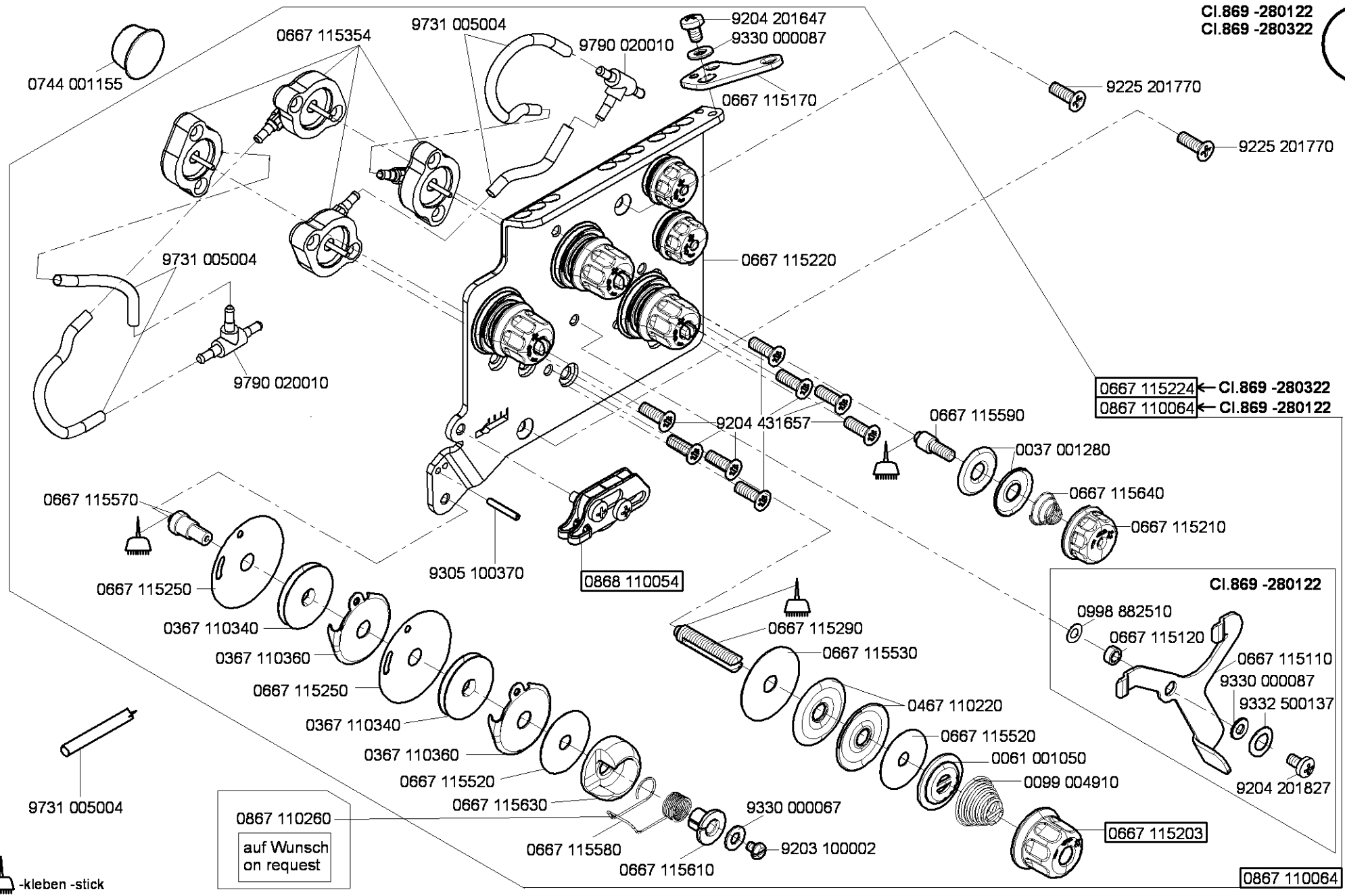

0867 110260
auf Wunsch
on request

-kleben -stick

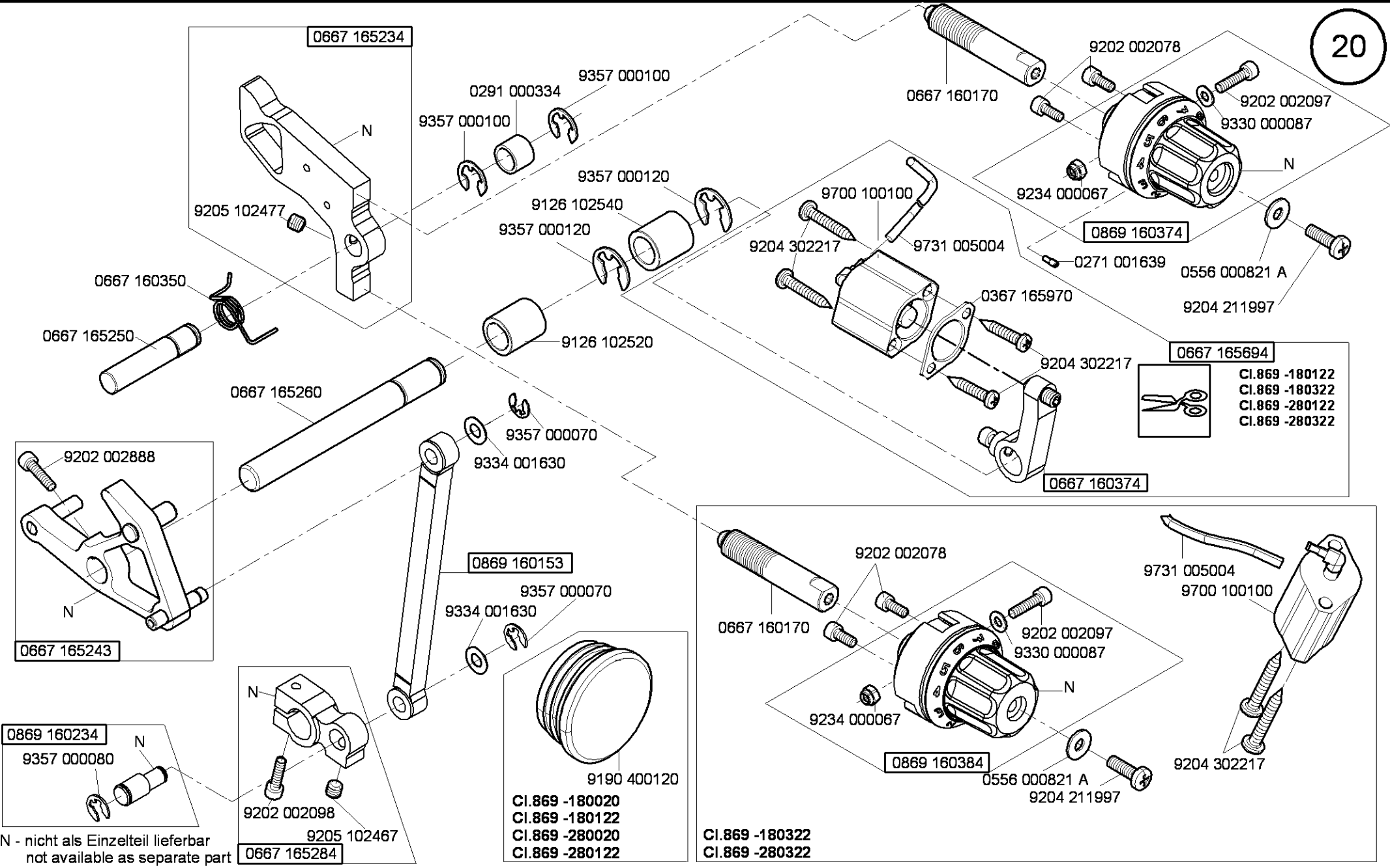

0667 165694

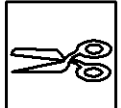

CI.869 -180122
 CI.869 -180322
 CI.869 -280122
 CI.869 -280322

N - nicht als Einzelteil lieferbar
 not available as separate part

9190 400120

CI.869 -180020
 CI.869 -180122
 CI.869 -280020
 CI.869 -280122

0869 160384

CI.869 -180322
 CI.869 -280322

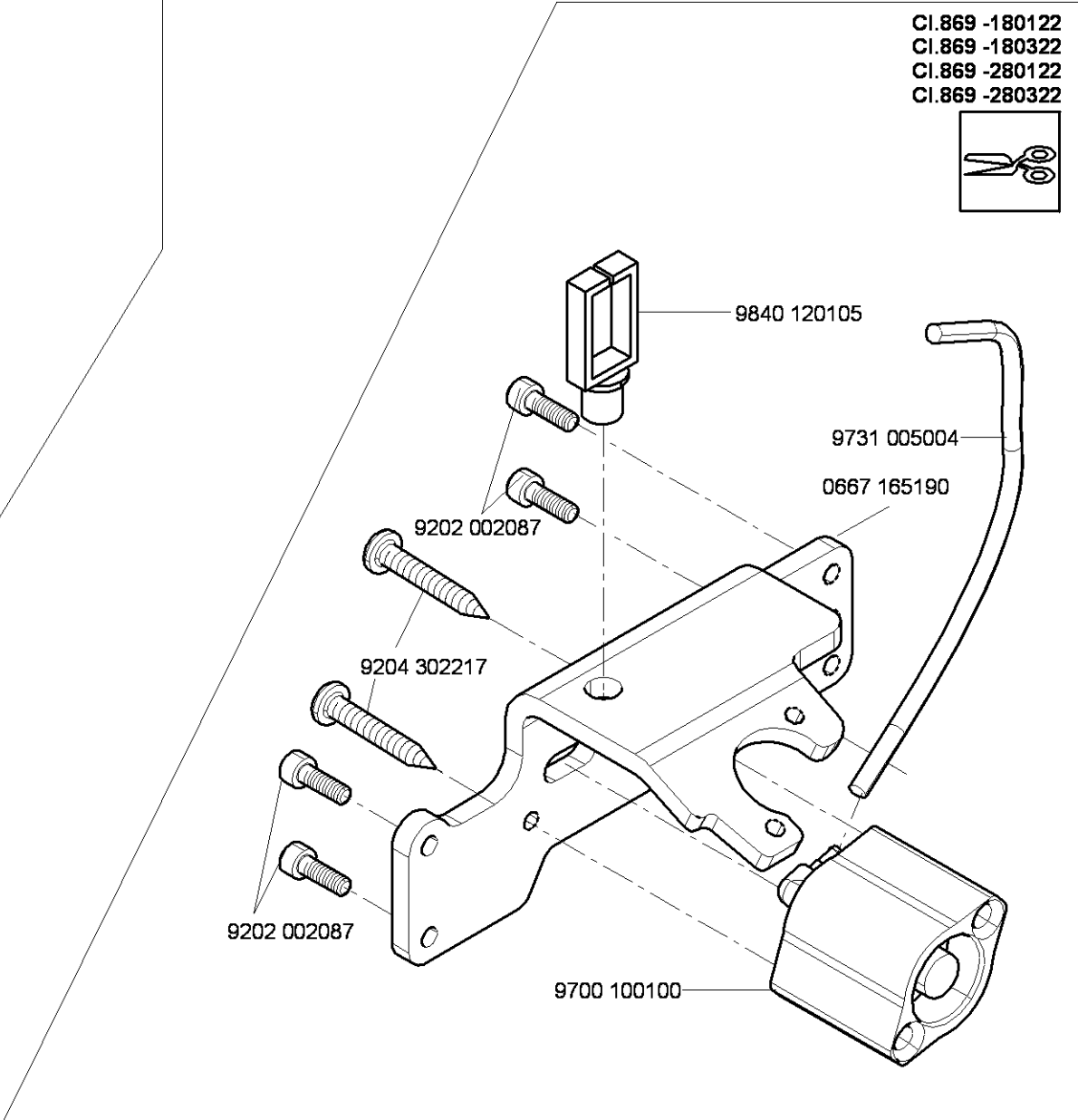
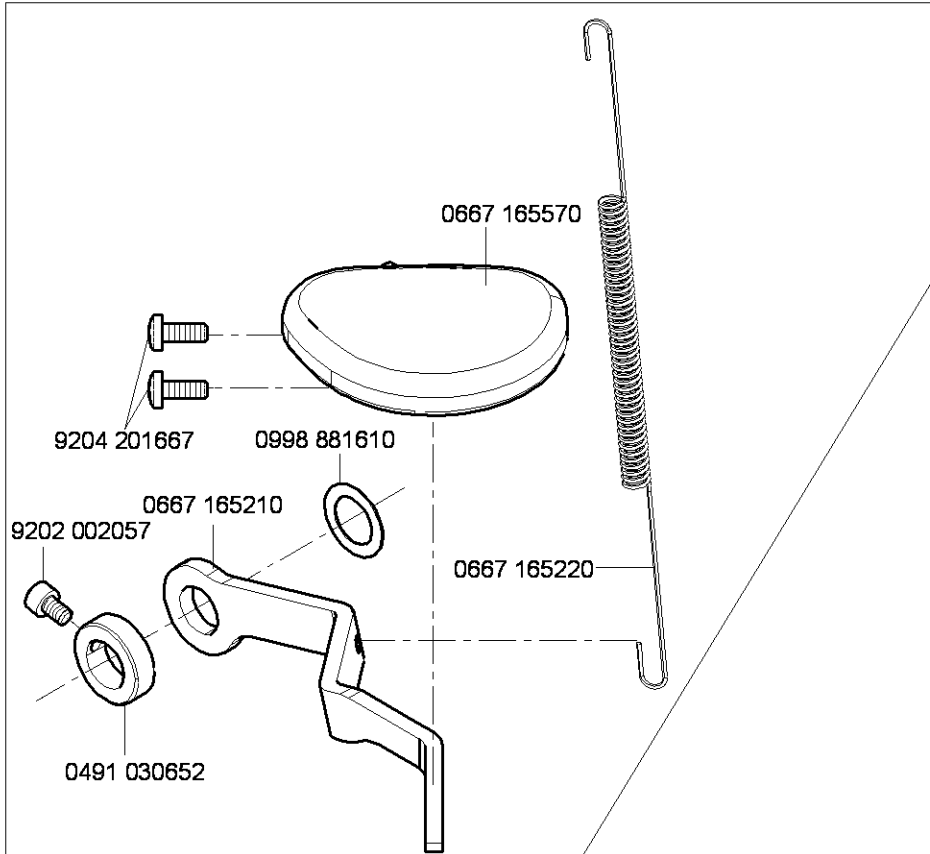

CI.869 -180122
CI.869 -180322
CI.869 -280122
CI.869 -280322

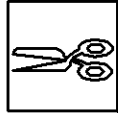

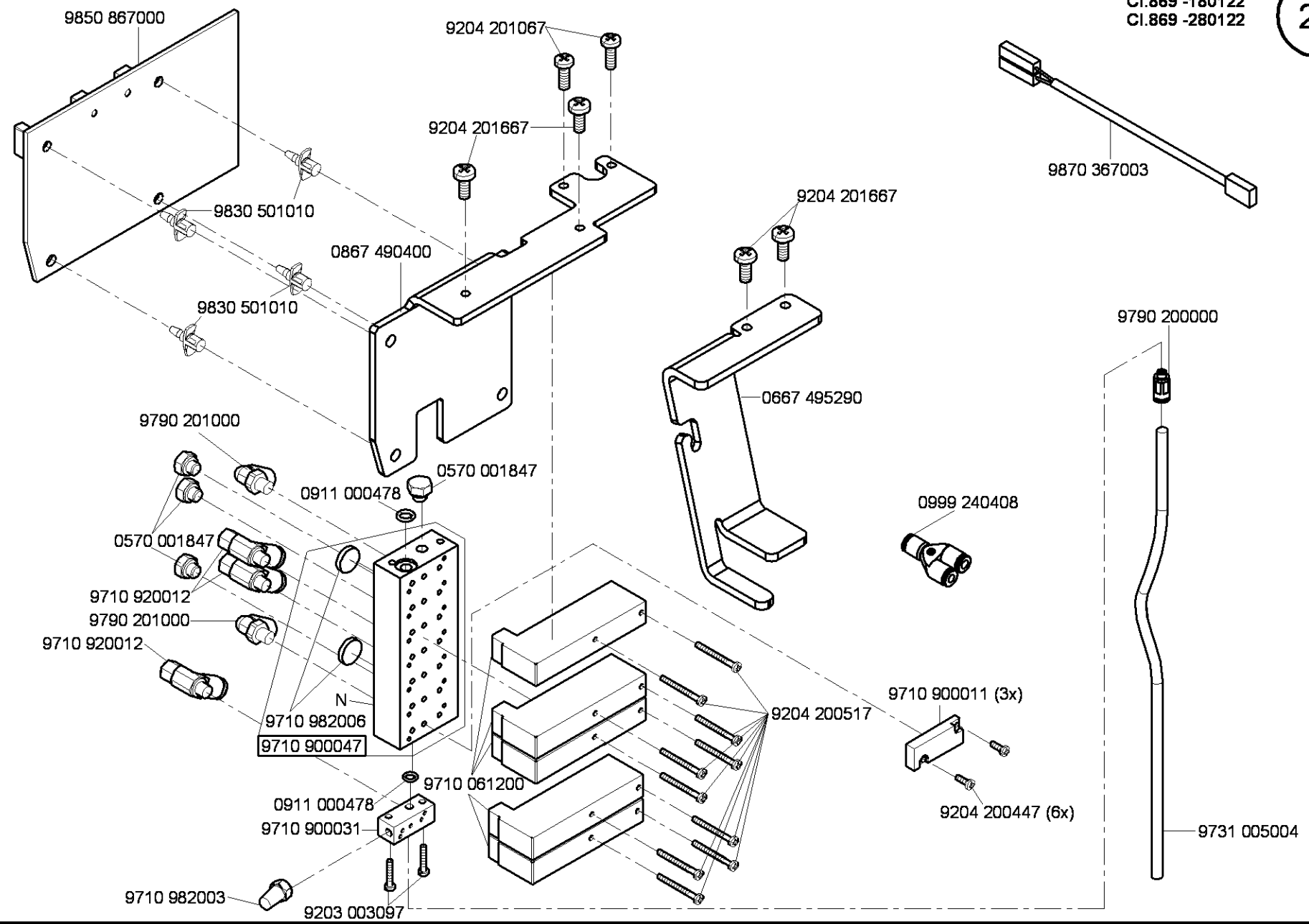

9880 867101

9199 000004

9850 867000

CI.869 -180322
CI.869 -280322

23

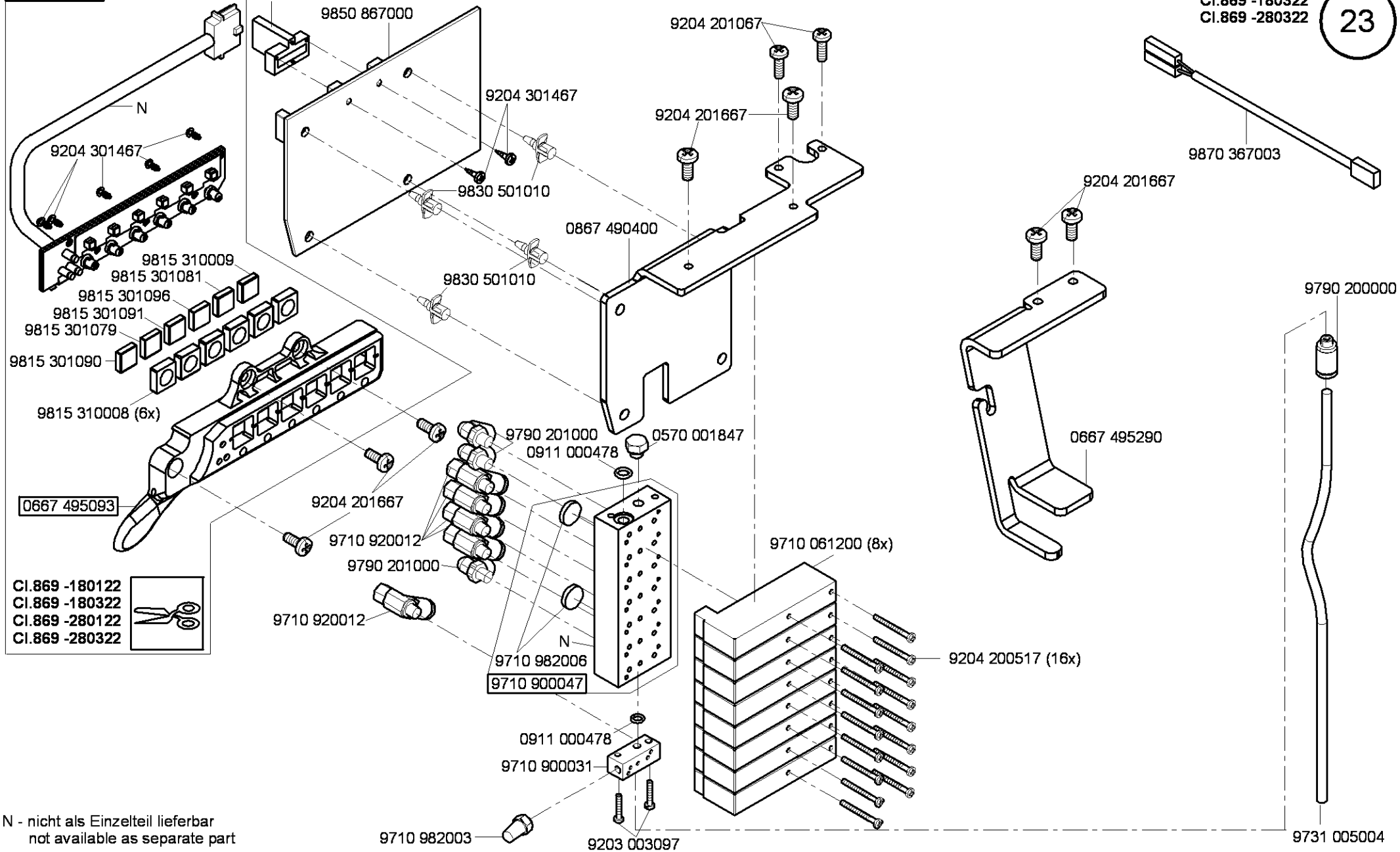

CI.869 -180122
 CI.869 -180322
 CI.869 -280122
 CI.869 -280322

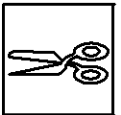

N - nicht als Einzelteil lieferbar
 not available as separate part

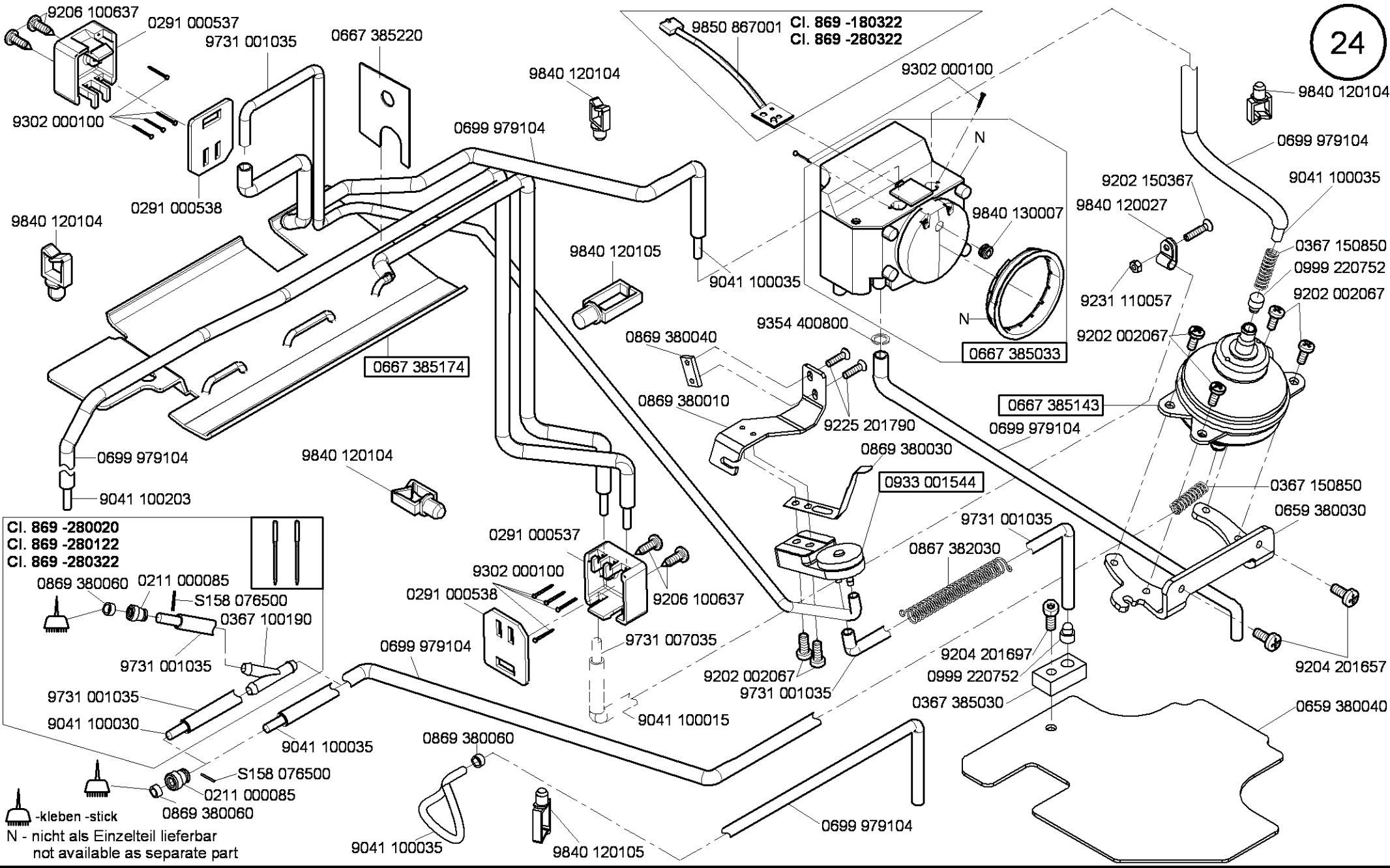

CI. 869 -280020
 CI. 869 -280122
 CI. 869 -280322

0869 380060 0211 000085
 S158 076500 0367 100190
 9731 001035
 9041 100030
 9041 100035
 9041 100035
 0869 380060
 S158 076500
 0211 000085
 0869 380060
 -kleben -stick
 N - nicht als Einzelteil lieferbar
 not available as separate part

9880 867102

CI.869 -180322
CI.869 -280322

0867 490024

- 9840 120003 (2x)
- 9840 123003 (2x)
- 9840 121001 (5x)
- 9840 120026 (2x)
- 9202 002077 (3x)
- 9207 170437 (2x)

CI.869 -180020
CI.869 -180122
CI.869 -280020
CI.869 -280122

0667 385180

0667 105120

9202 002077

0667 105144

9204 212057

9204 211997

0699 989250

9204 212057

0667 105060

9204 212057

9204 201647

0367 495010

9204 201647

0367 495010

9204 201647

0367 495010

0291 000347

0291 000347

9202 003738

0667 110340

9190 100108

9225 201770

0667 115280

0219 000321

N

CI.869 -180122
CI.869 -180322
CI.869 -280122
CI.869 -280322

0219 000321

N - nicht als Einzelteil lieferbar
not available as separate part

CI.869 -180020
CI.869 -180122
CI.869 -280020
CI.869 -280122

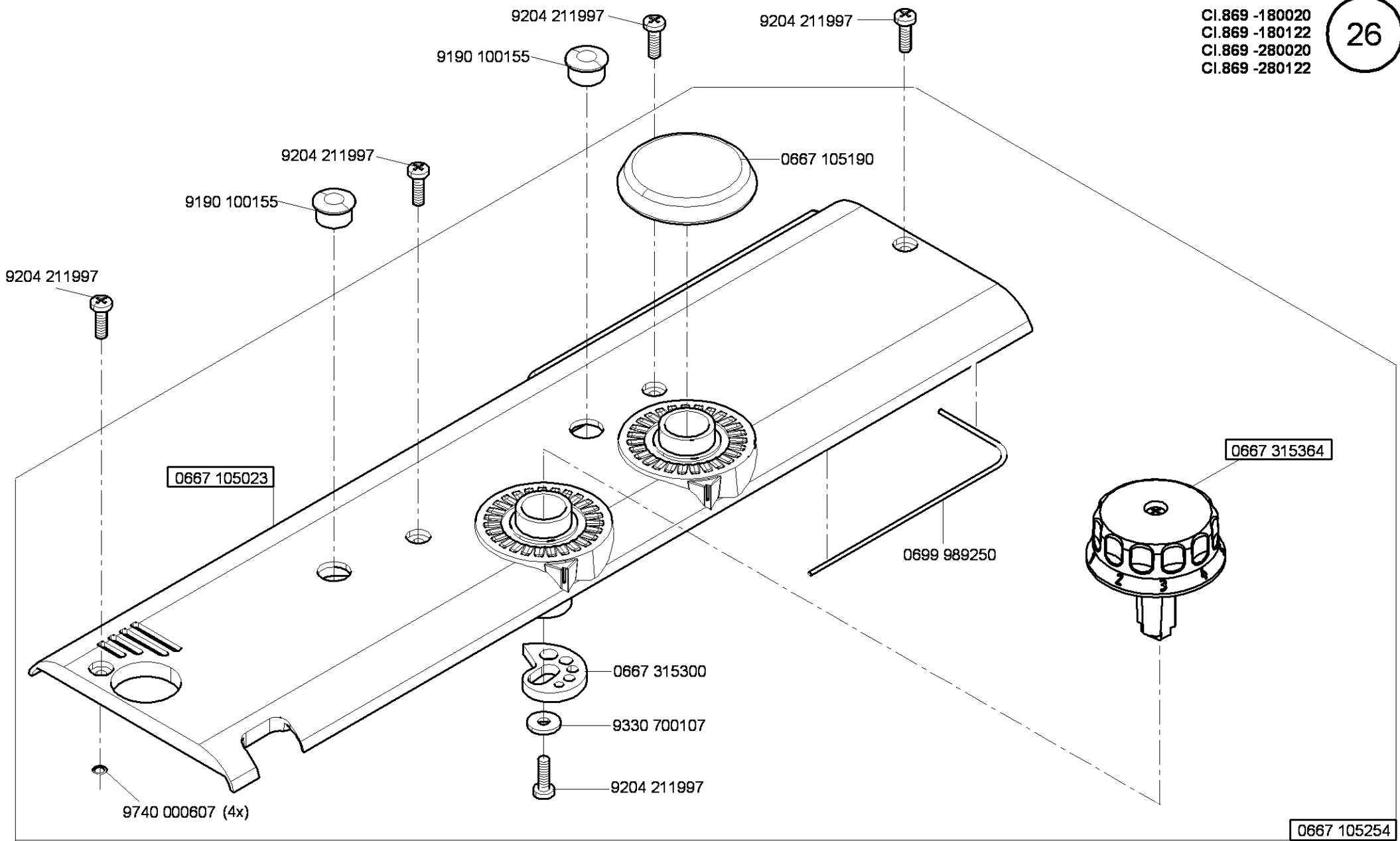

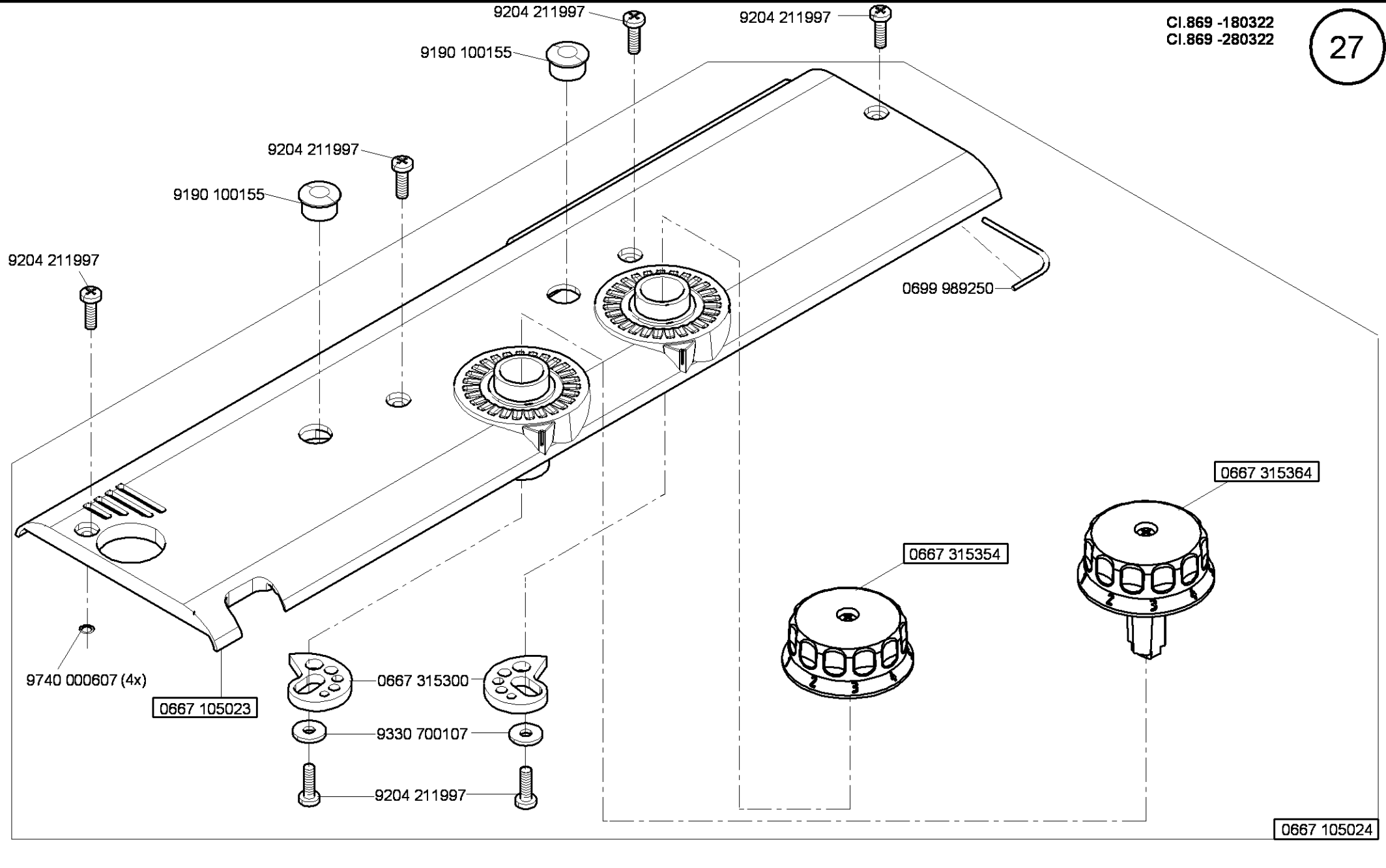

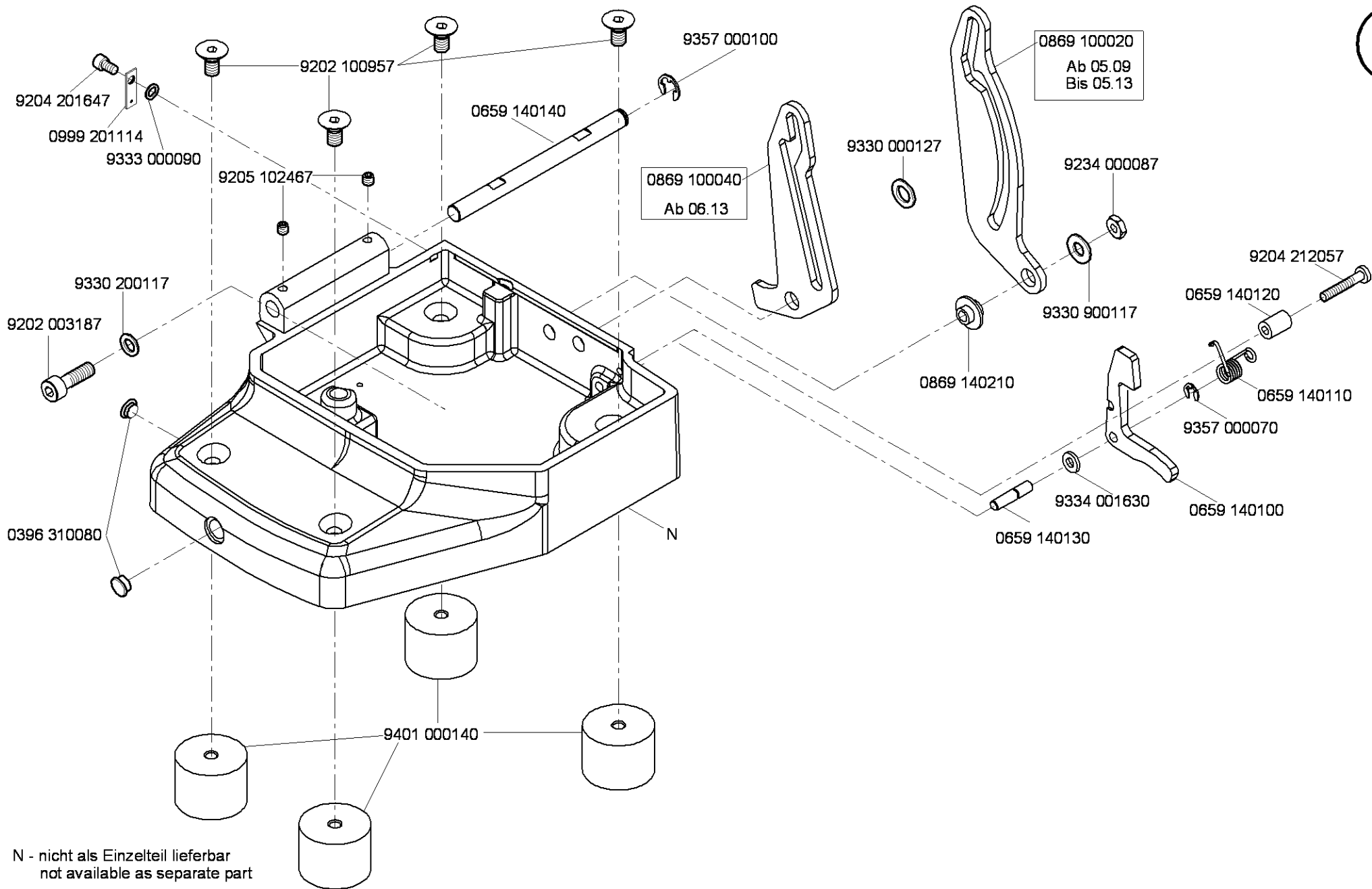

N - nicht als Einzelteil lieferbar
not available as separate part

CI.869 -180020
CI.869 -180122
CI.869 -180322

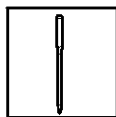

29

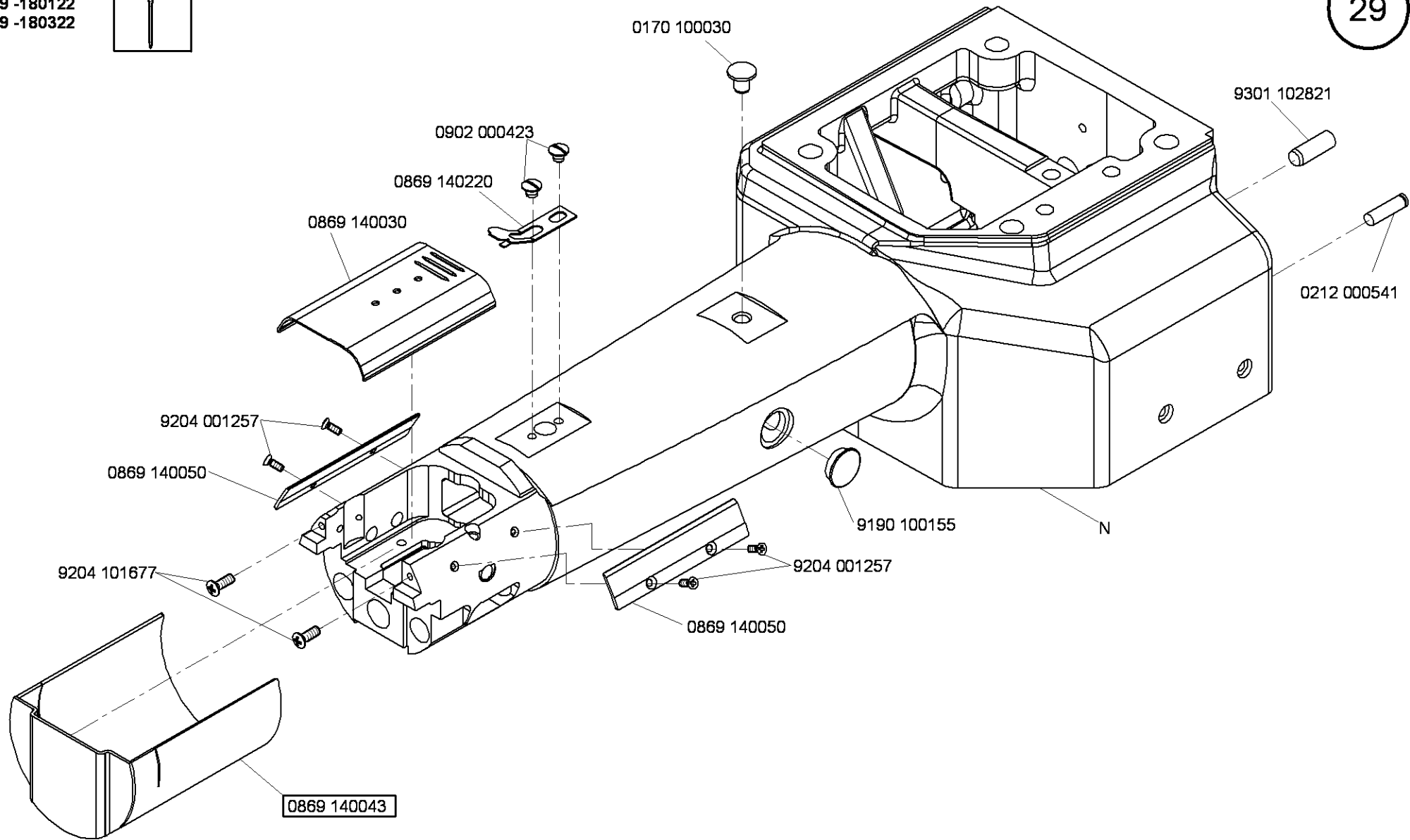

CI.869 -280020
CI.869 -280122
CI.869 -280322



30

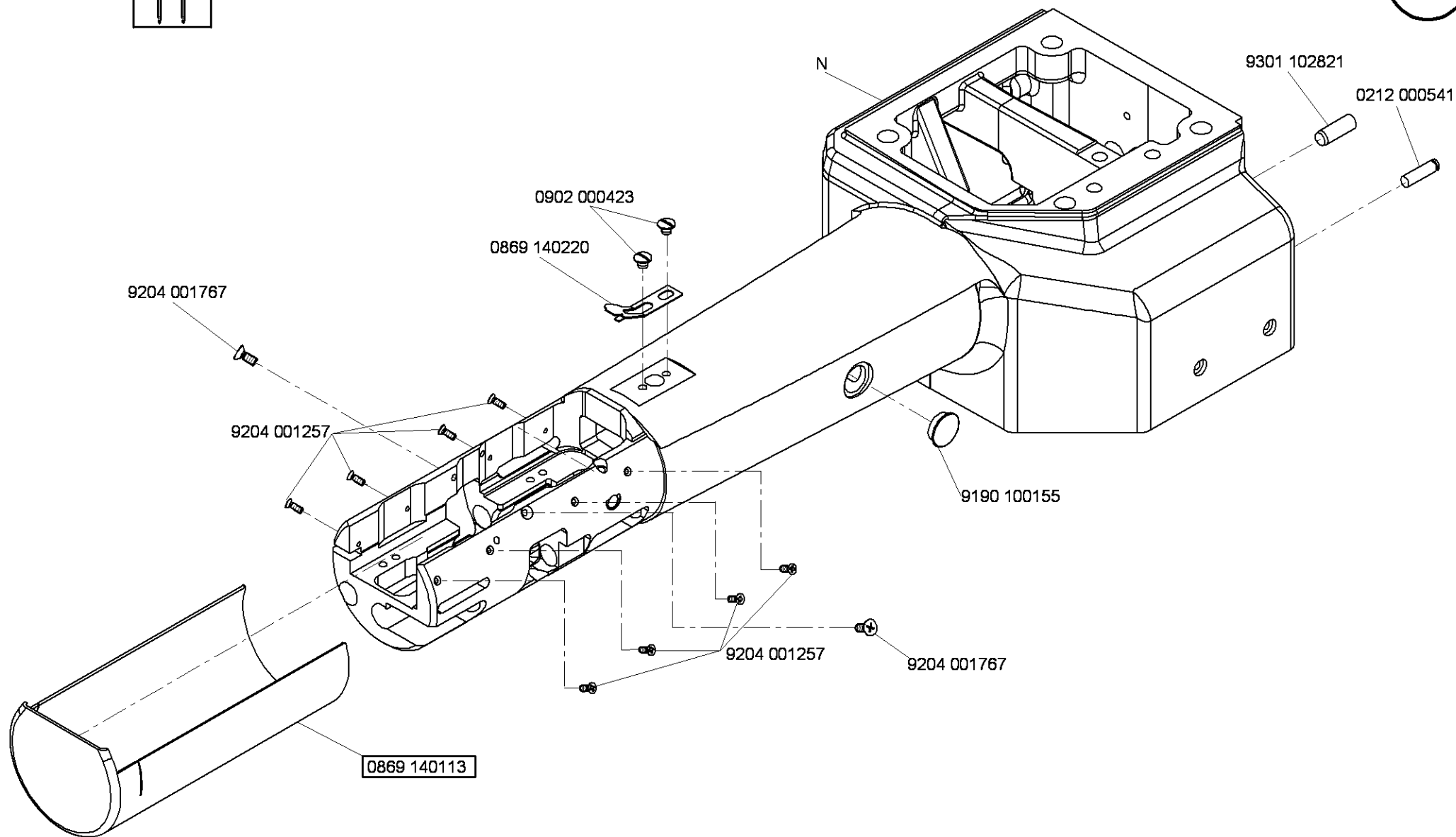

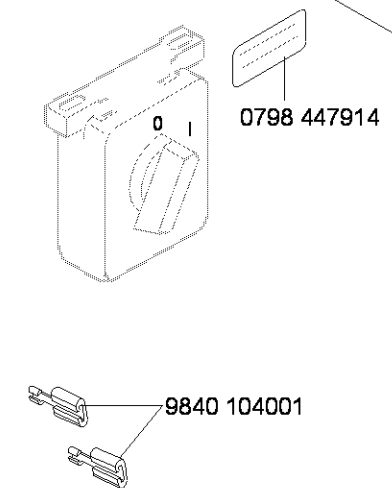
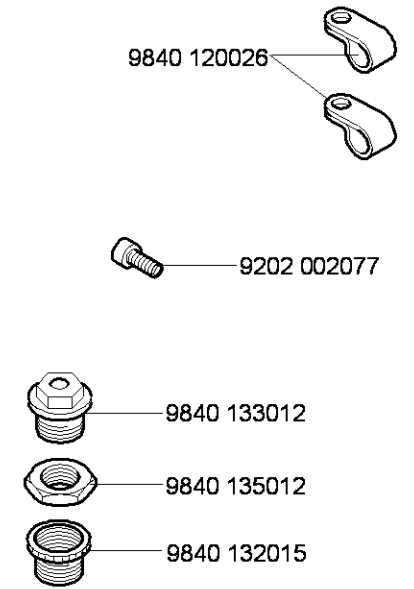
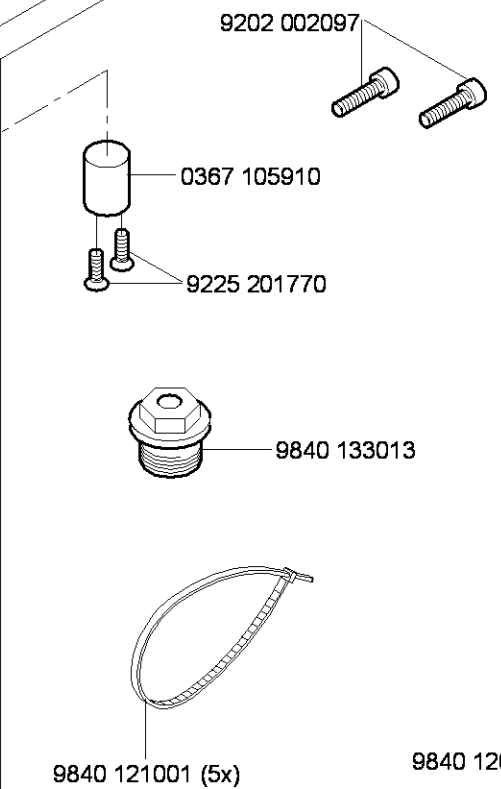
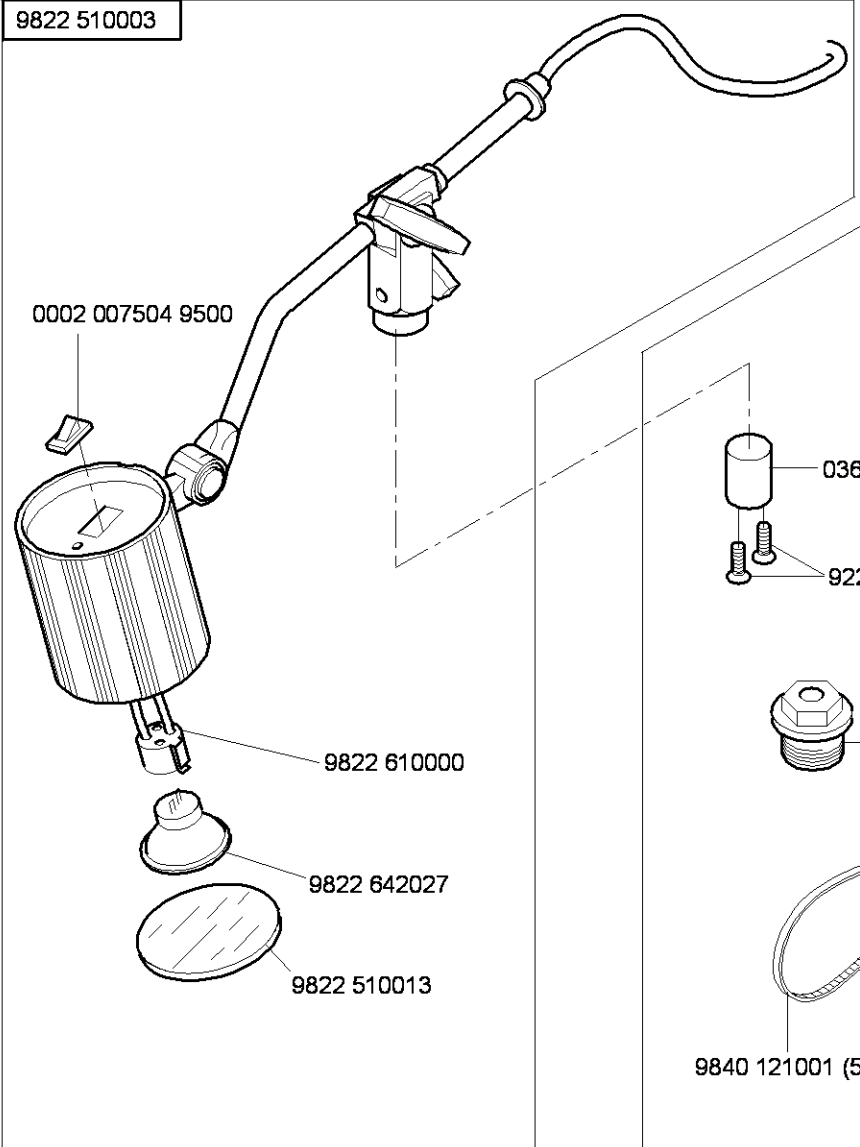

9880 867100

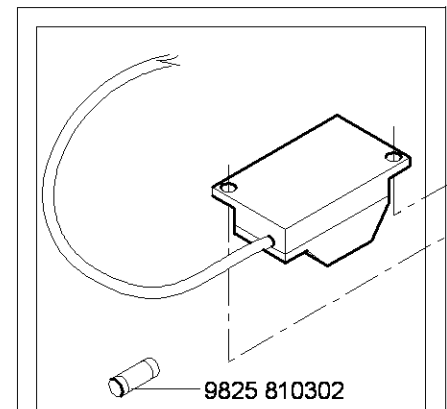
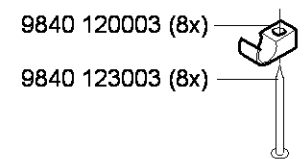

0798 500088

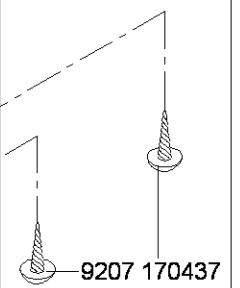

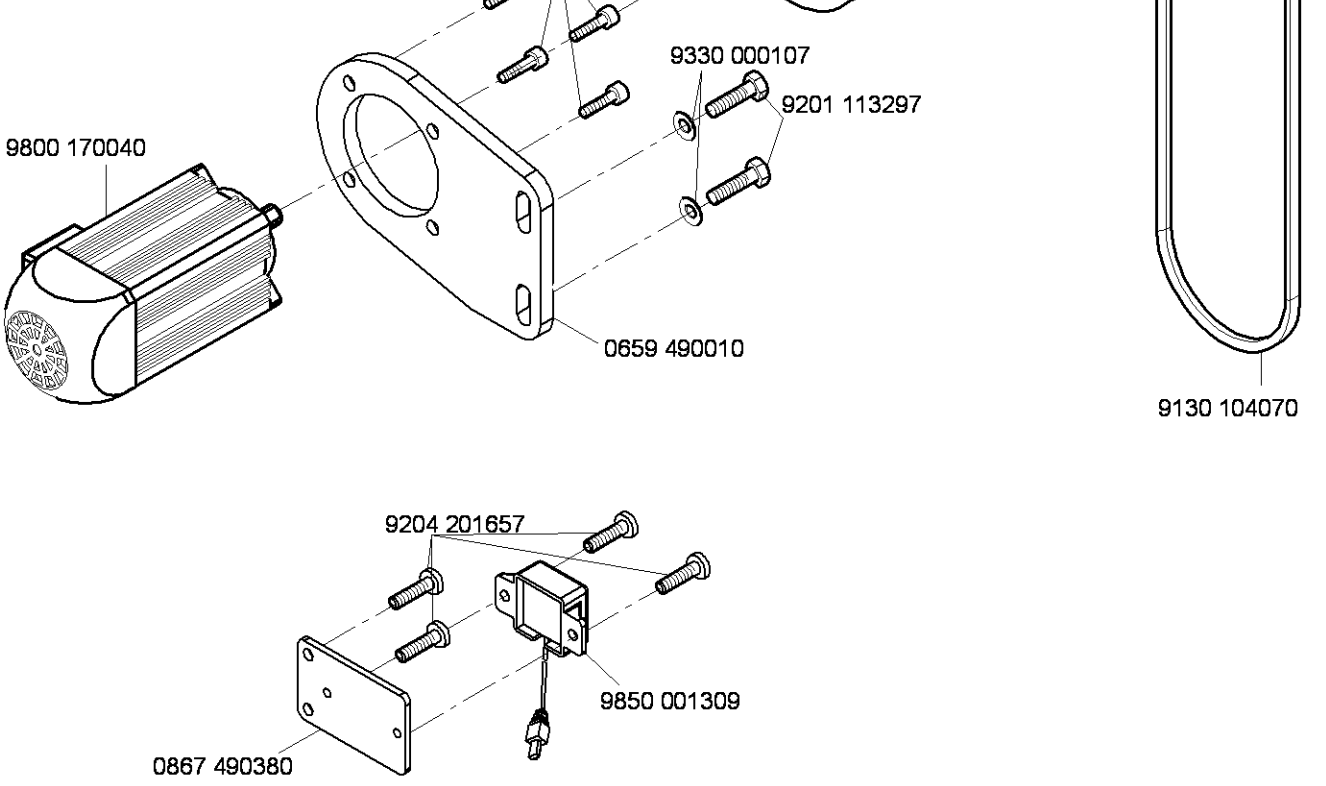
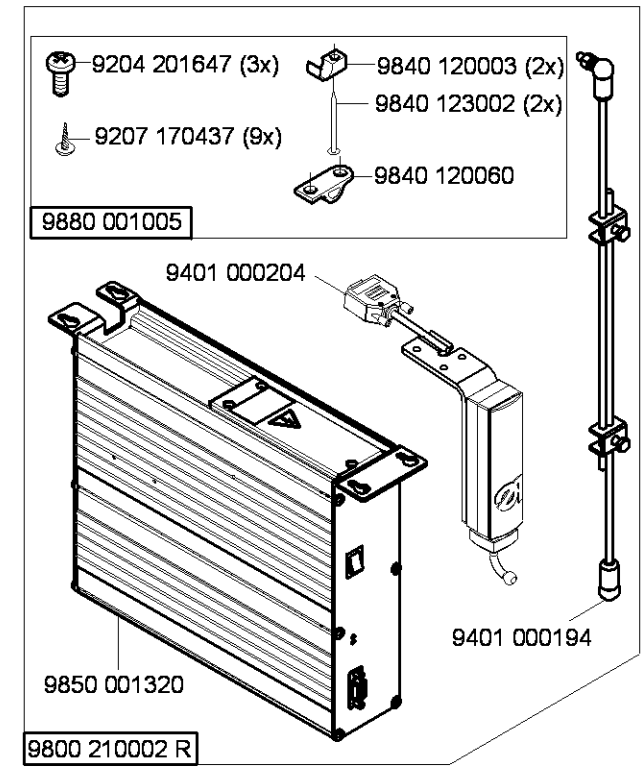
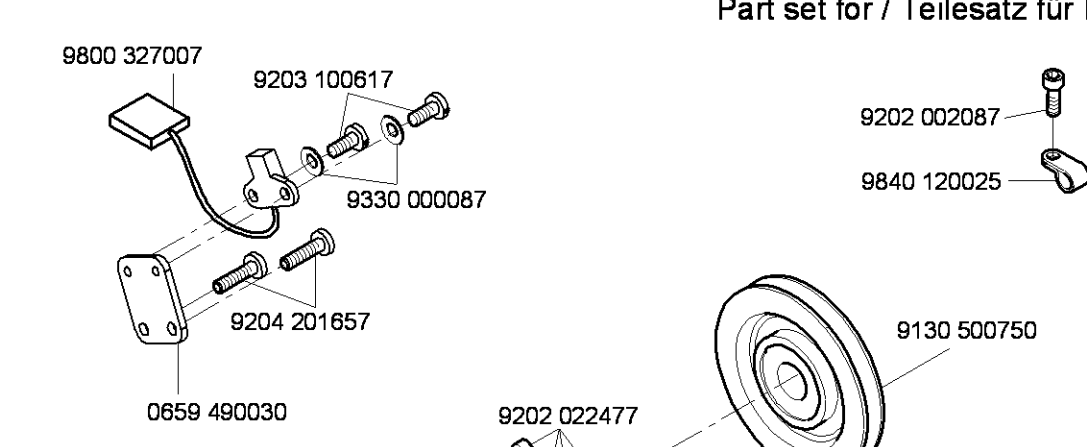
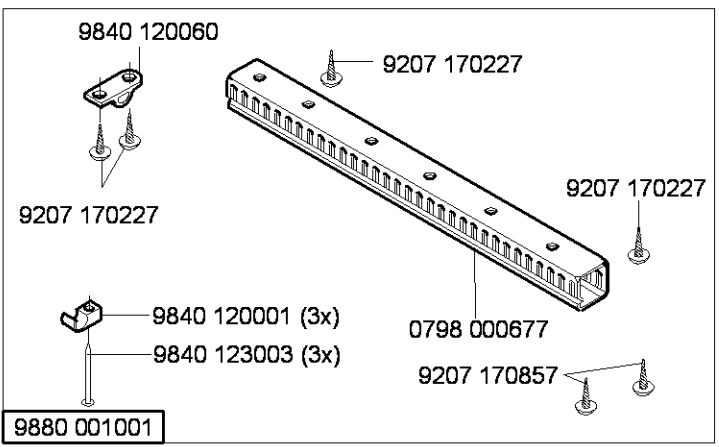

N - nicht als Einzelteil lieferbar
not available as separate part

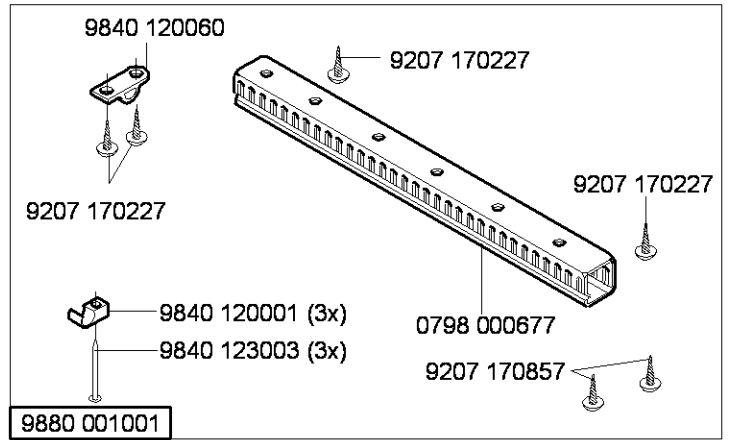
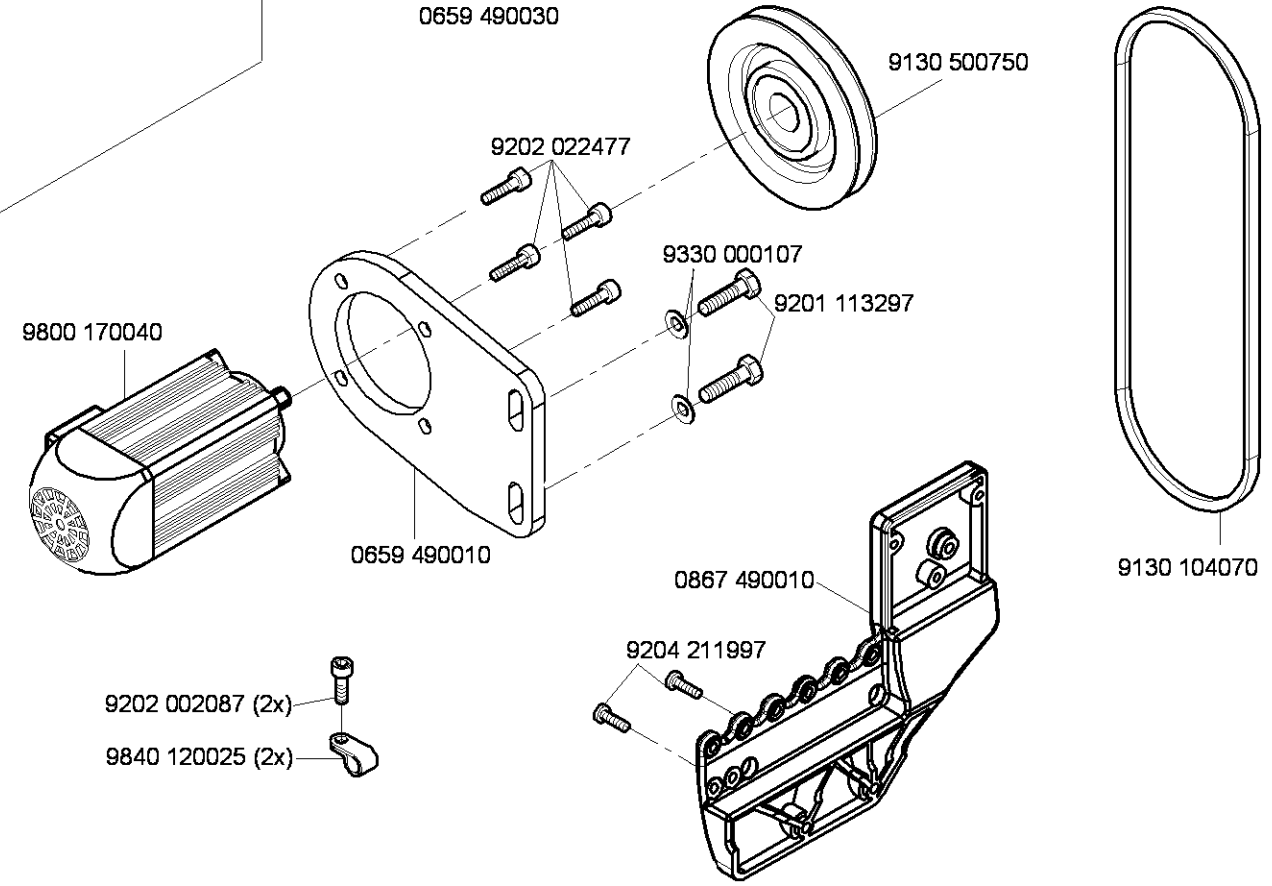
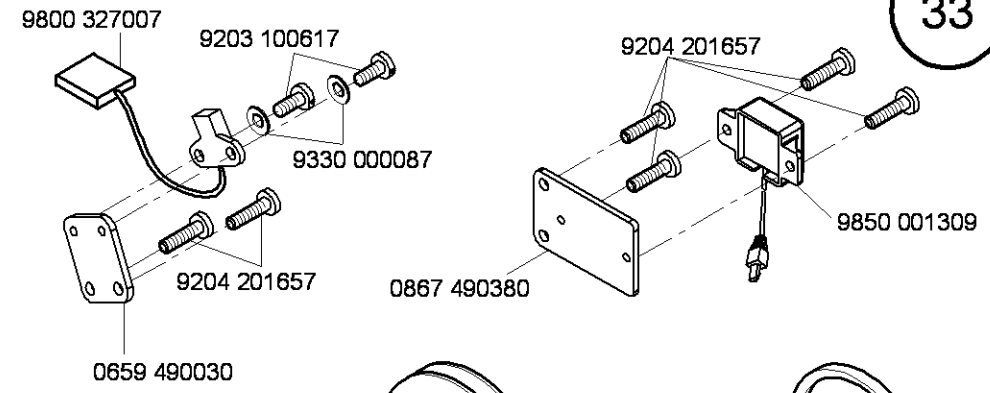
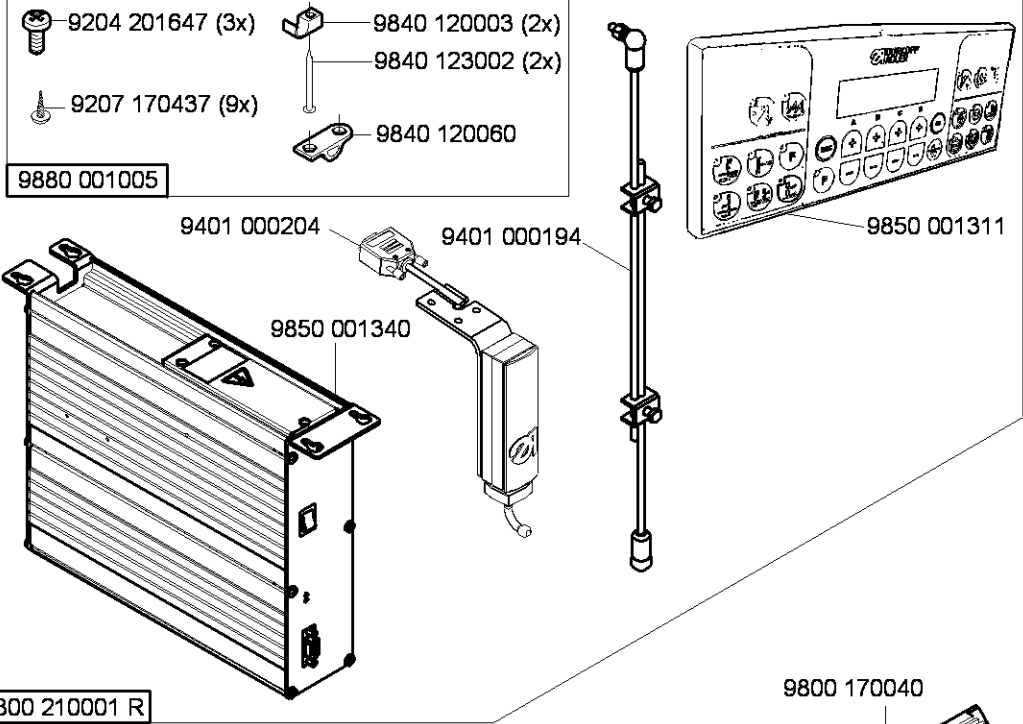

N - nicht als Einzelteil lieferbar
not available as separate part

Part set for/Teilesatz für EFKA DC1550/DA321G

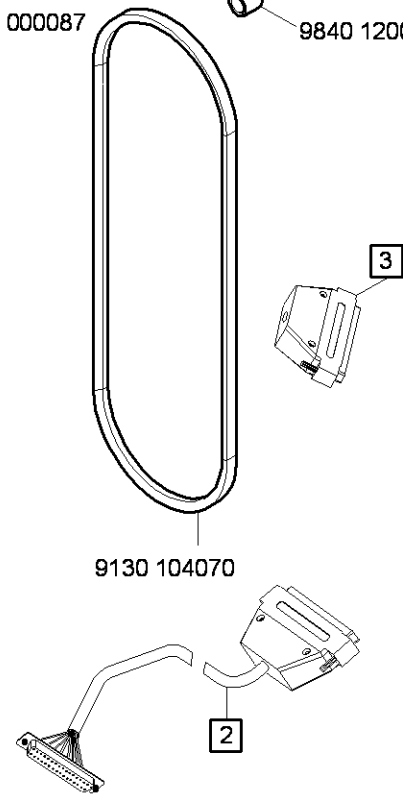
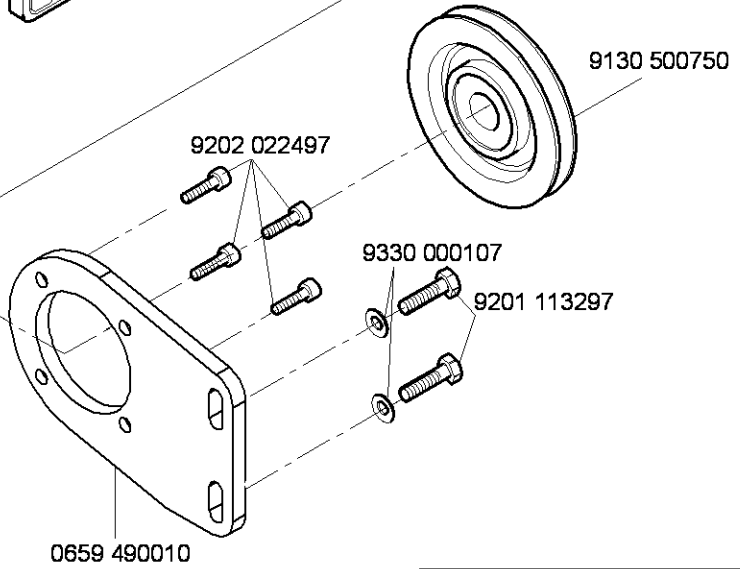
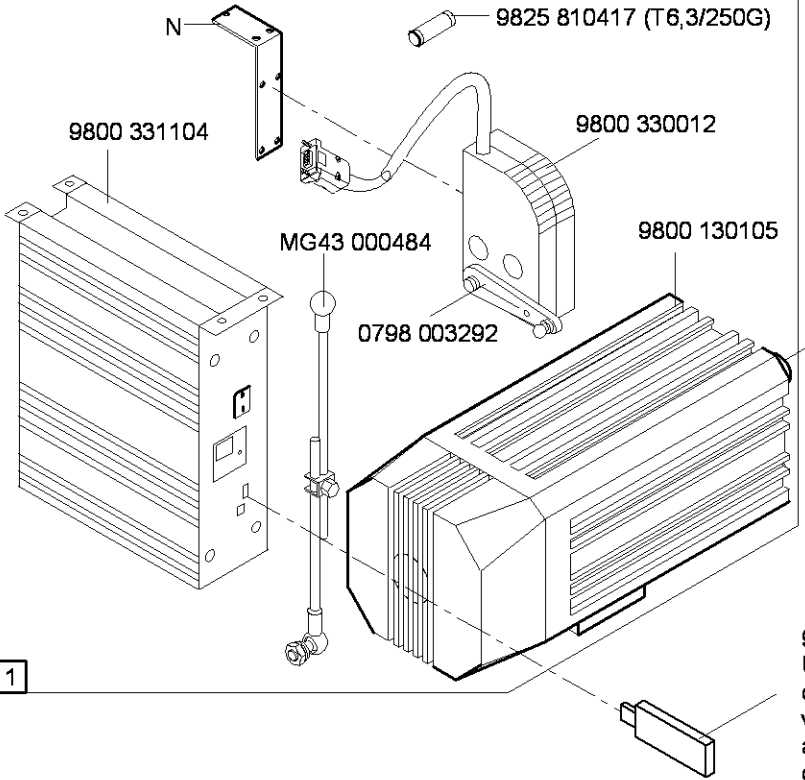
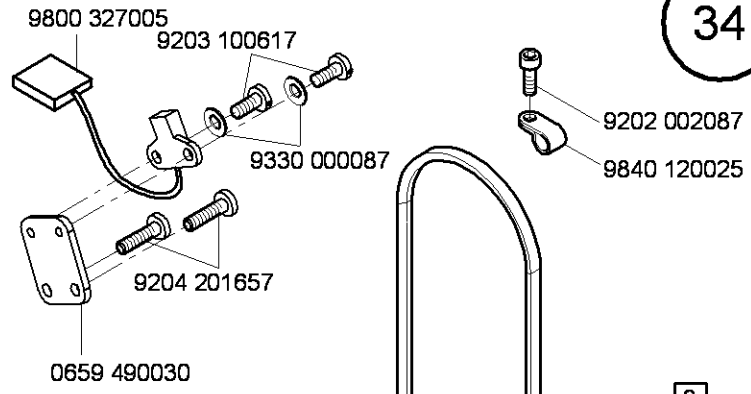
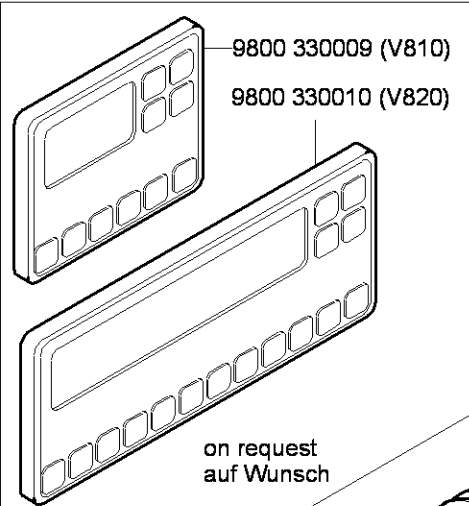
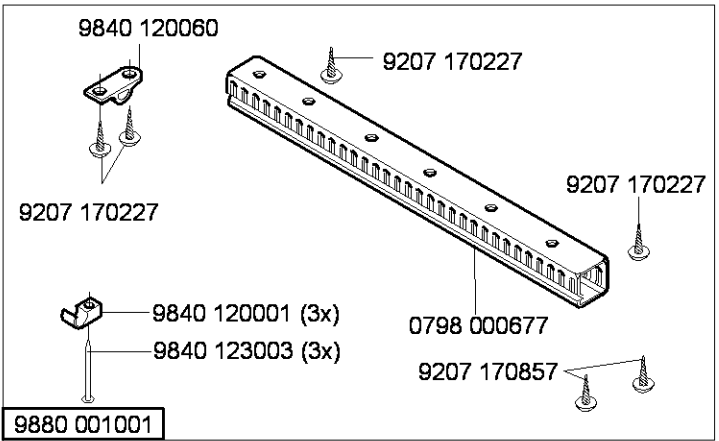

9805 791113
USB MEMORY STICK
on request
without program
auf Wunsch
ohne programm

Teilesatz/Set	1	2	3
9880 669002	9800 130104 R	9870 867000	-
9880 669003	9800 130104 R	-	9870 767019
9880 669004	-	9870 867000	-
9880 669005	-	-	9870 767019

N - nicht als Einzelteil lieferbar
not available as separate part

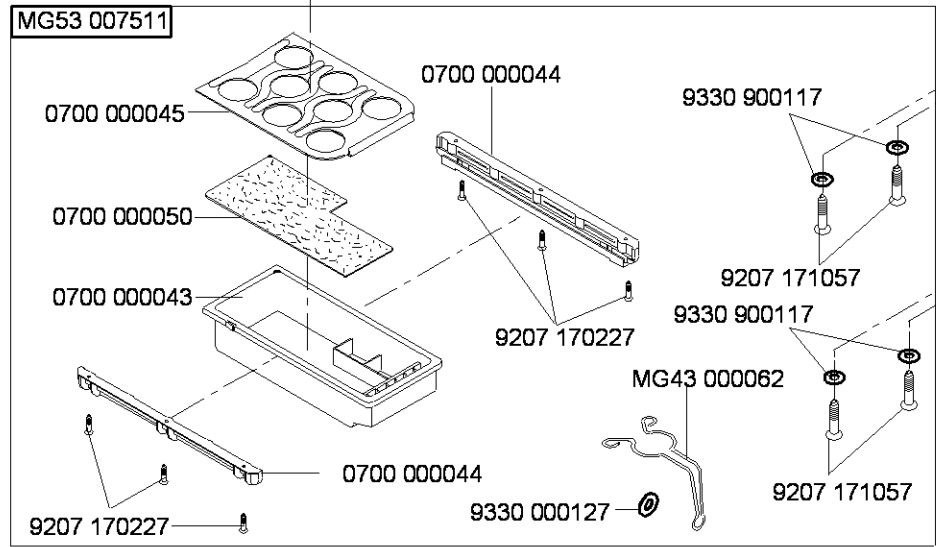
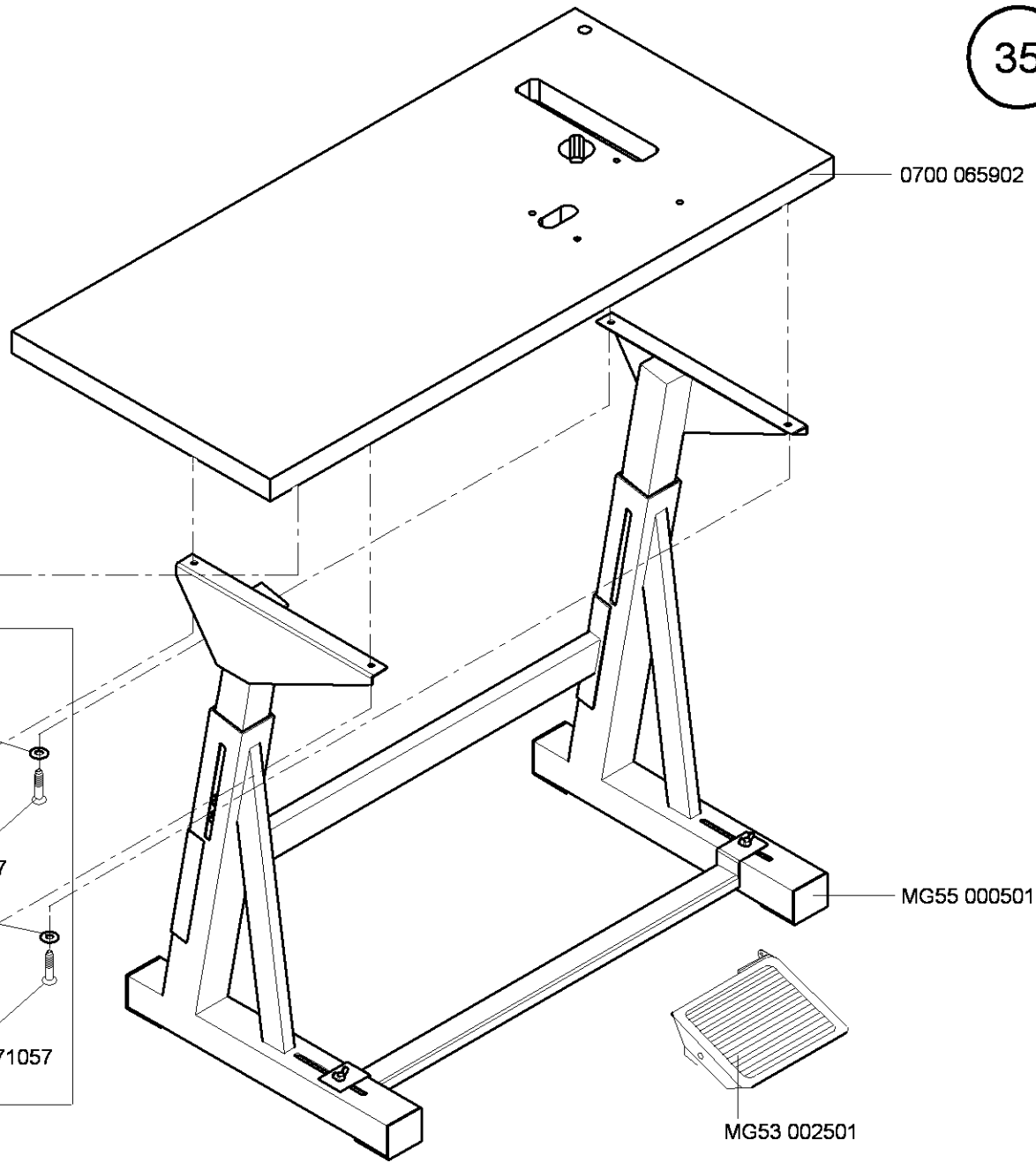

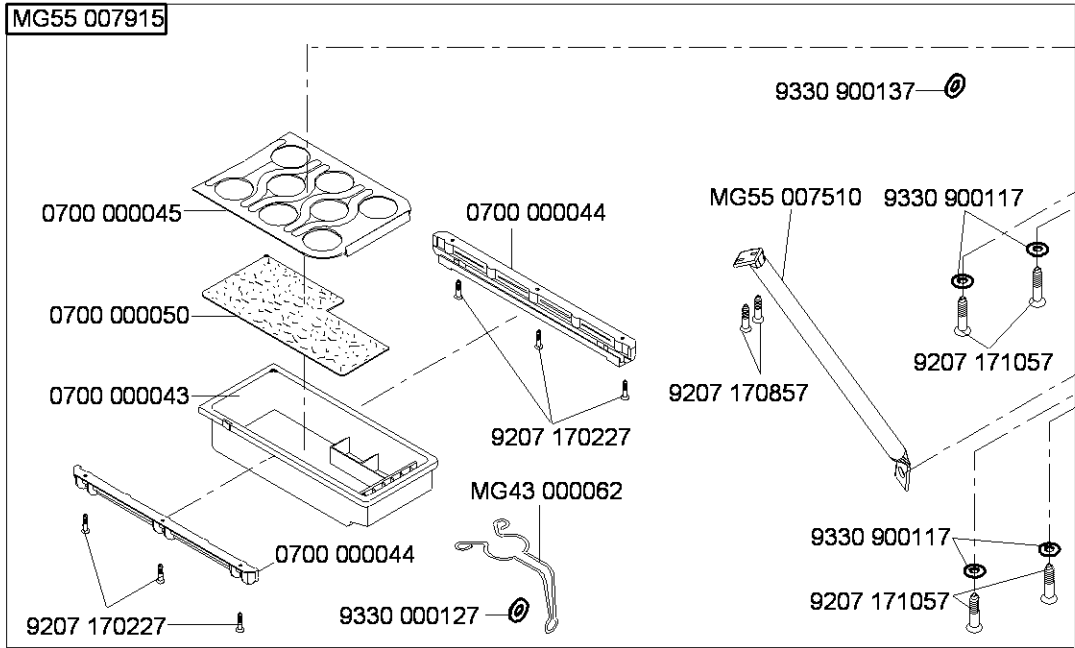
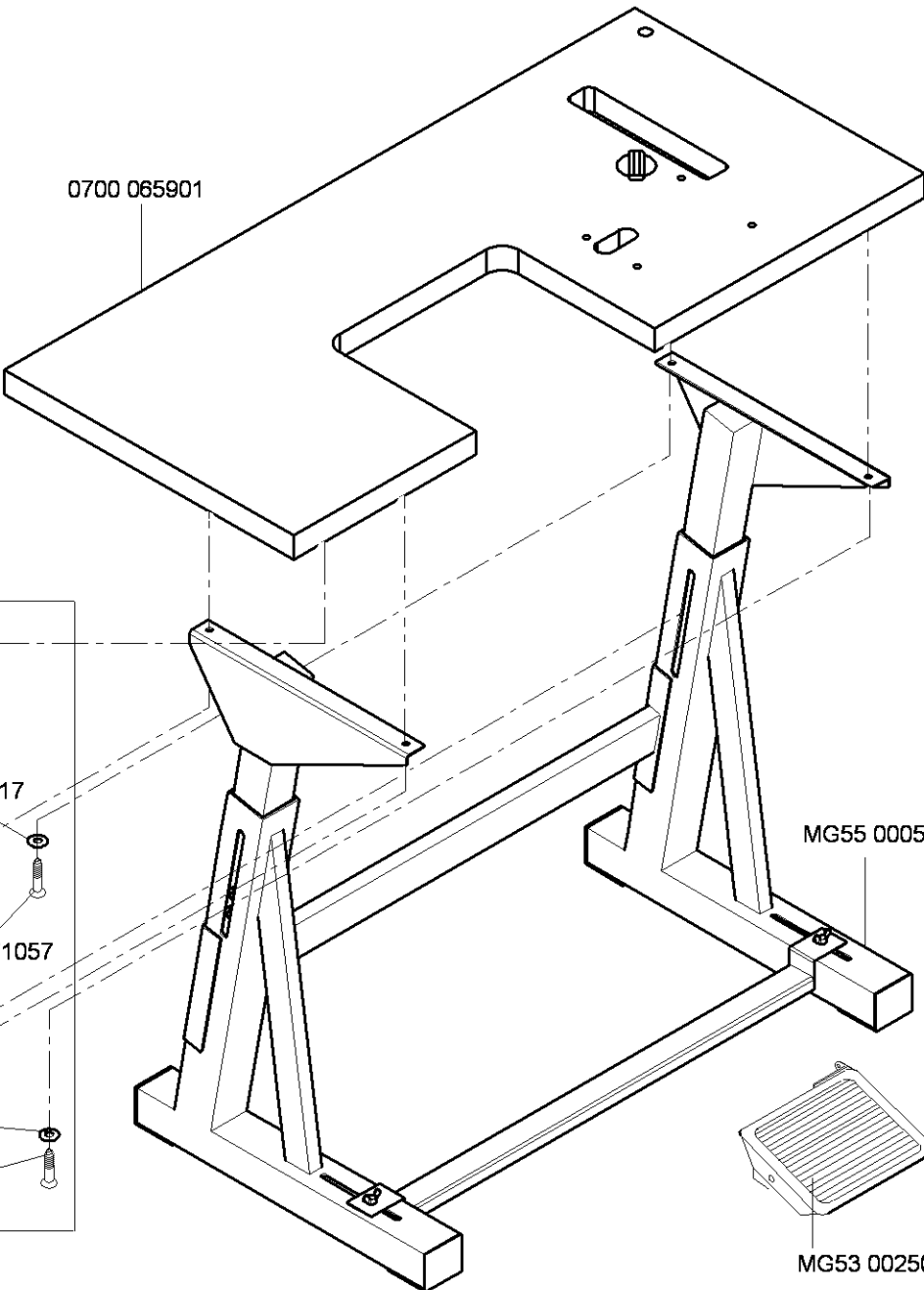

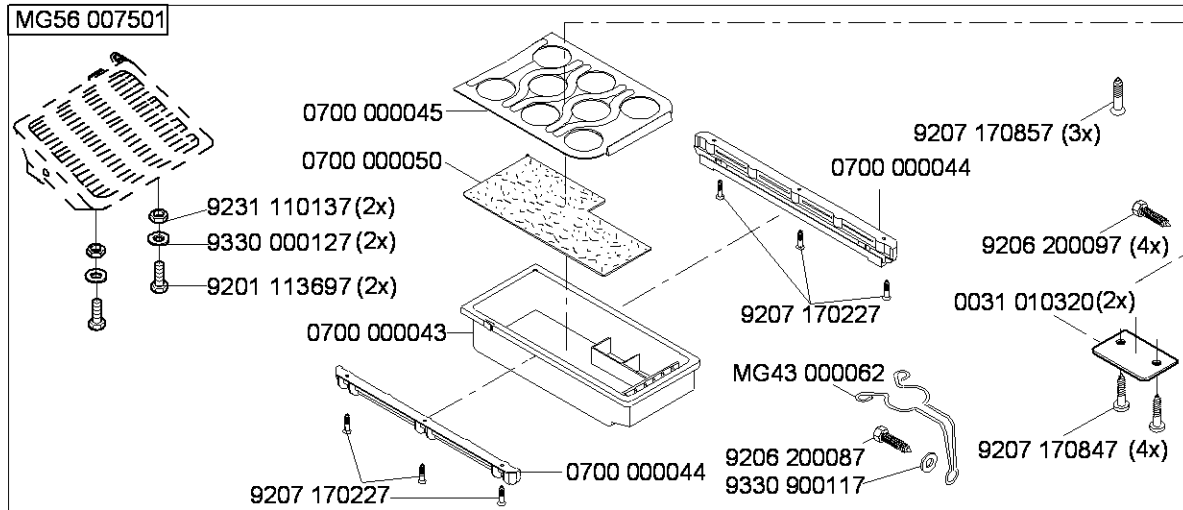
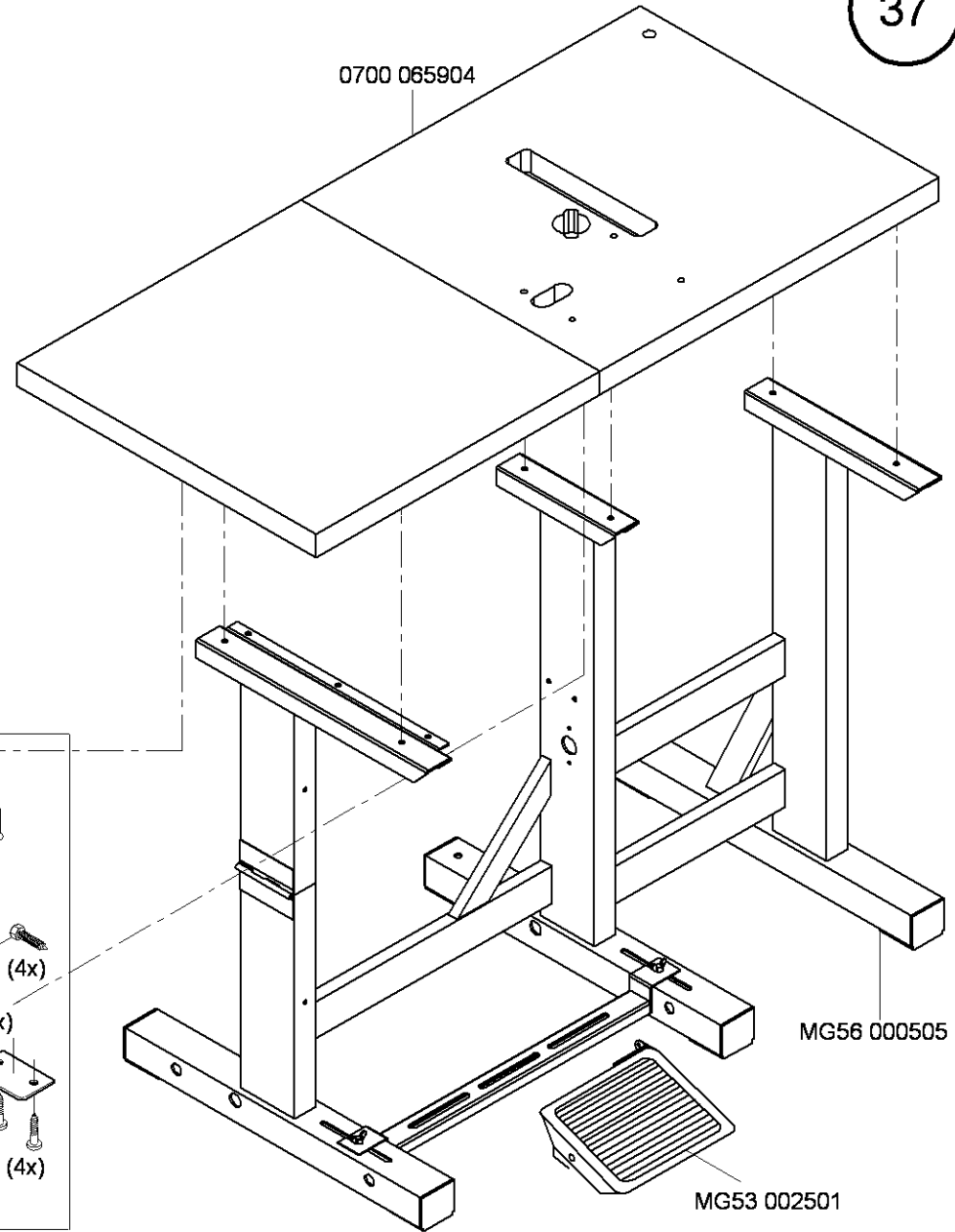
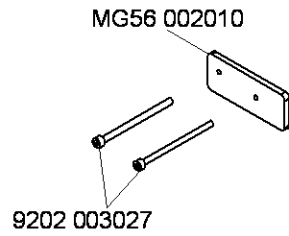
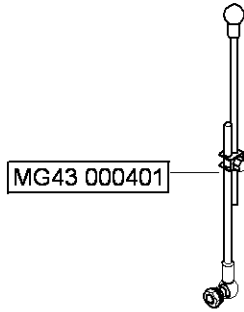
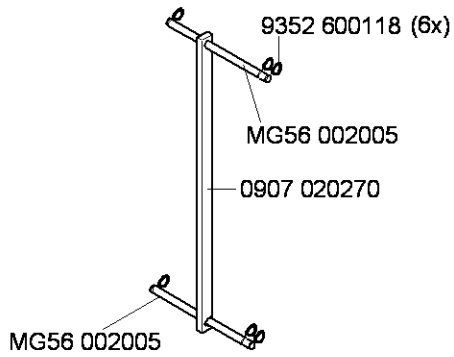

auf Wunsch
on request

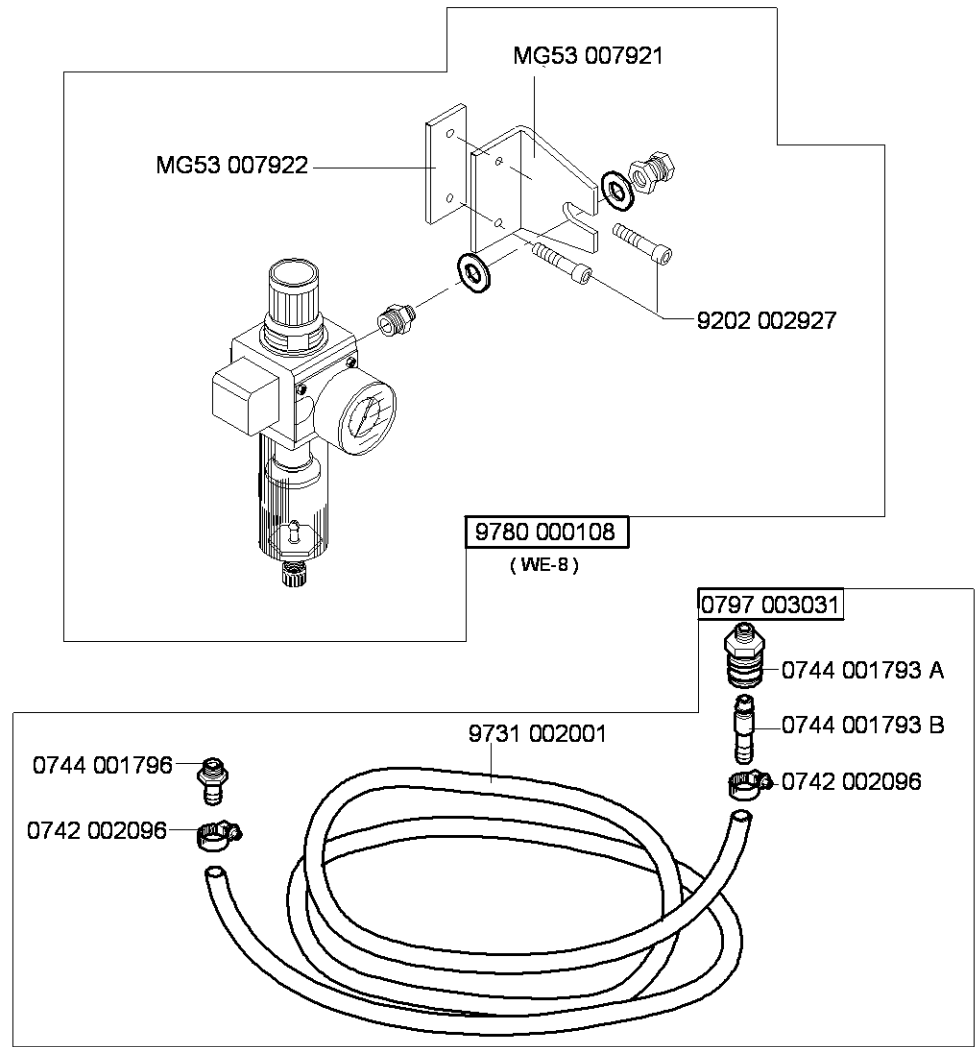

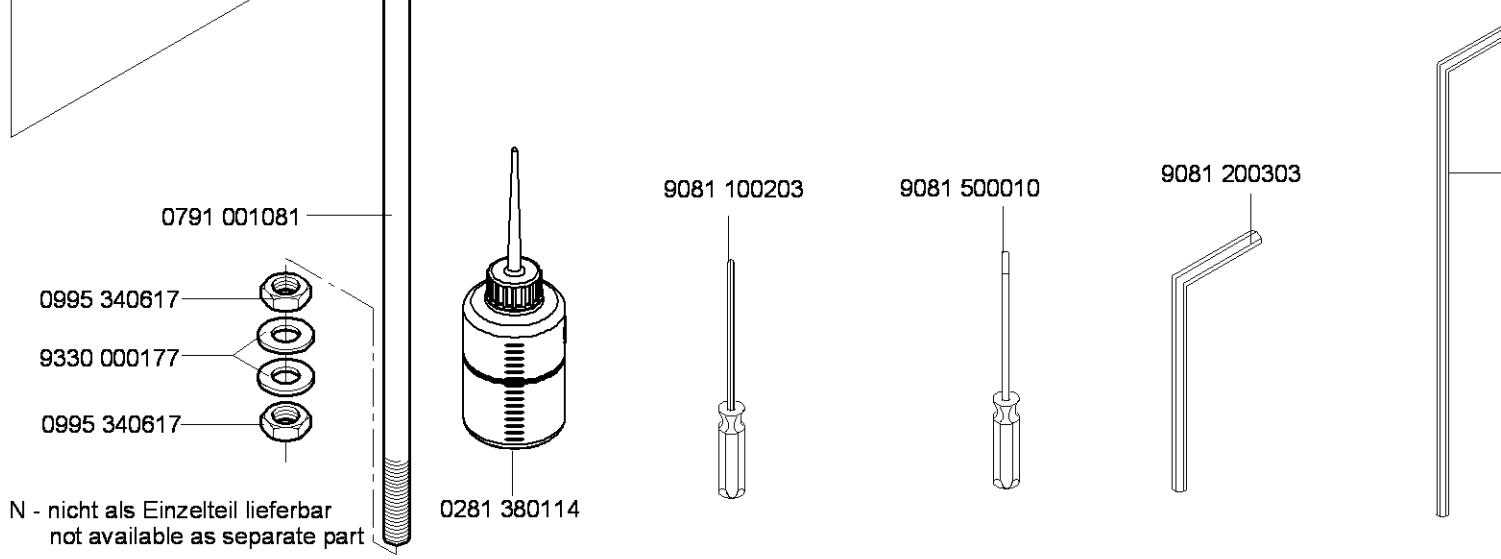
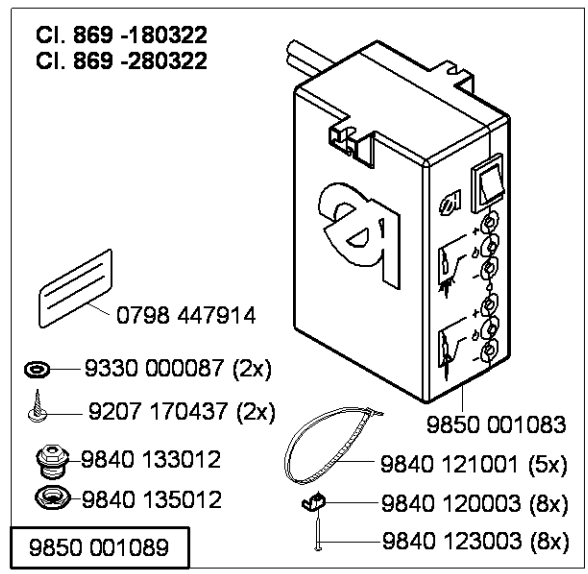
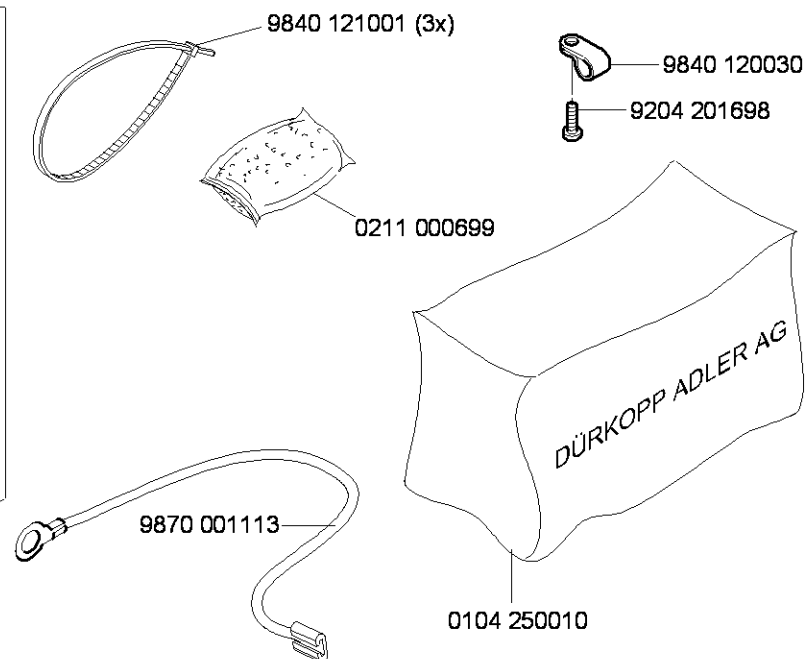
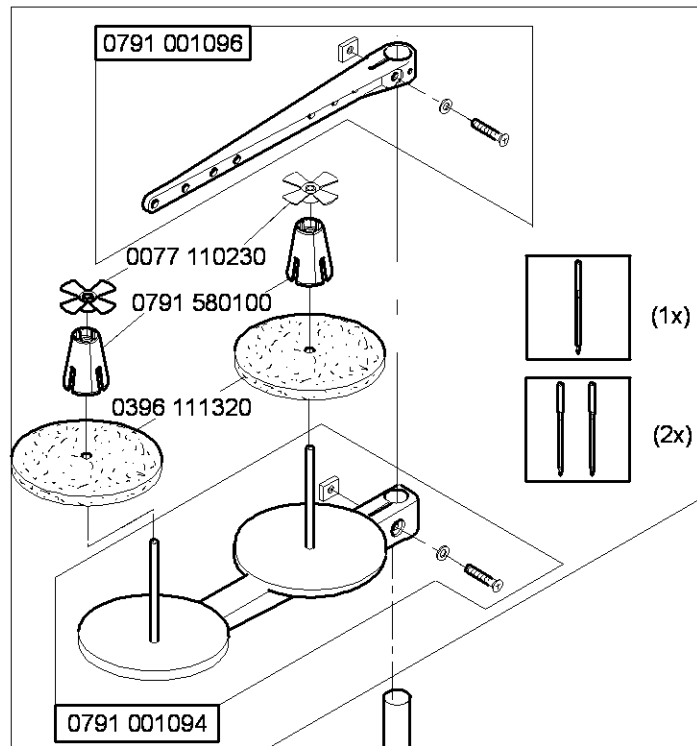

N - nicht als Einzelteil lieferbar
not available as separate part

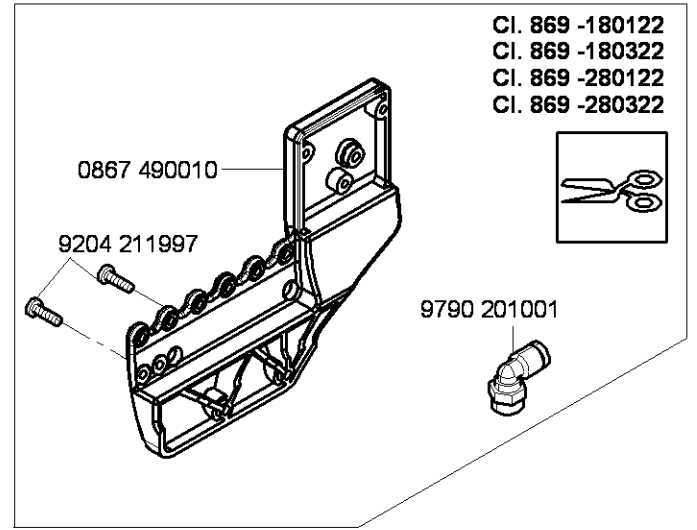
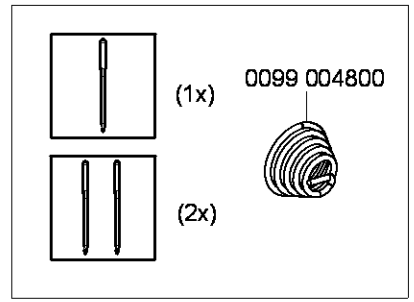

CI. 869 -180122
CI. 869 -180322
CI. 869 -280122
CI. 869 -280322

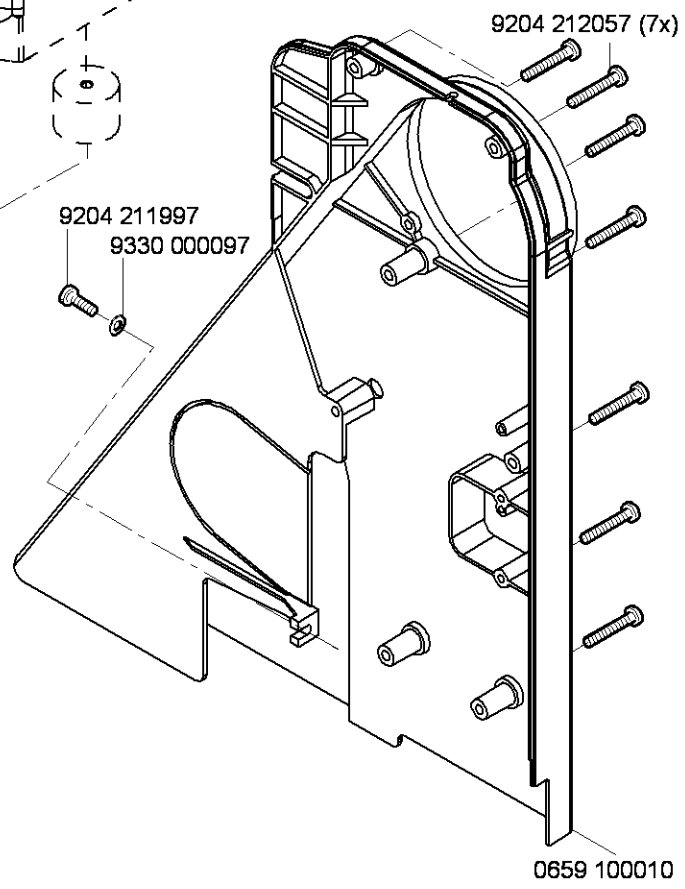
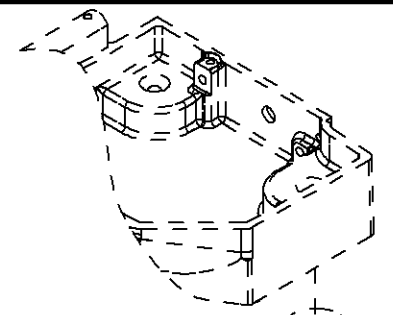
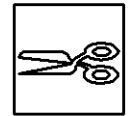

CI. 869 -180020
CI. 869 -280020

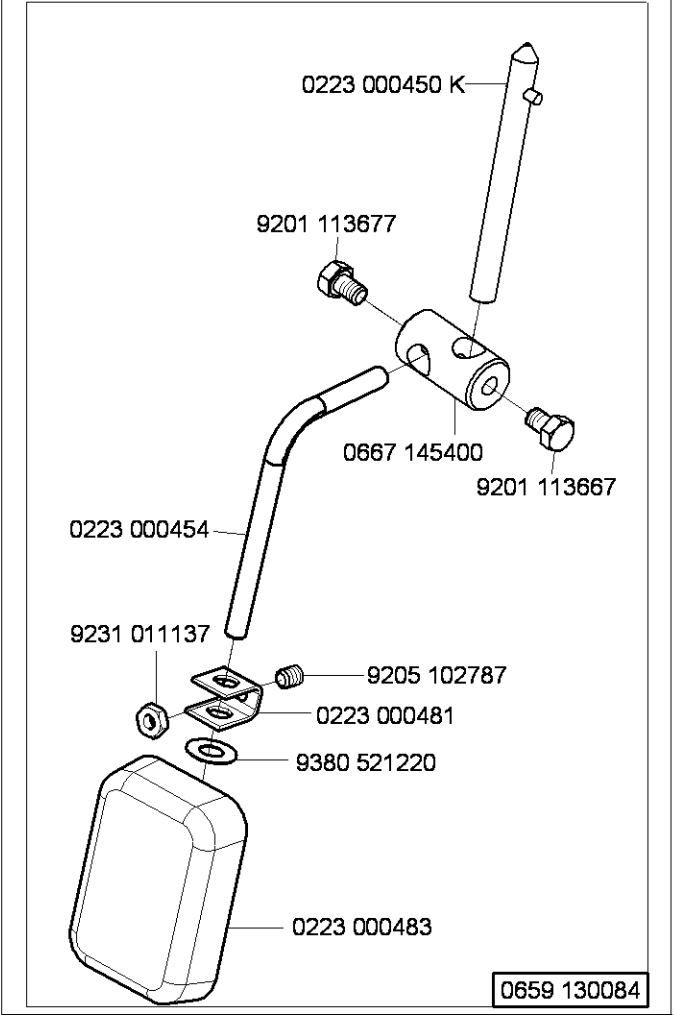
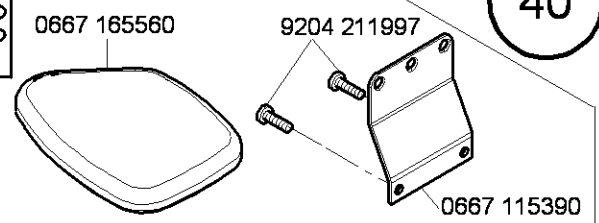
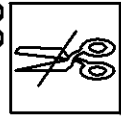

N - nicht als Einzelteil lieferbar
not available as separate part

0867 590014

Cl. 869 -180122
CL.869 -180322

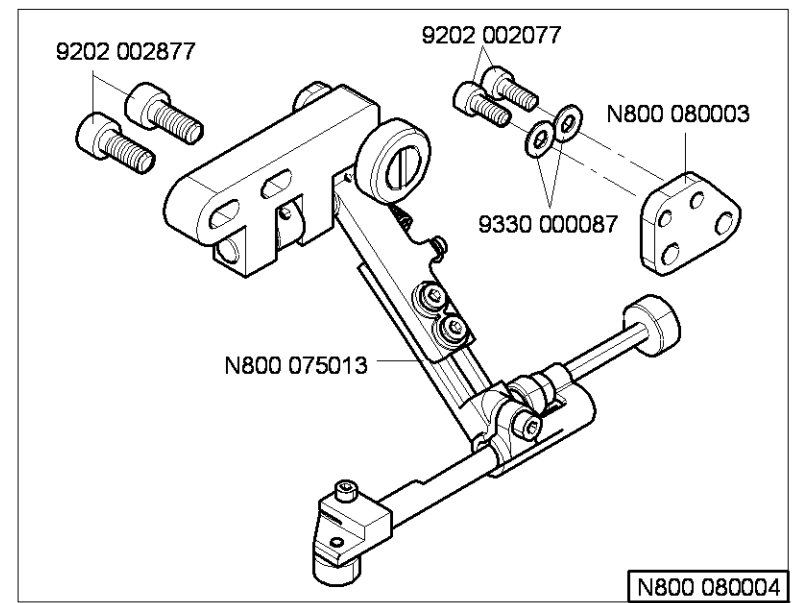
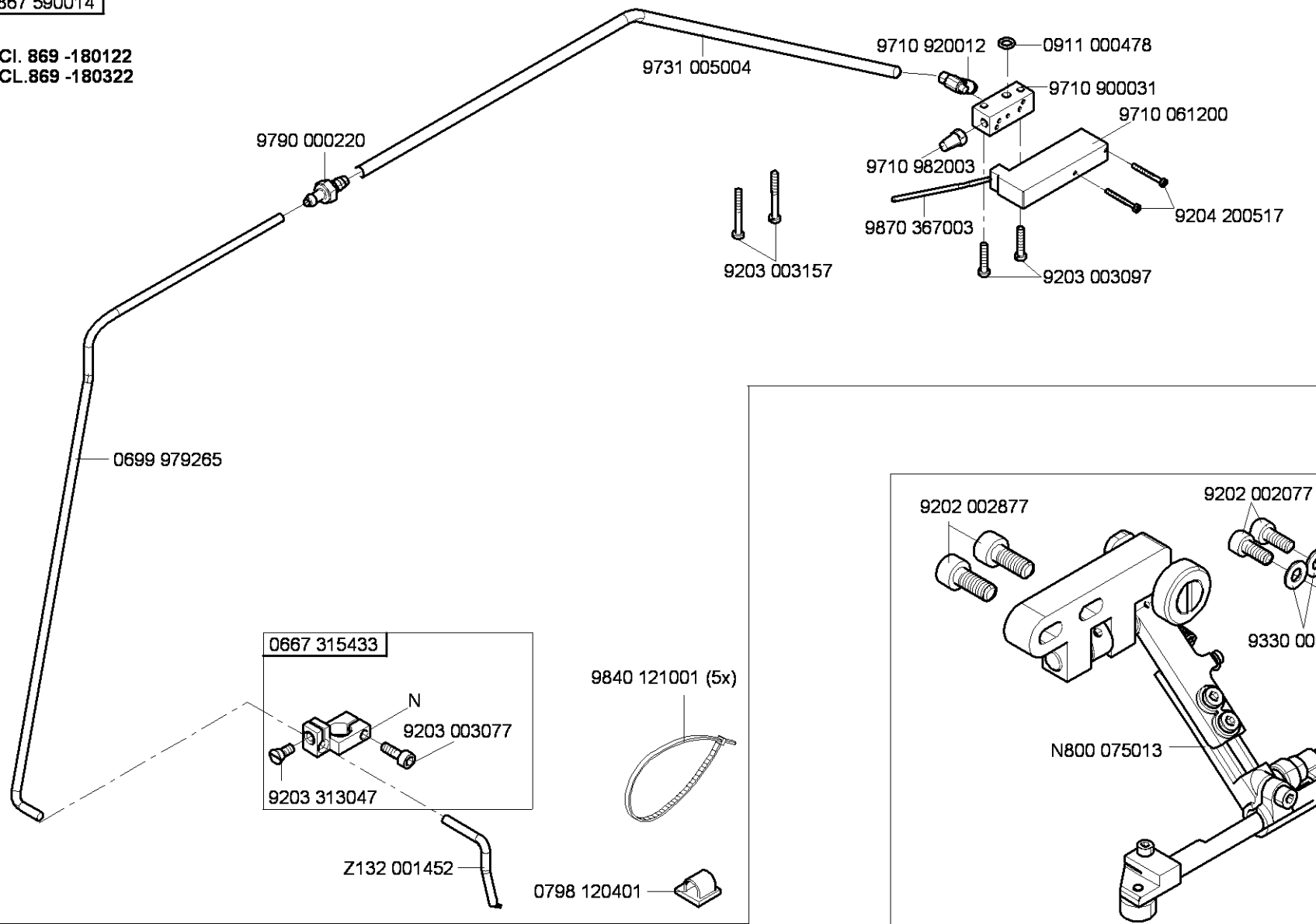

N - nicht als Einzelteil lieferbar
not available as separate part

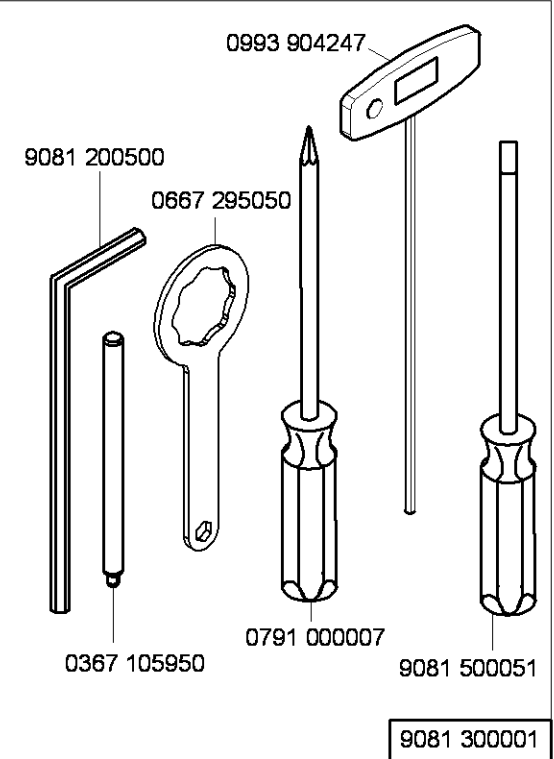
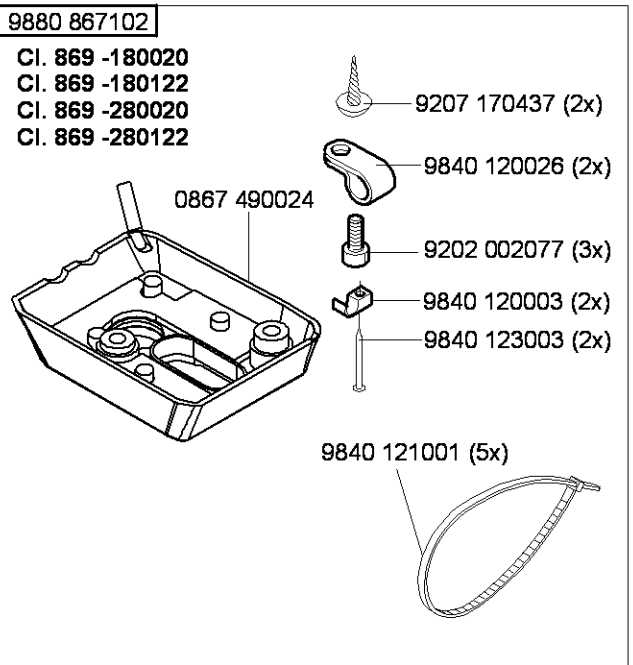
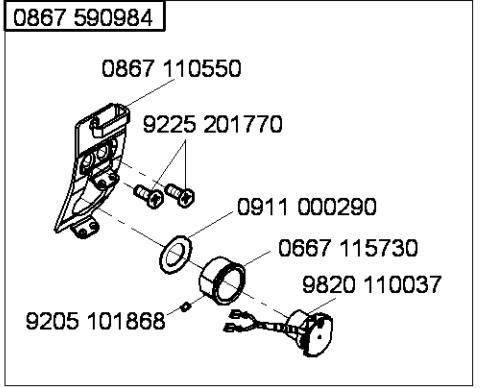
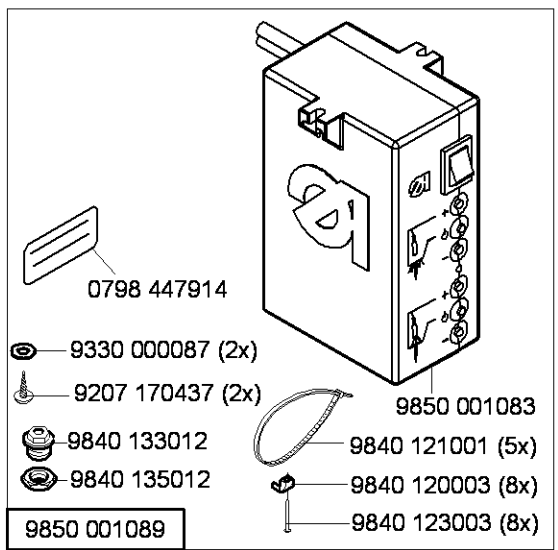
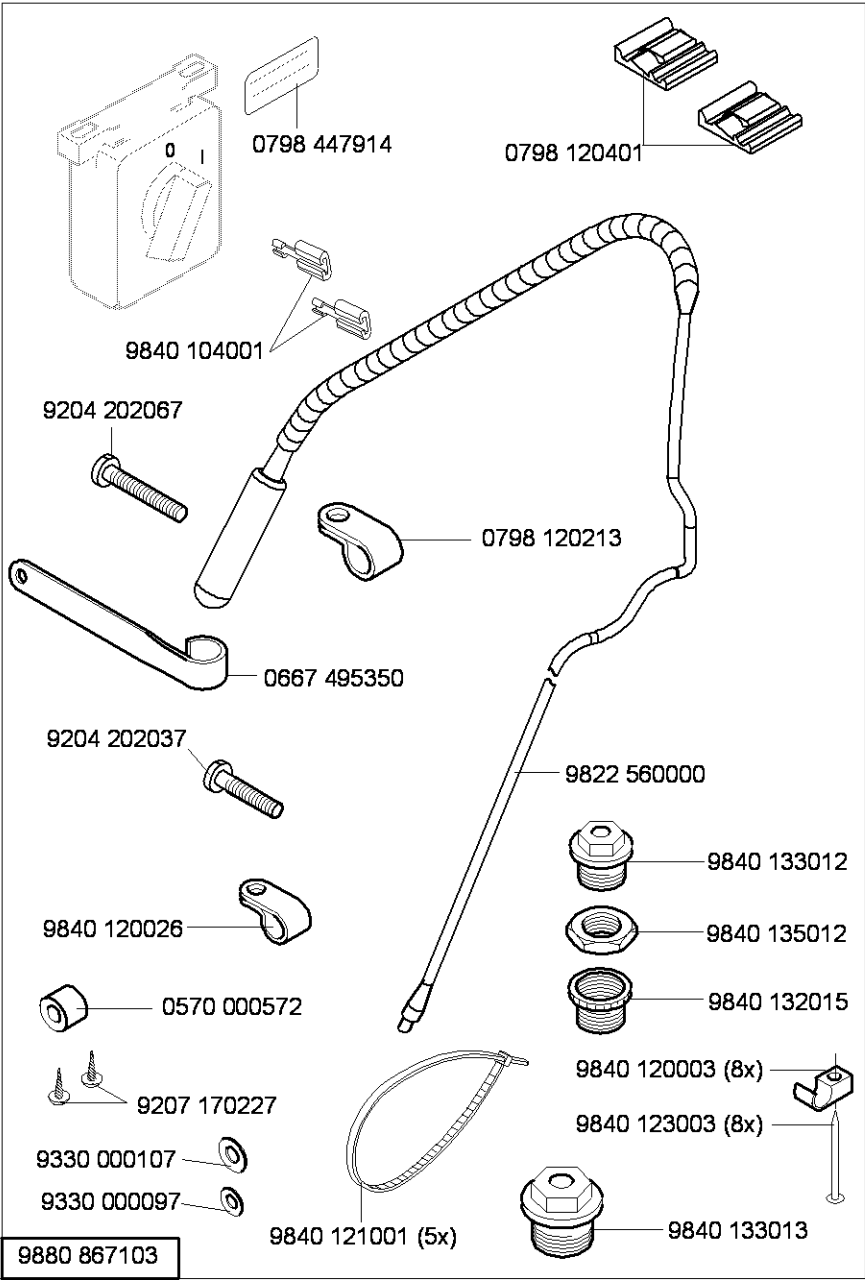

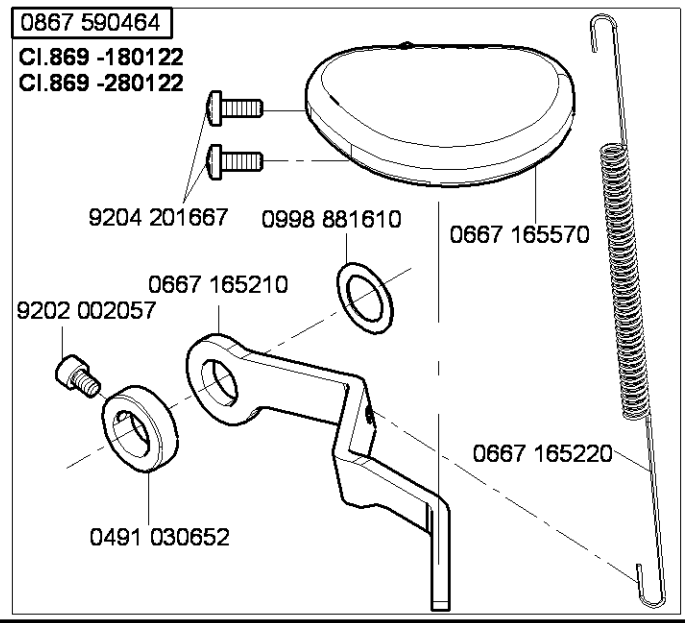
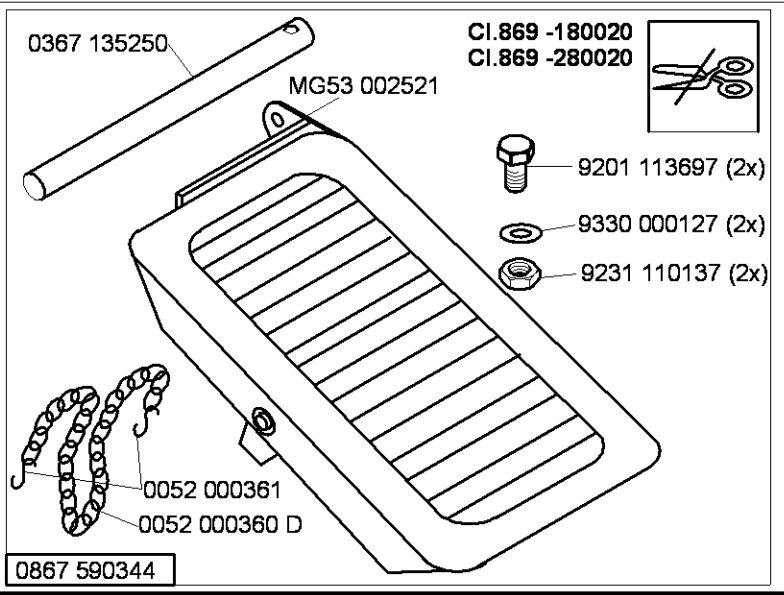
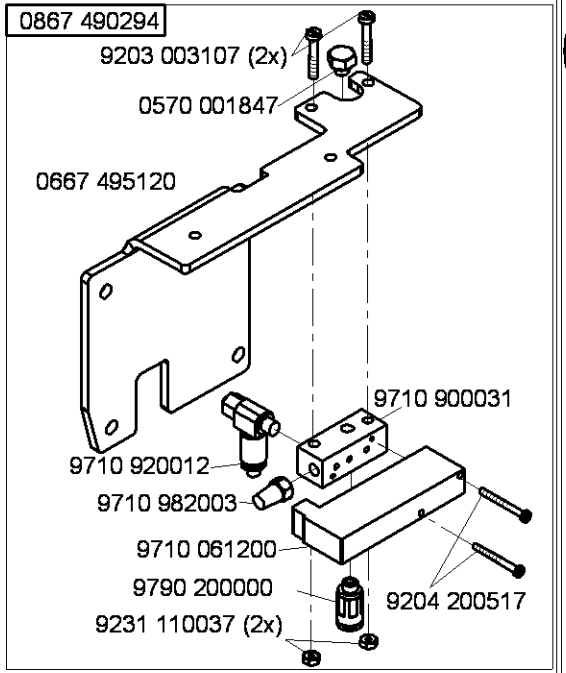
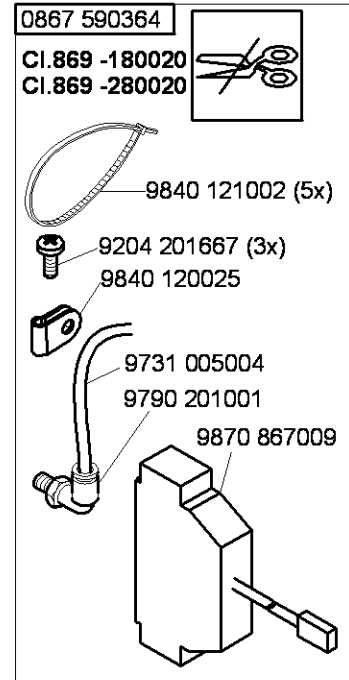
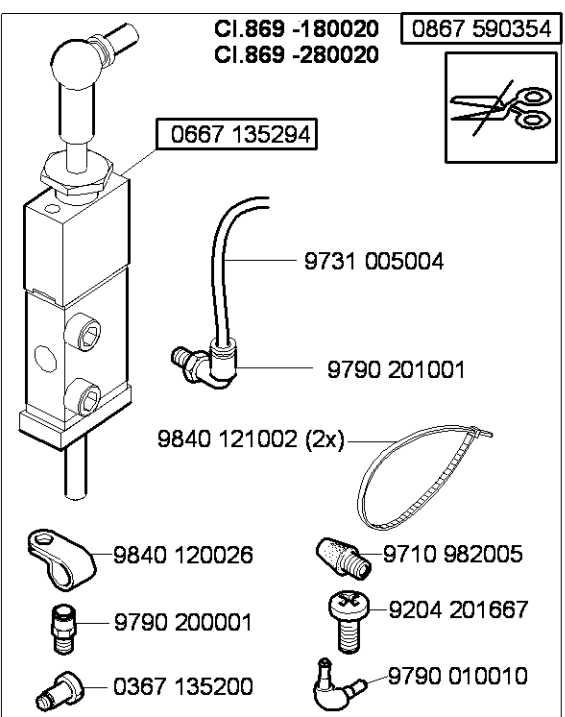
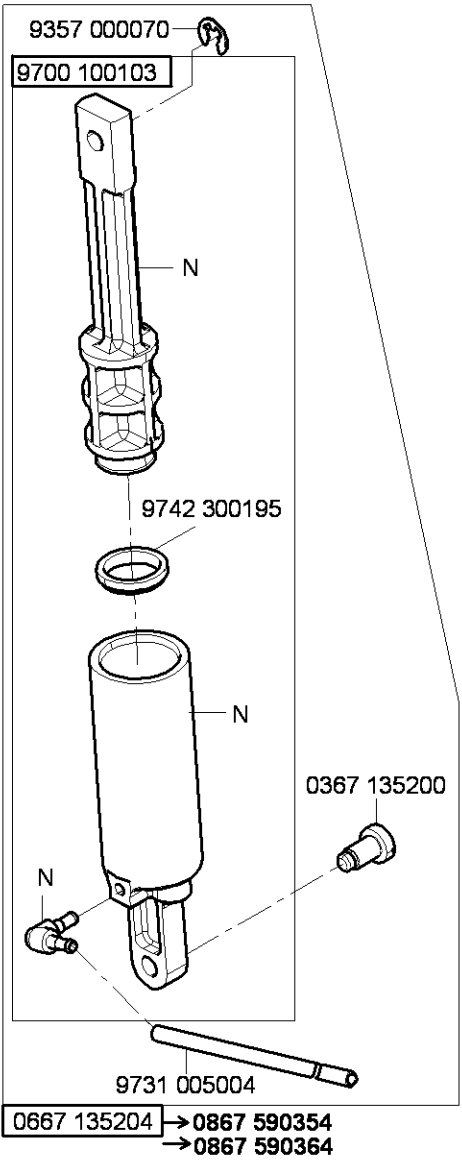

N - nicht als Einzelteil lieferbar
not available as separate part

Teile-Nr./Part-No.	Tafel/Table	Teile-Nr./Part-No.	Tafel/Table	Teile-Nr./Part-No.	Tafel/Table	Teile-Nr./Part-No.	Tafel/Table	Teile-Nr./Part-No.	Tafel/Table
0002 007504 9500	31	0291 000538	24	0467 150130	12	0667 105144	25	0667 115444	17
0031 010320	37	0367 100190	24	0491 030652	21,43	0667 105190	26	0667 115490	16,17
0037 001280	16,17,18,19	0367 105083	5	0556 000821 A	20	0667 105254	26	0667 115514	16
0052 000360 D	43	0367 105180	5	0570 000572	42	0667 105280	2	0667 115520	16,17,18,19
0052 000361	43	0367 105910	31	0570 000623	6	0667 110340	25	0667 115530	16,17,18,19
0053 000350	16,18	0367 105950	42	0570 001847	22,23,43	0667 115070	16,18	0667 115570	18,19
0061 001050	16,17,18,19	0367 110340	16,17,18,19	0659 100010	40	0667 115080	16,18	0667 115580	18,19
0077 110230	39	0367 110360	16,17,18,19	0659 130011	9	0667 115090	16,18	0667 115590	16,17,18,19
0099 004800	40	0367 120100	3	0659 130013	9	0667 115094	18	0667 115600	16,17
0099 004910	16,17,18,19	0367 125020	5	0659 130020	9	0667 115110	18,19	0667 115610	16,17,18,19
0104 250010	39	0367 125194	3	0659 130040	9	0667 115120	16,17,18,19	0667 115620	16,17
0170 100030	29	0367 135200	10,43	0659 130050	9	0667 115130	16,18	0667 115630	16,17,18,19
0211 000085	24	0367 135250	43	0659 130060	9	0667 115134	16,18	0667 115640	16,17,18,19
0211 000699	39	0367 145110	8	0659 130070	9	0667 115140	16,18	0667 115730	42
0212 000541	29,30	0367 145180	5	0659 130084	40	0667 115150	16,18	0667 125060	4
0216 000591	15	0367 150850	24	0659 140100	28	0667 115160	16,18	0667 125100	3
0219 000321	25	0367 165120	5	0659 140110	28	0667 115170	16,17,18,19	0667 125160	3
0223 000450 K	40	0367 165970	11,20	0659 140120	28	0667 115180	16,17	0667 125243	3
0223 000454	40	0367 250020	39	0659 140130	28	0667 115203	16,17,18,19	0667 125250	3
0223 000481	40	0367 315014	5	0659 140140	28	0667 115210	16,17,18,19	0667 125254	3
0223 000483	40	0367 315024	5	0659 380030	24	0667 115220	19	0667 135013	8
0244 000403	15	0367 315130	5	0659 380040	24	0667 115224	19	0667 135033	8
0244 000700	5,8	0367 315223	5	0659 490010	32,33,34	0667 115250	16,17,18,19	0667 135094	8
0245 001660 A	12	0367 315223	8	0659 490030	32,33,34	0667 115280	25	0667 135103	8
0265 000911	16,18	0367 385030	24	0667 100050	3	0667 115290	16,17,18,19	0667 135124	8
0271 000275	15	0367 385133	3	0667 105023	26,27	0667 115320	3	0667 135190	5
0271 001639	20	0367 495010	25	0667 105024	27	0667 115354	17,19	0667 135204	10,43
0281 380114	39	0396 111320	39	0667 105040	1	0667 115360	16,18	0667 135294	43
0291 000159	3	0396 310080	28	0667 105053	1	0667 115390	40	0667 145074	2
0291 000334	20	0467 110220	16,17,18,19	0667 105060	25	0667 115420	16,18	0667 145400	40
0291 000347	25	0467 150040	12	0667 105080	2	0667 115430	16,18	0667 155594	12
0291 000537	24	0467 150120	12	0667 105120	25	0667 115440	17	0667 156190	12

Teile-Nr./Part-No.	Tafel/Table	Teile-Nr./Part-No.	Tafel/Table	Teile-Nr./Part-No.	Tafel/Table	Teile-Nr./Part-No.	Tafel/Table	Teile-Nr./Part-No.	Tafel/Table
0667 156320	12	0667 315053	5	0699 979104	24	0867 110260	18,19	0869 140070	2
0667 160170	20	0667 315113	5	0699 979265	41	0867 110550	42	0869 140113	30
0667 160350	20	0667 315164	5	0699 989250	25,26,27	0867 160620	5,6	0869 140184	2
0667 160374	20	0667 315174	11	0700 000043	35,36,37	0867 160630	5,6	0869 140204	2
0667 160480	5,6	0667 315203	4	0700 000044	35,36,37	0867 160640	5	0869 140210	28
0667 165130	5	0667 315243	4	0700 000045	35,36,37	0867 172110	15	0869 140220	29,30
0667 165151	6	0667 315253	4	0700 000050	35,36,37	0867 172120	15	0869 150023	13
0667 165154	6	0667 315273	5	0700 065901	36	0867 310430	5	0869 150040	13
0667 165190	21	0667 315280	5	0700 065902	35	0867 310440	5	0869 150060	12
0667 165210	21,43	0667 315294	5	0700 065904	37	0867 382030	24	0869 150070	13
0667 165220	21,43	0667 315300	26,27	0742 002096	38	0867 490010	33,40	0869 150090	13
0667 165234	20	0667 315314	5	0744 001155	17,19	0867 490024	25,42	0869 150104	13
0667 165243	20	0667 315320	5	0744 001793 A	38	0867 490294	43	0869 150110	13
0667 165250	20	0667 315330	5	0744 001793 B	38	0867 490380	32,33	0869 150124	13
0667 165260	20	0667 315354	27	0744 001796	38	0867 490400	22,23	0869 150130	13
0667 165284	20	0667 315364	26,27	0767 150590	12	0867 590014	41	0869 150150	13
0667 165560	40	0667 315433	41	0791 000007	42	0867 590344	43	0869 150170	13
0667 165570	21,43	0667 385013	5,6	0791 001081	39	0867 590354	43	0869 150180	12
0667 165694	20	0667 385033	24	0791 001094	39	0867 590364	43	0869 150214	12
0667 170120	15	0667 385143	24	0791 001096	39	0867 590464	43	0869 160010	7
0667 175010	15	0667 385174	24	0791 580100	39	0867 590984	42	0869 160020	7
0667 175020	15	0667 385180	25	0797 003031	38	0868 110054	18,19	0869 160030	7
0667 175030	15	0667 385220	24	0798 000677	32,33,34	0868 310080	5	0869 160040	7
0667 175034	15	0667 495093	23	0798 003292	34	0868 310084	5	0869 160050	7
0667 175040	15	0667 495120	43	0798 120213	42	0868 310090	5	0869 160060	7
0667 175053	15	0667 495290	22,23	0798 120401	41,42	0869 100020	28	0869 160074	7
0667 175060	15	0667 495350	42	0798 447914	31,39,42	0869 100040	28	0869 160080	7
0667 175083	15	0688 130280	8	0798 500088	31	0869 120023	3	0869 160084	7
0667 175104	15	0688 130290	8	0818 160210	6	0869 140030	29	0869 160090	7
0667 235010	3	0688 320630	14	0867 110034	17	0869 140043	29	0869 160100	7
0667 295050	42	0688 320710	5	0867 110064	19	0869 140050	29	0869 160110	7
0667 310563	5	0688 350160	14	0867 110250	16,17	0869 140063	2	0869 160130	7

Teile-Nr./Part-No.	Tafel/Table	Teile-Nr./Part-No.	Tafel/Table	Teile-Nr./Part-No.	Tafel/Table	Teile-Nr./Part-No.	Tafel/Table	Teile-Nr./Part-No.	Tafel/Table
0869 160143	6	0869 350134	14	0999 201114	28	9201 013797	40	9202 150367	24
0869 160153	20	0869 350143	14	0999 210271	7	9201 111257	14	9203 003077	41
0869 160173	7	0869 350150	14	0999 220752	24	9201 113297	32,33,34	9203 003097	22,23,41
0869 160183	6	0869 350160	14	0999 230573	13	9201 113667	40	9203 003107	43
0869 160190	6	0869 350180	14	0999 240408	22	9201 113677	40	9203 003157	41
0869 160200	6	0869 350214	14	9041 100015	5,13,24	9201 113697	37,43	9203 100002	16,17,18,19
0869 160210	6	0869 350220	14	9041 100025	3	9202 001678	3,15	9203 100617	32,33,34
0869 160220	6	0869 350230	14	9041 100030	24	9202 002057	5,6,14,21,43	9203 211830	12
0869 160234	20	0869 350240	7	9041 100035	24	9202 002067	6,24	9203 312412	3
0869 160280	6	0869 350250	14	9041 100203	24,39	9202 002077	25,31,41,42	9203 313022	7
0869 160293	6	0869 350280	14	9081 200303	39	9202 002078	3,20	9203 313047	41
0869 160324	6	0869 350290	14	9081 200500	42	9202 002087	21,32,33,34	9203 361828	14
0869 160374	20	0869 350300	14	9081 300001	42	9202 002097	20,31	9204 001257	29,30
0869 160384	20	0869 350313	14	9081 500010	39	9202 002098	4,6,8,20	9204 001767	30
0869 160400	6	0869 380010	24	9081 500051	42	9202 002117	14	9204 101657	5
0869 160410	7	0869 380030	24	9122 200161	1	9202 002497	13	9204 101677	29
0869 160420	7	0869 380040	24	9122 322200	4	9202 002877	41	9204 200447	22
0869 310013	4	0869 380060	24	9126 100050	7	9202 002888	20	9204 200517	22,23,41,43
0869 310023	4	0902 000423	29,30	9126 102520	5,20	9202 002918	5	9204 201067	15,22,23
0869 350010	14	0907 020270	37	9126 102530	6	9202 002927	8,38	9204 201067	22
0869 350020	14	0911 000290	42	9126 102540	5,6,20	9202 003027	37	9204 201067	23
0869 350033	14	0911 000478	22,23	9126 108120	7,14	9202 003187	28	9204 201647	16,17,18,19,25, 28,32,33
0869 350040	14	0911 000478	41	9126 116180	6	9202 003738	25	9204 201657	3,24,32,33,34
0869 350044	14	0933 001544	24	9126 300201	4	9202 012040	7	9204 201667	3,15,21,22,23,43
0869 350050	14	0992 016580	12	9129 024235	3	9202 021648	13	9204 201697	24
0869 350060	14	0992 023560	12	9130 104070	32,33,34	9202 022078	14	9204 201698	39
0869 350070	14	0992 023577	12	9130 221100	2	9202 022477	32,33	9204 201727	9
0869 350080	14	0993 904247	42	9130 500750	32,33,34	9202 022497	34	9204 201827	16,17,18,19
0869 350090	14	0995 340617	39	9190 100108	25	9202 100357	7	9204 202037	42
0869 350100	14	0998 881610	5,21,43	9190 100155	26,27,29,30	9202 100537	7	9204 202067	42
0869 350110	14	0998 881630	6	9190 400120	20	9202 100957	28		
0869 350123	14	0998 882510	16,17,18,19	9199 000004	23	9202 150317	14		

Teile-Nr./Part-No.	Tafel/Table	Teile-Nr./Part-No.	Tafel/Table	Teile-Nr./Part-No.	Tafel/Table	Teile-Nr./Part-No.	Tafel/Table	Teile-Nr./Part-No.	Tafel/Table
9204 211997	2,5,20,25,26,27, 33,40	9225 201790	24	9334 001170	7	9710 982006	22,23	9815 301096	23
		9231 000377	13	9334 001630	3,4,5,15,20,28	9731 001035	24	9815 310008	23
9204 212057	25,28,40	9231 000387	8	9334 001640	4	9731 002001	38	9815 310009	23
9204 301467	23	9231 011137	40	9352 000163	6	9731 005004	10,11,14,17,19, 20,21,22,23,41,43	9820 110037	42
9204 301487	15	9231 110037	15,43	9352 600118	37			9822 510003	31
9204 302217	11,20,21	9231 110057	24	9353 000280	2	9731 007035	3,24	9822 510013	31
9204 431657	17,19	9231 110137	37,43	9353 000320	2	9740 000607	26,27	9822 560000	42
9205 101847	3	9234 000067	20	9353 000470	1,2	9742 300150	14	9822 610000	31
9205 101868	14,42	9234 000087	28	9354 010210	2	9742 300190	11	9822 642027	31
9205 102148	7,14	9301 102203	5	9354 400800	24	9742 300195	10,43	9825 810302	31
9205 102158	13,14	9301 102821	29,30	9354 401310	7	9780 000108	38	9825 810417	34
9205 102168	7,13	9302 000100	24	9357 000060	4	9790 000220	41	9830 501010	22,23
9205 102303	5	9305 100350	16,17	9357 000070	5,9,10,11,15,20, 28,43	9790 010010	14,43	9840 104001	31,42
9205 102450	7	9305 100370	18,19			9790 020010	19	9840 120001	32,33,34
9205 102467	1,2,4,5,6,7,8,11, 13,14,15,20,28	9330 000067	14,16,17,18,19	9357 000080	16,18,20	9790 200000	22,23,43	9840 120003	11,25,31,32,33, 39,42
9205 102477	2,3,5,9,12,16, 18,20	9330 000087	3,4,6,16,17,18,19, 20,32,33,34,39, 41,42	9357 000090	4,5,7	9790 200001	43	9840 120025	11,32,33,34,43
9205 102787	40	9330 000097	2,40,42	9357 000100	9,20,28	9790 201000	22,23	9840 120026	25,31,42,43
9206 100637	24			9357 000120	5,20	9790 201001	40,43	9840 120027	24
9206 200087	37	9330 000107	32,33,34,42	9380 521220	40	9800 130104 R	34	9840 120027	24
9206 200097	37	9330 000127	28,35,36,37,43	9401 000140	28	9800 130105	34	9840 120030	39
9207 170227	32,33,34,35,36, 37,42	9330 000177	39	9401 000194	32,33	9800 170040	32,33	9840 120060	32,33,34
		9330 000177	39	9401 000204	32,33	9800 210001 R	33	9840 120104	24
9207 170437	25,31,32,33,39,42	9330 200097	14	9700 100094	11	9800 210002 R	32	9840 120105	21,24
9207 170847	37	9330 200107	13	9700 100100	20,21	9800 327007	32,33	9840 121001	11,25,31,39,41,42
9207 170857	32,33,34,36,37	9330 200117	28	9700 100103	10,43	9800 330009	34	9840 121002	43
9207 171057	35,36	9330 700107	26,27	9710 061200	22,23,41,43	9800 330010	34	9840 123002	32,33
9217 300517	7	9330 900117	28,35,36,37	9710 900011	22	9800 330012	34	9840 123003	11,25,31,32,33, 34,39,42
9225 201240	14	9330 900127	40	9710 900031	22,23,41,43	9800 331104	34	9840 130007	24
9225 201750	3	9330 900137	36	9710 900047	22,23	9815 301079	23	9840 132015	31,42
9225 201770	16,17,18,19,25, 31,42	9332 500137	16,17,18,19	9710 920012	22,23,41,43	9815 301081	23	9840 133012	31,39,42
		9333 000090	28	9710 982003	22,23,41,43	9815 301090	23	9840 133013	31,42
		9334 001150	14	9710 982005	43	9815 301091	23		



E1/6
E2/9

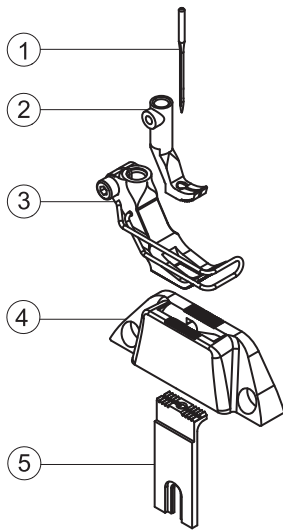

E7/6

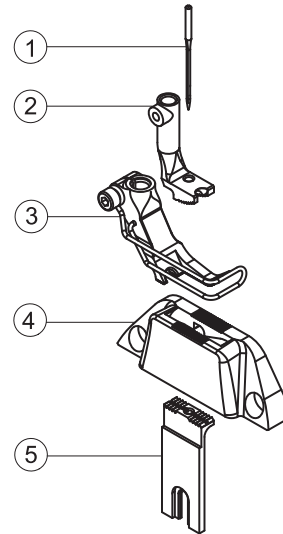

E10/5

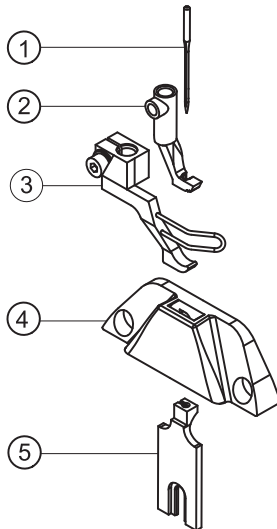

E11/9

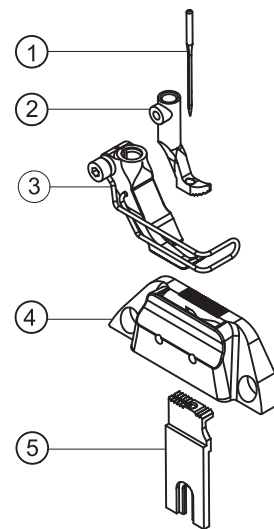

E14/6

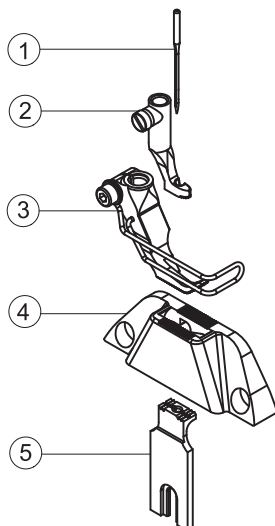

E16/6

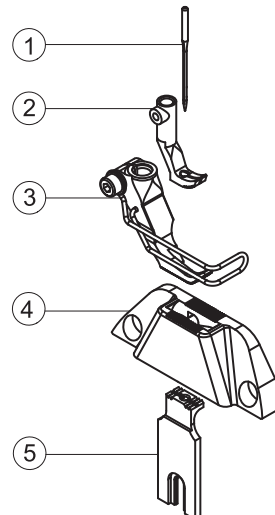



E50/6

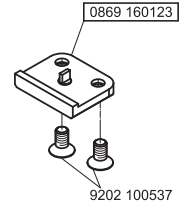
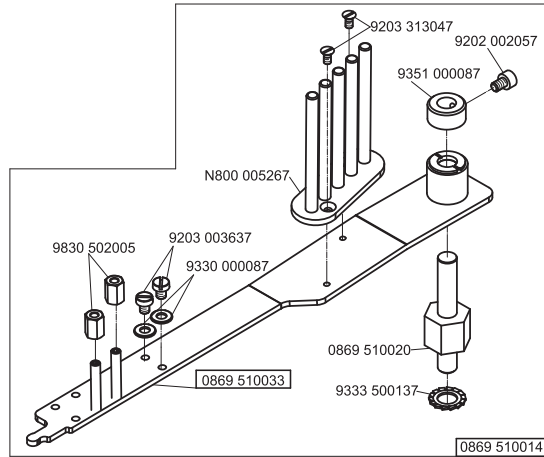
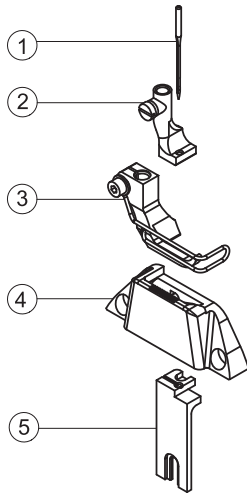



E21/6/6
E21/6/9

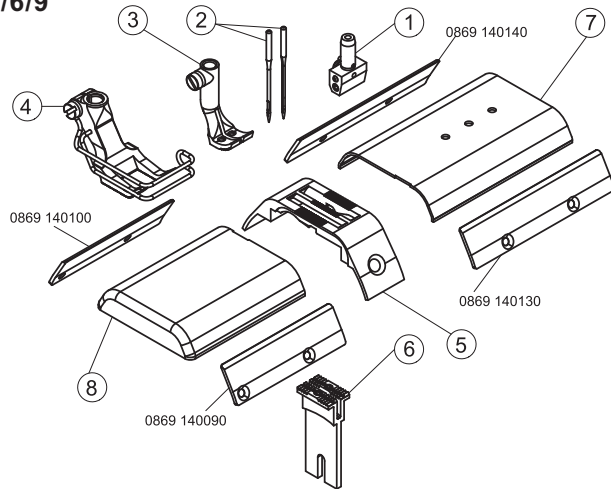

E21/8/6
E21/8/9

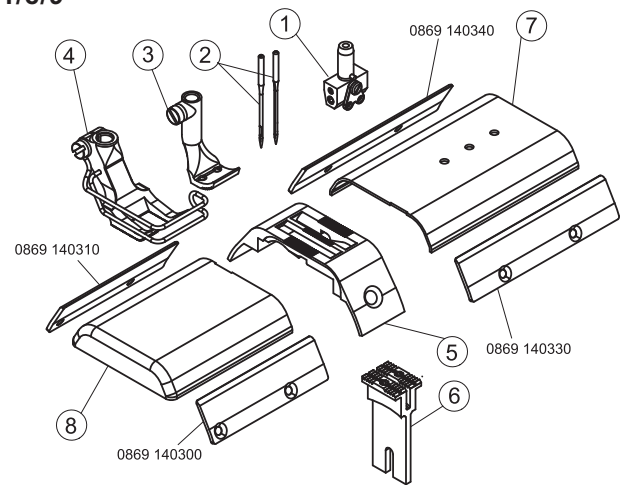

E21/10/6
E21/10/9

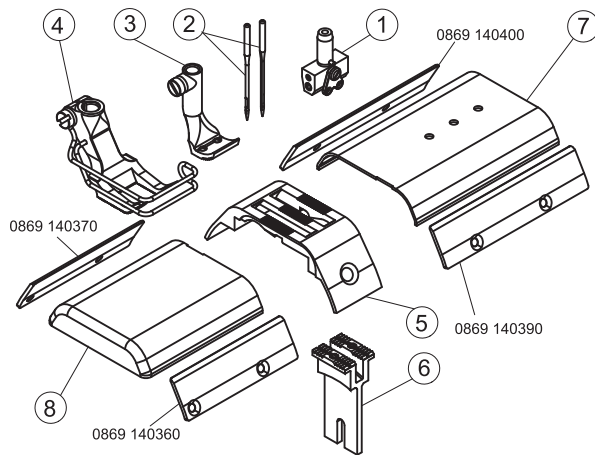

E21/12/6
E21/12/9

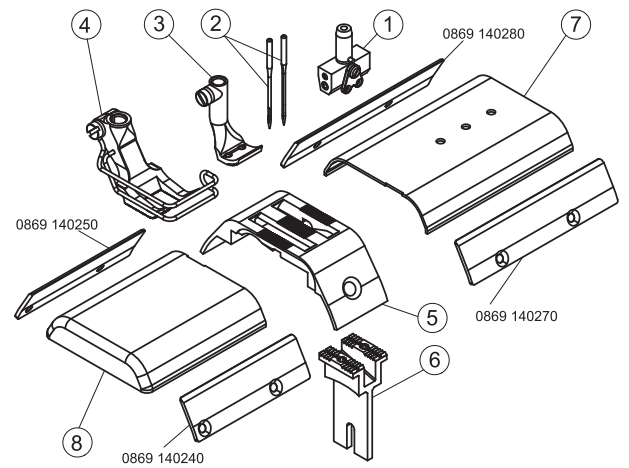

E21/14/6
E21/14/9

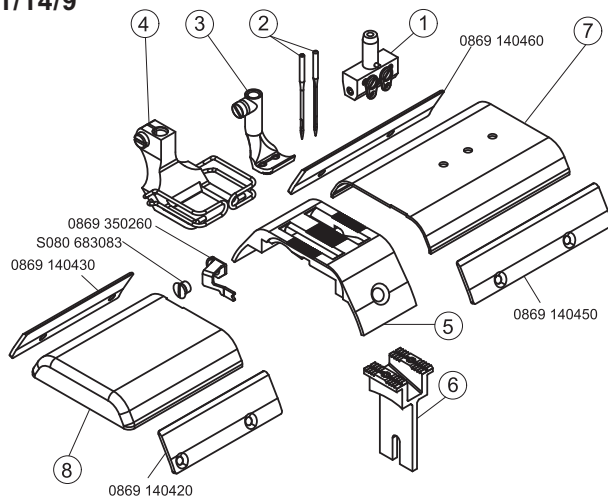



E-Nr. E-No.	Für Unterklasse / For Subclass	Abb.-Nr. Fig.No.	Verwendungszweck / Use	Material No. / Material Nr.	Stichplatte	Transporteur	Presserfuß	Transp. Fuß												
					Throat plate	Feed dog	Presser foot	Feeding foot												
					④		③	②												①
E1/6	-180020; -180122; -180322 Näheinrichtung, Nadelstärke Nm 110-140, Stichlänge max. 6 mm, für mittelschweres Nähgut, Transporteurbreite 6 mm. Sewing equipment, needle size Nm 110-140, stitch length max. 6 mm, for medium weight material, width feeder 6 mm.			0869 E00106	0869 200010															134-35/130
E7/6	-180020; -180122; -180322 Näheinrichtung für Kedararbeiten, Kedernut 5 mm, Nadelstärke Nm 110-140, Stichlänge max. 6 mm, für mittelschweres Nähgut, Transporteurbreite 6 mm. Sewing equipment for welt attaching operations, welt groove 5 mm, needle size Nm 110-140, stitch length max. 6 mm, for medium weight material, width feeder 6 mm.			0869 E00706	0869 200010															134-35/130
E10/5	-180020; -180122; -180322 Näheinrichtung, Nadelstärke Nm 100-120, Stichlänge max. 5 mm, für mittelschweres Nähgut, Transporteurbreite 5 mm. Sewing equipment, needle size Nm 100-120, stitch length max. 5 mm, for medium weight material, width feeder 5 mm.			0869 E01005	0869 200120															134-35/110
E11/9	-180020; -180122; -180322 Näheinrichtung für Kantennäharbeiten ab 1 mm rechts der Nadel, Nadelstärke Nm 110-140, Stichlänge max. 9 mm, für mittelschweres Nähgut, Transporteurbreite 5 mm. Sewing equipment for stitching on edges, from 1 mm on the right from the needle, needle size Nm 110-140, stitch length max. 9 mm, for medium weight material, width feeder 5 mm.			0869 E01109	0869 200130															134-35/130



E-Nr. E-No.	Für Unterklasse / For Subclass	Abb.-Nr. Fig.No.	Verwendungszweck / Use	Material No. / Material Nr.	Stichplatte Throat plate			Transporteur Feed dog			Presserfuß Presser foot			Transp. Fuß Feeding foot				
					④ Stichplatte / Throat plate	Schieber, links / Slide, left	Schieber, rechts / Slide, right	Stichlochgröße / Stich hole size mm	Sägeverzahn / Serrated mm	Säge-schrägverzahn / Serrated, oblique mm	Kreuzverzahn / Cross toothed mm	Drückerfuß / Presser foot	Unverzahn / Non toothed	Hüpfenfuß, kreuzverz. / Skipping f., cross toothed	Ausgleichfuß / Compensating foot	Kreuzverzahn / Cross toothed mm	Unverzahn / Non toothed	Stichplattenthalter/Throat plate holder
E14/6	-180020; -180122; -180322 Näheinrichtung für Kantennäharbeiten für enge Radien ab 1 mm rechts der Nadel, Nadelstärke Nm 110-140, Stichtlänge max. 6 mm, für mittelschweres Nähgut, Transporteurbreite 6 mm. Sewing equipment for stitching on edges for thin radius from 1 mm on the right from the needle, needle size Nm 110-140, stitch length max. 6 mm, for medium weight material, width feeder 6 mm.			0869 E01406	0869 200040			Ø 2,5	0869 210040			0659 220033			0069 221143			134-35/130
E16/6	-180020; -180122; -180322 Näheinrichtung für Kantennäharbeiten mit kurzem Transporteur, Nadelstärke Nm 110-140, Stichtlänge max. 6 mm, für mittelschweres Nähgut, Transporteurbreite 6 mm. Sewing equipment for stitching on edges with short feeder, needle size Nm 110-140, stitch length max. 6 mm, for medium weight material, width feeder 6 mm.			0869 E01606	0869 200040			Ø 2,5	0869 210040			0659 220013			0067 220633			134-35/130
E2/9	-180020; -180122; -180322 Näheinrichtung für Kantennäharbeiten, Nadelstärke Nm 110-140, Stichtlänge max. 9 mm, für mittelschweres Nähgut, Transporteurbreite 8 mm. Sewing equipment for stitching on edges, needle size Nm 110-140, stitch length max. 9 mm, for medium weight material, width feeder 8 mm.			0869 E00209	0869 200050			Ø 2,5	0869 210050			0467220043			0467 220013			134-35/130
E50/6	-180020; -180122; -180322 Näheinrichtung zum Einfassen, Nadelstärke Nm 110-140, Stichtlänge max. 6 mm, für mittelschweres Nähgut. Sewing equipment for facing, needle size Nm 100-140, stitch length max. 6 mm, for medium weight material.			0869 E05006	0869 200030			Ø 2,5	0869 210030			0869 220013			0869 220023			134-35/130



E-Nr. E-No.	Für Unterklasse / For Subclass	Abb.-Nr. Fig.No.	Verwendungszweck / Use	Material No. / Material Nr.	Stichplatte	Transporteur	Presserfuß	Transp.	Nadelabstand / Needle distance	Nadelhalter / Needle holder	Nadelsystem / -dicke / Needle system / -size			
					Throat plate	Feed dog	Presser foot	Feeding foot						
					⑤	⑧	⑦	⑥	④	③	①	②		
E21/6/6	-280020; -280122; -280322 Näheinrichtung, Nadelabstand 6 mm, Nadelstärke Nm 110-140, Stichtlänge max. 6 mm, für mittelschweres Nähgut. Sewing equipmen, needle gauge 6 mm, needle size Nm 110-140, stitch length max. 6 mm, for medium weight material.			0869 E02106 6	0869 200190	0869 140080	0869 140150	2,2 x 3,2	0869 210020	0367 222093	0067 222343	6	0867 230134	134-35/130
E21/8/6	-280020; -280122; -280322 Näheinrichtung, Nadelabstand 8 mm, Nadelstärke Nm 110-140, Stichtlänge max. 6 mm, für mittelschweres Nähgut. Sewing equipmen, needle gauge 8 mm, needle size Nm 110-140, stitch length max. 6 mm, for medium weight material.			0869 E02106 8	0869 200200	0869 140320	0869 140350	2,2 x 3,2	0869 210060	0367 222103	0067 222353	8	0867 230144	134-35/130
E21/10/6	-280020; -280122; -280322 Näheinrichtung, Nadelabstand 10 mm, Nadelstärke Nm 110-140, Stichtlänge max. 6 mm, für mittelschweres Nähgut. Sewing equipmen, needle gauge 10 mm, needle size Nm 110-140, stitch length max. 6 mm, for medium weight material.			0869 E02106 10	0869 200160	0869 140380	0869 140410	2,2 x 3,2	0869 210070	0367 222013	0067 222383	10	0867 230154	134-35/130
E21/12/6	-280020; -280122; -280322 Näheinrichtung, Nadelabstand 12 mm, Nadelstärke Nm 110-140, Stichtlänge max. 6 mm, für mittelschweres Nähgut. Sewing equipmen, needle gauge 12 mm, needle size Nm 110-140, stitch length max. 6 mm, for medium weight material.			0869 E02106 12	0869 200170	0869 140260	0869 140290	2,2 x 3,2	0869 210080	0367 222313	0067 222393	12	0867 230164	134-35/130
E21/14/6	-280020; -280122; -280322 Näheinrichtung, Nadelabstand 14 mm, Nadelstärke Nm 110-140, Stichtlänge max. 6 mm, für mittelschweres Nähgut. Sewing equipmen, needle gauge 14 mm, needle size Nm 110-140, stitch length max. 6 mm, for medium weight material.			0869 E02106 14	0869 200180	0869 140440	0869 140470	2,2 x 3,2	0869 210090	0367 222323	0067 222413	14	0867 230174	134-35/130



E-Nr. E-No.	Für Unterklasse / For Subclass	Abb.-Nr. Fig.No.	Verwendungszweck / Use	Material No. / Material Nr.	Stichplatte	Transporteur	Presserfuß	Transp.	Nadelabstand / Needle distance	Nadelhalter / Needle holder	Nadelsystem / -dicke / Needle system / -size										
					Throat plate	Feed dog	Presser foot	Feeding foot													
					⑤	⑧	⑦	⑥	④	③	①	②									
					Stichplatte / Throat plate	Schieber, links / Slide, left	Schieber, rechts / Slide, right	Stichlochgröße / Stich hole size mm	Sägeverzahnung / Serrated	Sägeverzahnung / Serrated	Kreuzverzahnung / Cross toothed	Drückerfuß / Presser foot	Unverzahnung / Non toothed	Hüpfenfuß, kreuzverz. / Skipping f., cross toothed	Ausgleichfuß / Compensating foot	Kreuzverzahnung / Cross toothed	Unverzahnung / Non toothed				
E21/6/9	-280020; -280122; -280322 Näheinrichtung, Nadelabstand 6 mm, Nadelstärke Nm 110-140, Stichtlänge max. 9 mm, für mittelschweres Nähgut. Sewing equipmen, needle gauge 6 mm, needle size Nm 110-140, stitch length max. 9 mm, for medium weight material.			0869 E02109 6	0869 200020	0869 140080	0869 140150	2,2 x 3,2	0869 210020			0367 222573				0067 222343			6	0867 230134	134-35/130
E21/8/9	-280020; -280122; -280322 Näheinrichtung, Nadelabstand 8 mm, Nadelstärke Nm 110-140, Stichtlänge max. 9 mm, für mittelschweres Nähgut. Sewing equipmen, needle gauge 8 mm, needle size Nm 110-140, stitch length max. 9 mm, for medium weight material.			0869 E02106 8	0869 200060	0869 140320	0869 140350	2,2 x 3,2	0869 210060			0869 220113				0067 222353			8	0867 230144	134-35/130
E21/10/9	-280020; -280122; -280322 Näheinrichtung, Nadelabstand 10 mm, Nadelstärke Nm 110-140, Stichtlänge max. 9 mm, für mittelschweres Nähgut. Sewing equipmen, needle gauge 10 mm, needle size Nm 110-140, stitch length max. 9 mm, for medium weight material.			0869 E02109 10	0869 200070	0869 140380	0869 140410	2,2 x 3,2	0869 210070			0367 223433				0067 222383			10	0867 230154	134-35/130
E21/12/9	-280020; -280122; -280322 Näheinrichtung, Nadelabstand 12 mm, Nadelstärke Nm 110-140, Stichtlänge max. 9 mm, für mittelschweres Nähgut. Sewing equipmen, needle gauge 12 mm, needle size Nm 110-140, stitch length max. 9 mm, for medium weight material.			0869 E02109 12	0869 200080	0869 140260	0869 140290	2,2 x 3,2	0869 210080			0367 222583				0067 222393			12	0867 230164	134-35/130
E21/14/9	-280020; -280122; -280322 Näheinrichtung, Nadelabstand 14 mm, Nadelstärke Nm 110-140, Stichtlänge max. 9 mm, für mittelschweres Nähgut. Sewing equipmen, needle gauge 14 mm, needle size Nm 110-140, stitch length max. 9 mm, for medium weight material.			0869 E02109 14	0869 200090	0869 140440	0869 140470	2,2 x 3,2	0869 210090			0367 223003				0067 222413			14	0867 230174	134-35/130

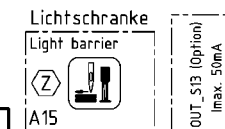
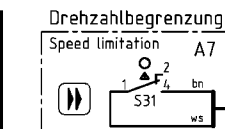
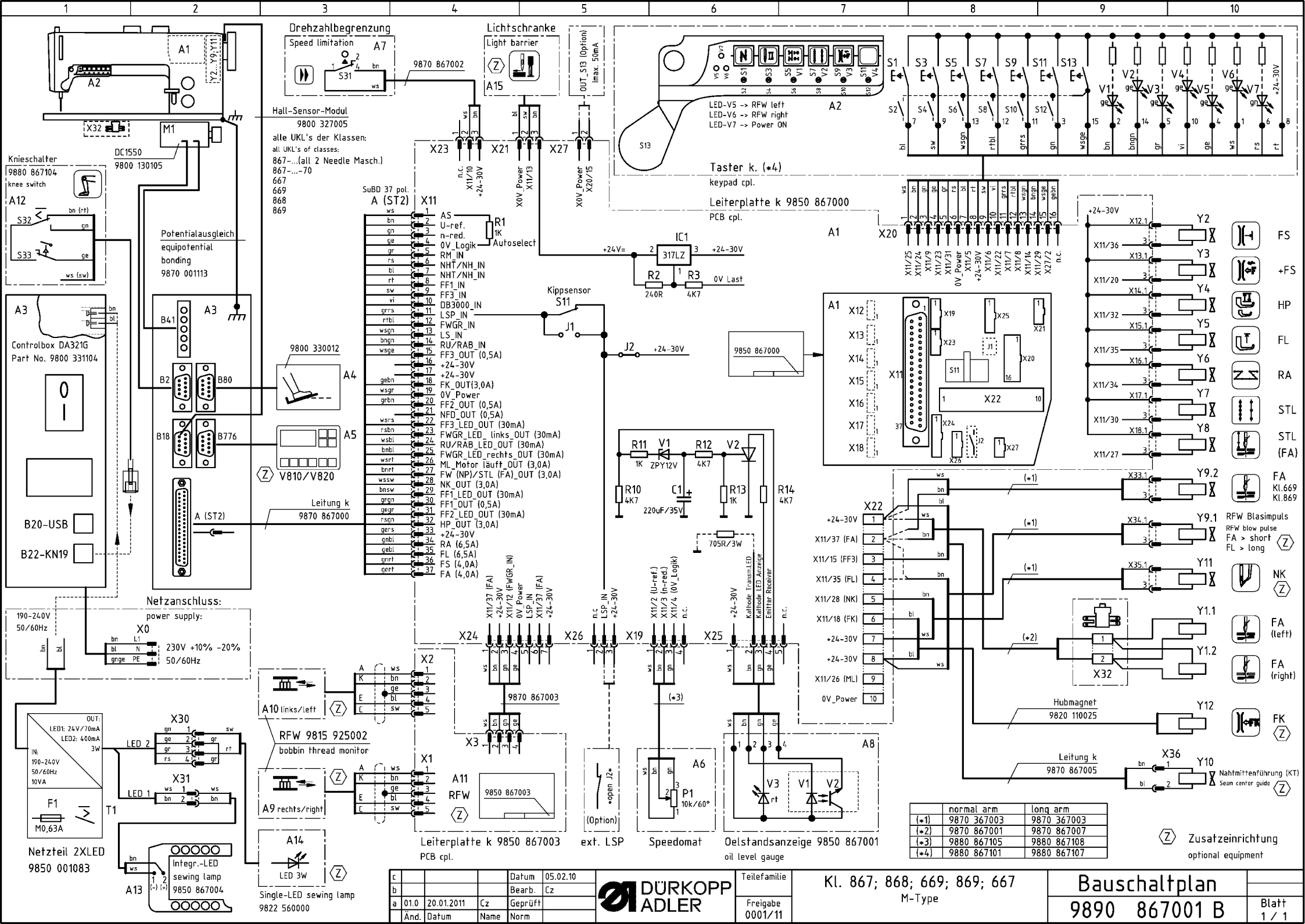

Hall-Sensor-Modul
9800 327005

alle UKL's der Klassen:
all UKL's of classes:
867... (all 2 Needle Masch.)
867...-70
667
669
868
869

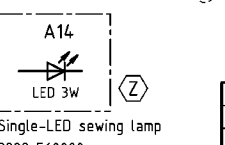
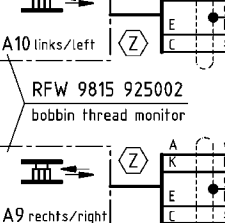
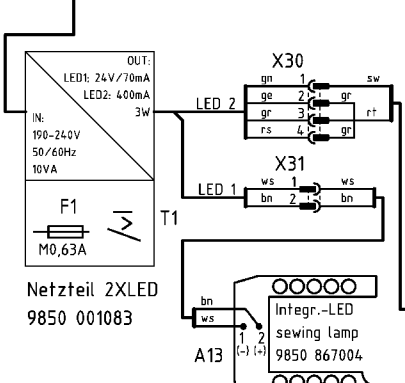
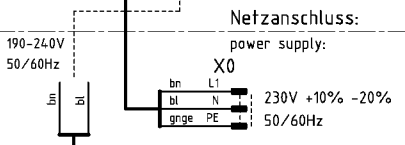
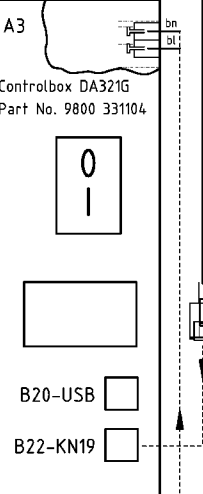
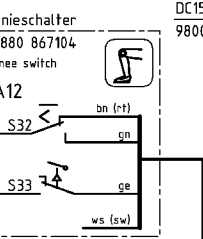
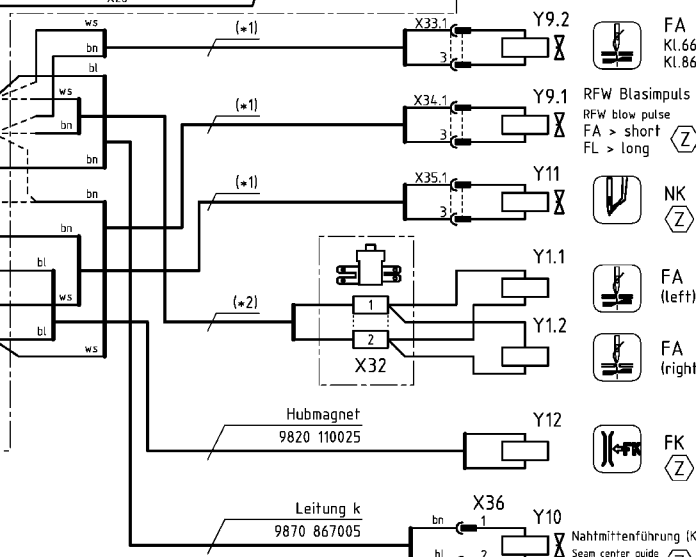
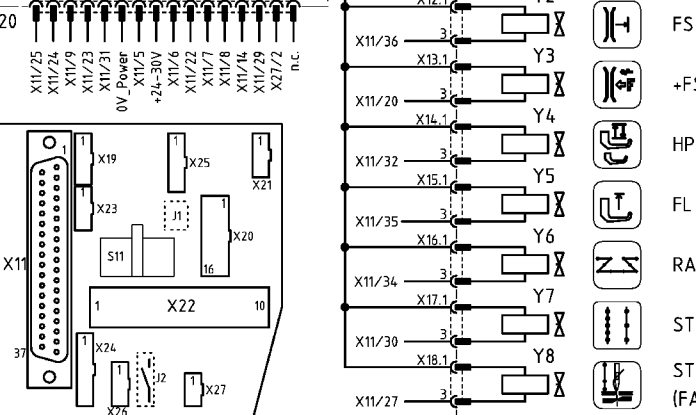
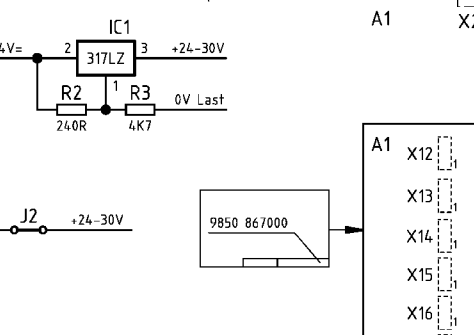
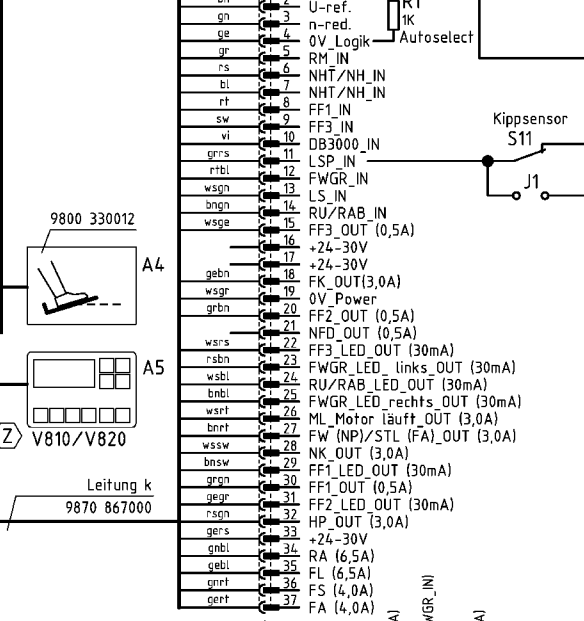
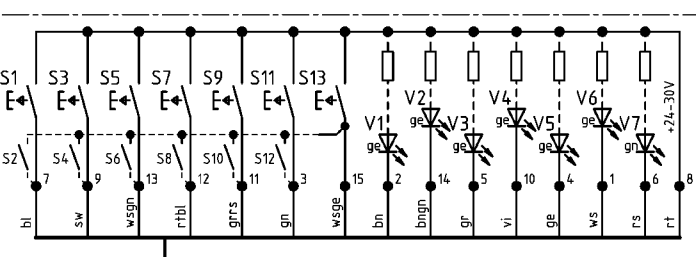
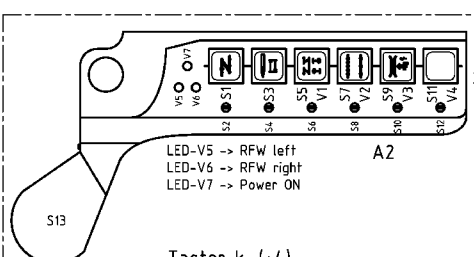

Leiterplatte k 9850 867003
PCB cpl.

Leiterplatte k 9850 867000
PCB cpl.

	normal arm	long arm
(*1)	9870 367003	9870 367003
(*2)	9870 867001	9870 867007
(*3)	9880 867105	9880 867108
(*4)	9880 867101	9880 867107

(Z) Zusatzeinrichtung
optional equipment

c		Datum	05.02.10
b		Bearb.	Cz
a	01.0	20.01.2011	Cz
Änd.	Datum	Name	Norm

DURKOPP ADLER

Teilefamilie
Freigabe 0001/11

Kl. 867; 868; 669; 869; 667
M-Type

Bauschaltplan
9890 867001 B
Blatt 1 / 1

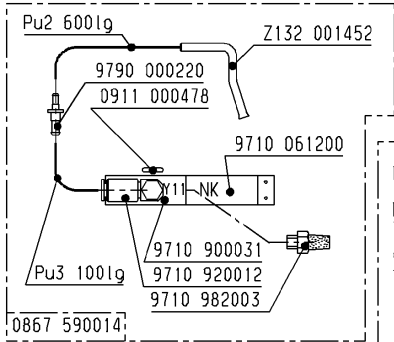
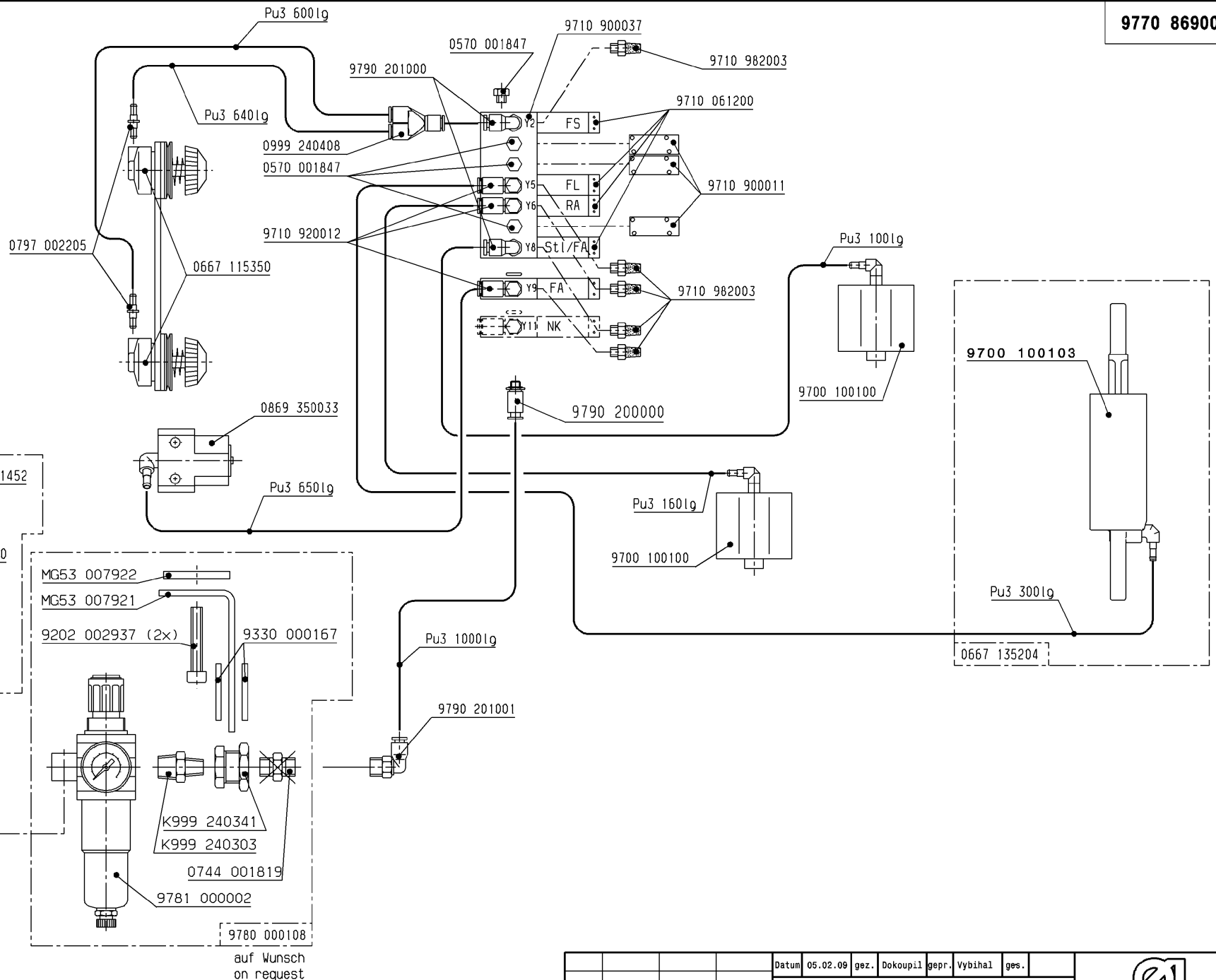

auf Wunsch
on request

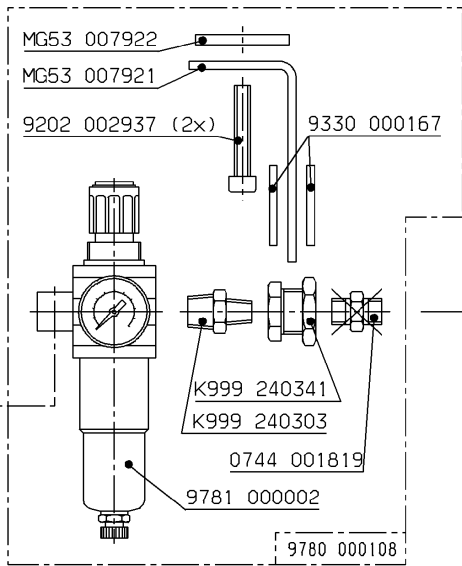

auf Wunsch
on request

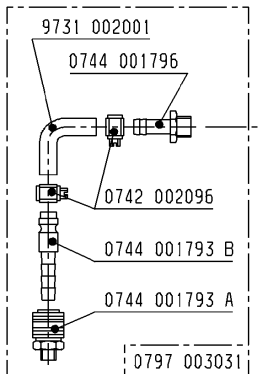

auf Wunsch
on request

Schlauch Hose	Teile-Nr. (Meterware) Part-No. (Yarded goods)
PU2	0699 979265
PU3	9731 005004

Datum	05.02.09	gez.	Dokoupil	gepr.	Vybihal	ges.
Pneu.-Geräteplan für Pneu.-Elements-Plan for 0869-180122 und 0869-280122						
Änd.	Datum	gez.	gepr.			

DÜRKOPP ADLER AG
9770 869001
 Blatt 1 Blattz. 2

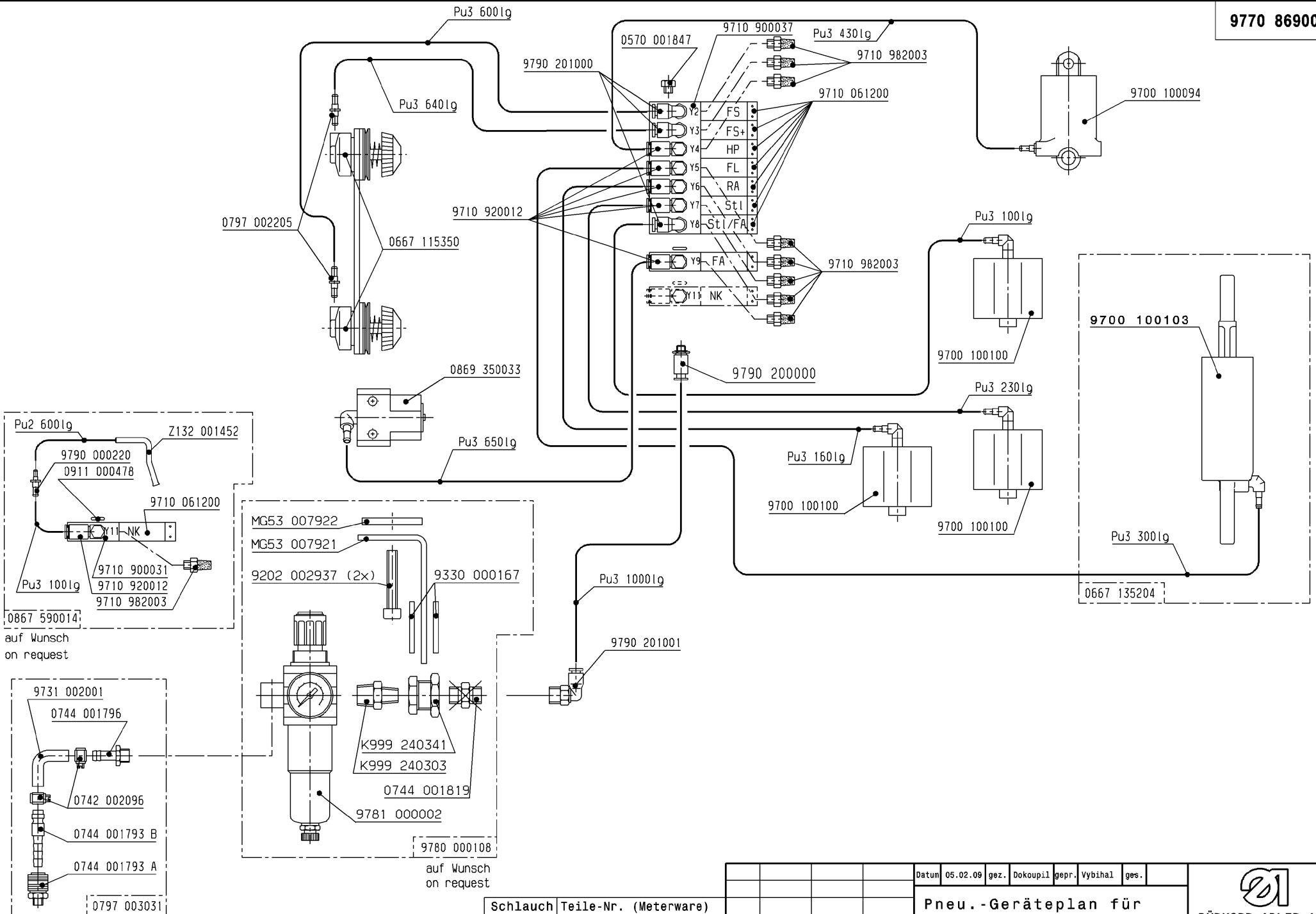

auf Wunsch
on request

auf Wunsch
on request

auf Wunsch
on request

Schlauch Hose	Teile-Nr. (Meterware) Part-No. (Yarded goods)
PU2	0699 979265
PU3	9731 005004

Datum	05.02.09	gez.	Dokoupil	gepr.	Vybihal	ges.
Pneu.-Geräteplan für Pneu.-Elements-Plan for 0869-180322 und 0869-280322						
Änd.	Datum	gez.	gepr.			

DÜRKOPP ADLER AG
9770 869001
 Blatt 2 Blattz. 2